

- NOTES: VALID UNLESS OTHERWISE SPECIFIED
1. GENERAL:
 - a. CONNECTOR HEADER MUST BE VALIDATED TO THE FOLLOWING FUNCTIONAL REQUIREMENTS:
 - POLARIZATION FEATURE EFFECTIVENESS - SEE PRODUCT SPECIFICATION
 - PIN RETENTION - USCAR-2 REV 4
 - SOLDERABILITY - SMES-152
 - b. APPLICATION REQUIREMENTS (REFERENCE ONLY) FOR:
 - SEE APPLICATION SPECIFICATION - AS-34729-020/AS-31408-100
 - SEE PRODUCT SPECIFICATION - PS-34729-020/PS-34729-020
 - c. PACKAGING SPECIFICATION: SEE CHART
 2. DESIGN: MATERIALS:
 - a. SHROUD (PLASTIC HOUSING):
 - RESIN - SPS 30%GF - 20% REGRIND MAX. BY WEIGHT
 - b. 0.64MM PINS:
 - BASE MATERIAL: C26000
 - PLATING TYPE: AS NOTED
 - c. PIN ALIGNMENT PLATE: RESIN - SPS 30%GF - 20% REGRIND MAX. BY WEIGHT
 3. PLATING REQUIREMENTS:
 - a. UNDERPLATING - OVERALL NICKEL
 - b. OVERPLATING - OVERALL TIN
 4. INTERFACE: USCAR
 - 064-U-008-2-202
 - 064-U-012-2-203
 - 064-U-016-2-203
 - 064-U-020-2-202

SOME CHAMFERS HAVE BEEN MODIFIED TO IMPROVE POLARIZATION EFFECTIVENESS. SEE AS-34729-002/AS-31408-100.

REMOVE PANEL VIEW DEC NO: UAU2007-1044 DRAWN: FISCHER01 2017/05/11 CHKD: APPR: RBAUMAN 2017/05/15	QUALITY SYMBOLS	GENERAL TOLERANCES (UNLESS SPECIFIED)	DIMENSION STYLE	SCALE	DESIGN UNITS	THIRD ANGLE PROJECTION															
	$\nabla=0$ $\nabla=0$	<table border="1"> <thead> <tr> <th></th> <th>mm</th> <th>INCH</th> </tr> </thead> <tbody> <tr> <td>4 PLACES</td> <td>±.005</td> <td>±.0002</td> </tr> <tr> <td>3 PLACES</td> <td>±.008</td> <td>±.0003</td> </tr> <tr> <td>2 PLACES</td> <td>±.013</td> <td>±.0005</td> </tr> <tr> <td>1 PLACE</td> <td>±.025</td> <td>±.0010</td> </tr> </tbody> </table>		mm	INCH	4 PLACES	±.005	±.0002	3 PLACES	±.008	±.0003	2 PLACES	±.013	±.0005	1 PLACE	±.025	±.0010	MM ONLY	2:1	METRIC	
		mm	INCH																		
	4 PLACES	±.005	±.0002																		
3 PLACES	±.008	±.0003																			
2 PLACES	±.013	±.0005																			
1 PLACE	±.025	±.0010																			
		DRAWN BY: JFISCHER01 DATE: 2013/07/26 CHECKED BY: _____ DATE: _____	TITLE: STAC64 PAP R/A LONG PIN																		
		APPROVED BY: RBAUMAN DATE: 2013/08/05	MOLEX INCORPORATED DOCUMENT NO. SD-34691-601 SHEET NO. 1 OF 3																		

DRAFT WHERE APPLICABLE MUST REMAIN WITHIN DIMENSIONS

SIZE D THIS DRAWING CONTAINS INFORMATION THAT IS PROPRIETARY TO MOLEX INCORPORATED AND SHOULD NOT BE USED WITHOUT WRITTEN PERMISSION

MATERIAL NUMBER		CKT SIZE	DESCRIPTION	POL	COLOR	MATERIAL NUMBER		CKT SIZE	DESCRIPTION	POL	COLOR
TRAY PACKAGING PK-31300-892	TUBE PACKAGING PK-31301-063					TRAY PACKAGING PK-31300-892	TUBE PACKAGING PK-31301-063				
34691-6200	34691-9246	20	STAC64 RIGHT ANGLE HEADER ASSEMBLY	A	BLACK	34691-6120	34691-9623	12	STAC64 RIGHT ANGLE HEADER ASSEMBLY	A	BLACK
34691-6201	34691-9256	20	STAC64 RIGHT ANGLE HEADER ASSEMBLY	B	GREY	34691-6121	34691-9624	12	STAC64 RIGHT ANGLE HEADER ASSEMBLY	B	GREY
34691-6202	34691-9266	20	STAC64 RIGHT ANGLE HEADER ASSEMBLY	C	BROWN	34691-6122	34691-9625	12	STAC64 RIGHT ANGLE HEADER ASSEMBLY	C	BROWN
34691-6203	34691-9276	20	STAC64 RIGHT ANGLE HEADER ASSEMBLY	D	GREEN	34691-6080	34691-9680	8	STAC64 RIGHT ANGLE HEADER ASSEMBLY	A	BLACK
34691-6160	34691-9660	16	STAC64 RIGHT ANGLE HEADER ASSEMBLY	A	BLACK	34691-6081	34691-9681	8	STAC64 RIGHT ANGLE HEADER ASSEMBLY	B	GREY
34691-6161	34691-9661	16	STAC64 RIGHT ANGLE HEADER ASSEMBLY	B	GREY	34691-6082	34691-9682	8	STAC64 RIGHT ANGLE HEADER ASSEMBLY	C	BROWN
34691-6162	34691-9662	16	STAC64 RIGHT ANGLE HEADER ASSEMBLY	C	BROWN						

REMOVE PANEL VIEW EEC NO. UAU2017-1044 DRAWN: JFISCHERO1 2017/05/11 CHKD: [Signature] APPR: RBAUMAN 2017/05/15 REV: [Signature]	QUALITY SYMBOLS ▽=0 ▽=0	GENERAL TOLERANCES (UNLESS SPECIFIED) mm INCH 4 PLACES ± --- ± --- 3 PLACES ± --- ± --- 2 PLACES ± 0.13 ± --- 1 PLACE ± 0.25 ± --- ANGULAR ± 1°	DIMENSION STYLE MM ONLY DRAWN BY DATE JFISCHERO1 2013/07/26 CHECKED BY DATE [Signature]	SCALE 4:1 DESIGN UNITS METRIC THIRD ANGLE PROJECTION	TITLE STAC64 PAP R/A LONG PIN
	DRAFT WHERE APPLICABLE MUST REMAIN WITHIN DIMENSIONS		APPROVED BY DATE RBAUMAN 2013/08/05	MATERIAL NO. SEE CHART	DOCUMENT NO. SD-34691-601
	THIS DRAWING CONTAINS INFORMATION THAT IS PROPRIETARY TO MOLEX INCORPORATED AND SHOULD NOT BE USED WITHOUT WRITTEN PERMISSION				
				SHEET NO. 2 OF 3	

CKT SIZE	DIM 'A'	DIM 'B'	DIM 'C'	DIM 'D'
20	34.04	31.57	27.94	25.54
16	28.96	26.49	22.86	20.46
12	23.88	21.41	17.78	15.38
8	18.80	16.53	12.70	10.30

RECOMMENDED PCB LAYOUT

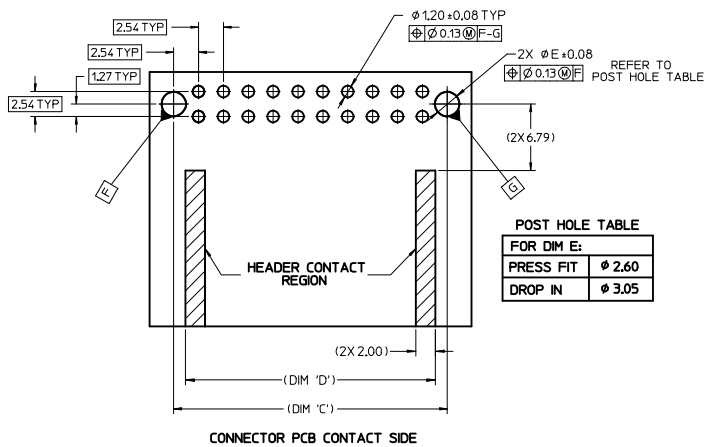

POST HOLE TABLE	
FOR DIM E:	
PRESS FIT	Ø 2.60
DROP IN	Ø 3.05

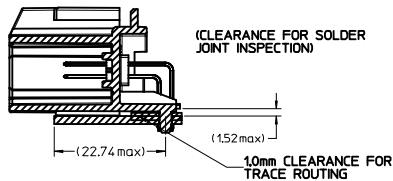

RECOMMENDED FOR REFLOW SOLDER
 FLUSH MOUNTING:
 SCALE 2:1

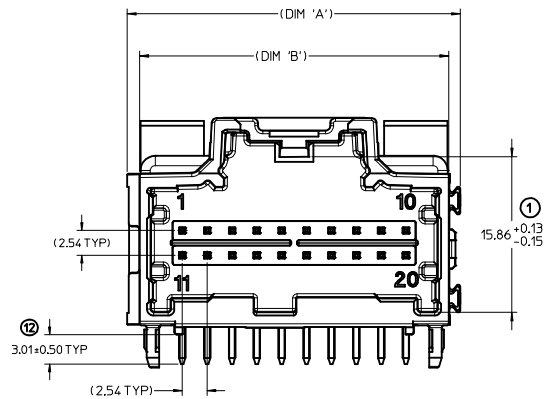

LAYOUT FOR 16 & 20 CKT. HEADERS
 (20 CKT. OPTION 'A' SHOWN)

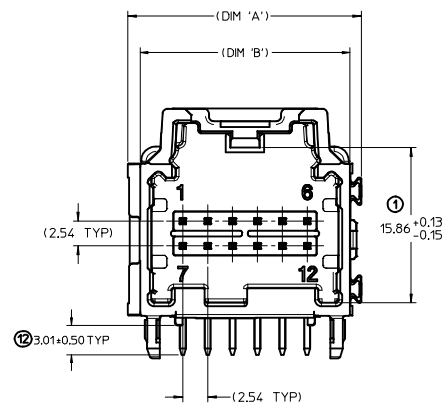

LAYOUT FOR 8 & 12 CKT. HEADERS
 (12 CKT. OPTION 'A' SHOWN)

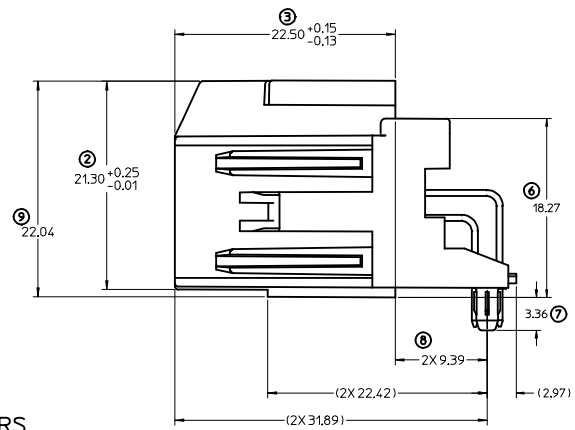
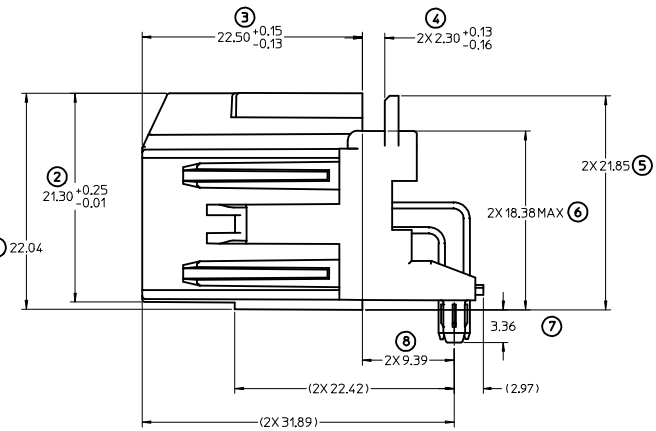

ENTER DESCRIPTION IEC NO. UAU2017-1044 DRAWN BY JFISCHER01 2013/07/11 CHKD: RBAUMAN APPR: RBAUMAN 2013/08/05	QUALITY SYMBOLS ∇=0 ∇=0 ∇=0	GENERAL TOLERANCES (UNLESS SPECIFIED)		DIMENSION STYLE MM ONLY	SCALE 4:1	DESIGN UNITS METRIC	THIRD ANGLE PROJECTION	
		4 PLACES ± mm ± INCH	3 PLACES ± --- ± ---	DRAWN BY DATE JFISCHER01 2013/07/26	TITLE STAC64 PAP R/A LONG PIN			
		2 PLACES ± 0.13 ± ---	1 PLACE ± 0.25 ± ---	CHECKED BY DATE RBAUMAN 2013/08/05	MATERIAL NO. SEE CHART			
		0 PLACE ± --- ± ---	ANGULAR ± 1 °	APPROVED BY RBAUMAN	DOCUMENT NO. SD-34691-601	SHEET NO. 3 OF 3		

THIS DRAWING CONTAINS INFORMATION THAT IS PROPRIETARY TO MOLEX INCORPORATED AND SHOULD NOT BE USED WITHOUT WRITTEN PERMISSION

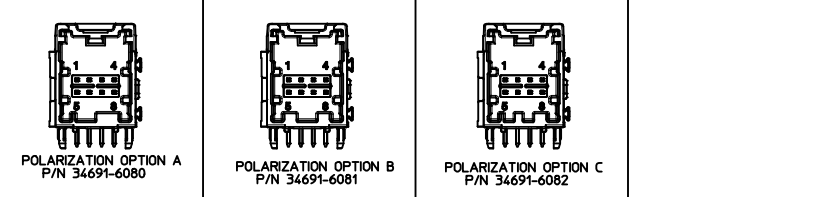
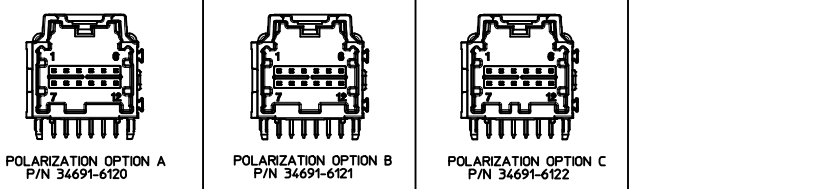
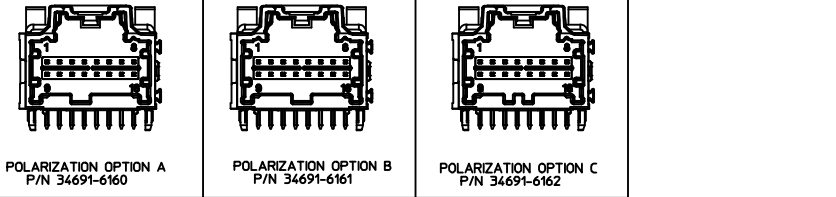
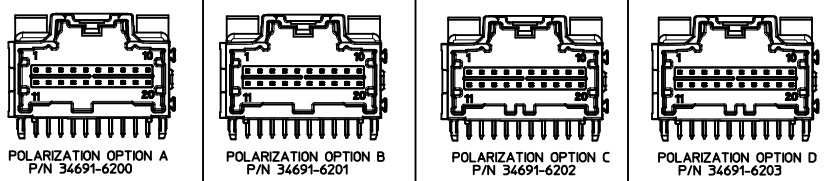

- NOTES: VALID UNLESS OTHERWISE SPECIFIED
1. GENERAL:
 - a. CONNECTOR HEADER MUST BE VALIDATED TO THE FOLLOWING FUNCTIONAL REQUIREMENTS:
 - POLARIZATION FEATURE EFFECTIVENESS - SEE PRODUCT SPECIFICATION
 - PIN RETENTION - USCAR-2 REV 4
 - SOLDERABILITY - SMES-152
 - b. APPLICATION REQUIREMENTS (REFERENCE ONLY) FOR:
 - SEE APPLICATION SPECIFICATION - AS-34729-020/AS-31408-100
 - SEE PRODUCT SPECIFICATION - PS-34729-020/PS-34729-020
 - c. PACKAGING SPECIFICATION: SEE CHART
 2. DESIGN: MATERIALS:
 - a. SHROUD (PLASTIC HOUSING):
 - RESIN - SPS 30%GF - 20% REGRIND MAX. BY WEIGHT
 - b. 0.64MM PINS:
 - BASE MATERIAL: C26000
 - PLATING TYPE: AS NOTED
 - c. PIN ALIGNMENT PLATE: RESIN - SPS 30%GF - 20% REGRIND MAX. BY WEIGHT
 3. PLATING REQUIREMENTS:
 - a. UNDERPLATING - OVERALL NICKEL
 - b. OVERPLATING - OVERALL TIN
 4. INTERFACE: USCAR
 - 064-U-008-2-202
 - 064-U-012-2-203
 - 064-U-016-2-203
 - 064-U-020-2-202

SOME CHAMFERS HAVE BEEN MODIFIED TO IMPROVE POLARIZATION EFFECTIVENESS. SEE AS-34729-002/AS-31408-100.

REMOVE PANEL VIEW DEC NO: UAU2007-1044 DRAWN: FISCHER01 2017/05/11 CHKD: APPR: RBAUMAN 2017/05/15	QUALITY SYMBOLS	GENERAL TOLERANCES (UNLESS SPECIFIED)	DIMENSION STYLE	SCALE	DESIGN UNITS	THIRD ANGLE PROJECTION														
	$\nabla=0$ $\nabla=0$	<table border="1"> <thead> <tr> <th></th> <th>mm</th> <th>INCH</th> </tr> </thead> <tbody> <tr> <td>4 PLACES</td> <td>±.005</td> <td>±.0004</td> </tr> <tr> <td>3 PLACES</td> <td>±.008</td> <td>±.0003</td> </tr> <tr> <td>2 PLACES</td> <td>±.013</td> <td>±.0005</td> </tr> <tr> <td>1 PLACE</td> <td>±.025</td> <td>±.0010</td> </tr> </tbody> </table> ANGULAR ± 1°		mm	INCH	4 PLACES	±.005	±.0004	3 PLACES	±.008	±.0003	2 PLACES	±.013	±.0005	1 PLACE	±.025	±.0010	MM ONLY DRAWN BY: JFISCHER01 DATE: 2013/07/26 CHECKED BY:	2:1 METRIC	TITLE: STAC64 PAP R/A LONG PIN
		mm	INCH																	
	4 PLACES	±.005	±.0004																	
3 PLACES	±.008	±.0003																		
2 PLACES	±.013	±.0005																		
1 PLACE	±.025	±.0010																		
DRAFT WHERE APPLICABLE MUST REMAIN WITHIN DIMENSIONS	APPROVED BY: RBAUMAN DATE: 2013/08/05	MATERIAL NO. SEE CHART DOCUMENT NO. SD-34691-601	MOLEX INCORPORATED	SHEET NO. 1 OF 3																
THIS DRAWING CONTAINS INFORMATION THAT IS PROPRIETARY TO MOLEX INCORPORATED AND SHOULD NOT BE USED WITHOUT WRITTEN PERMISSION																				

MATERIAL NUMBER		CKT SIZE	DESCRIPTION	POL	COLOR	MATERIAL NUMBER		CKT SIZE	DESCRIPTION	POL	COLOR
TRAY PACKAGING PK-31300-892	TUBE PACKAGING PK-31301-063					TRAY PACKAGING PK-31300-892	TUBE PACKAGING PK-31301-063				
34691-6200	34691-9246	20	STAC64 RIGHT ANGLE HEADER ASSEMBLY	A	BLACK	34691-6120	34691-9623	12	STAC64 RIGHT ANGLE HEADER ASSEMBLY	A	BLACK
34691-6201	34691-9256	20	STAC64 RIGHT ANGLE HEADER ASSEMBLY	B	GREY	34691-6121	34691-9624	12	STAC64 RIGHT ANGLE HEADER ASSEMBLY	B	GREY
34691-6202	34691-9266	20	STAC64 RIGHT ANGLE HEADER ASSEMBLY	C	BROWN	34691-6122	34691-9625	12	STAC64 RIGHT ANGLE HEADER ASSEMBLY	C	BROWN
34691-6203	34691-9276	20	STAC64 RIGHT ANGLE HEADER ASSEMBLY	D	GREEN	34691-6080	34691-9680	8	STAC64 RIGHT ANGLE HEADER ASSEMBLY	A	BLACK
34691-6160	34691-9660	16	STAC64 RIGHT ANGLE HEADER ASSEMBLY	A	BLACK	34691-6081	34691-9681	8	STAC64 RIGHT ANGLE HEADER ASSEMBLY	B	GREY
34691-6161	34691-9661	16	STAC64 RIGHT ANGLE HEADER ASSEMBLY	B	GREY	34691-6082	34691-9682	8	STAC64 RIGHT ANGLE HEADER ASSEMBLY	C	BROWN
34691-6162	34691-9662	16	STAC64 RIGHT ANGLE HEADER ASSEMBLY	C	BROWN						

REMOVE PANEL VIEW EEC NO. UAU2017-1044 DRAWN: JFISCHERO1 2017/05/11 CHKD: [Signature] APPR: RBAUMAN 2017/05/15 REV: [Signature]	QUALITY SYMBOLS =0 =0	GENERAL TOLERANCES (UNLESS SPECIFIED) mm INCH 4 PLACES ± --- ± --- 3 PLACES ± --- ± --- 2 PLACES ± 0.13 ± --- 1 PLACE ± 0.25 ± --- ANGULAR ± 1°	DIMENSION STYLE MM ONLY DRAWN BY DATE JFISCHERO1 2013/07/26 CHECKED BY DATE [Signature]	SCALE 4:1 DESIGN UNITS METRIC THIRD ANGLE PROJECTION	TITLE STAC64 PAP R/A LONG PIN	
	DRAFT WHERE APPLICABLE MUST REMAIN WITHIN DIMENSIONS		APPROVED BY DATE RBAUMAN 2013/08/05	MATERIAL NO. SEE CHART	DOCUMENT NO. SD-34691-601	
			MOLEX INCORPORATED	SHEET NO. 2 OF 3		
	THIS DRAWING CONTAINS INFORMATION THAT IS PROPRIETARY TO MOLEX INCORPORATED AND SHOULD NOT BE USED WITHOUT WRITTEN PERMISSION					

CKT SIZE	DIM 'A'	DIM 'B'	DIM 'C'	DIM 'D'
20	34.04	31.57	27.94	25.54
16	28.96	26.49	22.86	20.46
12	23.88	21.41	17.78	15.38
8	18.80	16.53	12.70	10.30

RECOMMENDED PCB LAYOUT

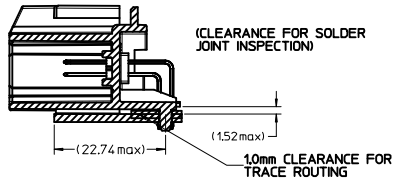
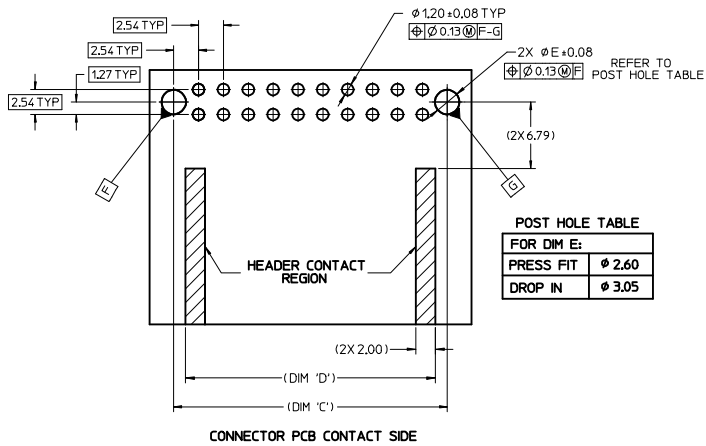

RECOMMENDED FOR REFLOW SOLDER
 FLUSH MOUNTING:
 SCALE 2:1

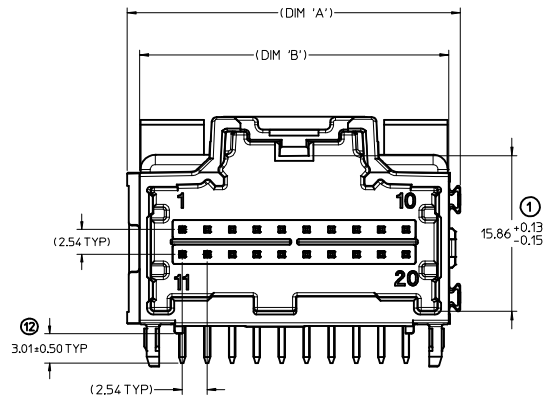

LAYOUT FOR 16 & 20 CKT. HEADERS
 (20 CKT. OPTION 'A' SHOWN)

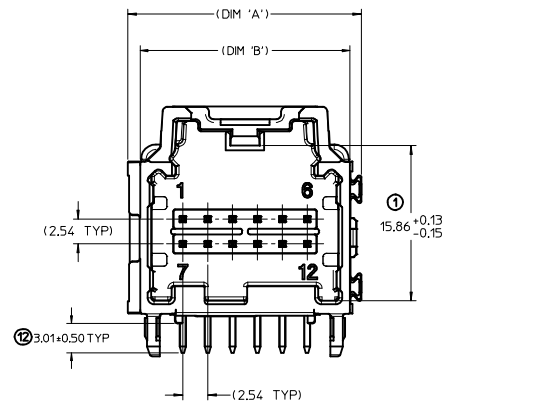

LAYOUT FOR 8 & 12 CKT. HEADERS
 (12 CKT. OPTION 'A' SHOWN)

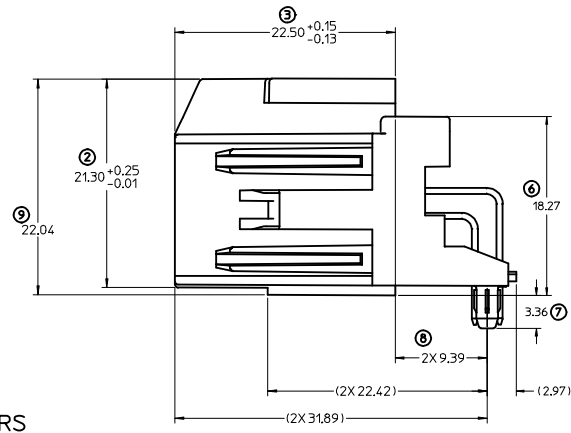
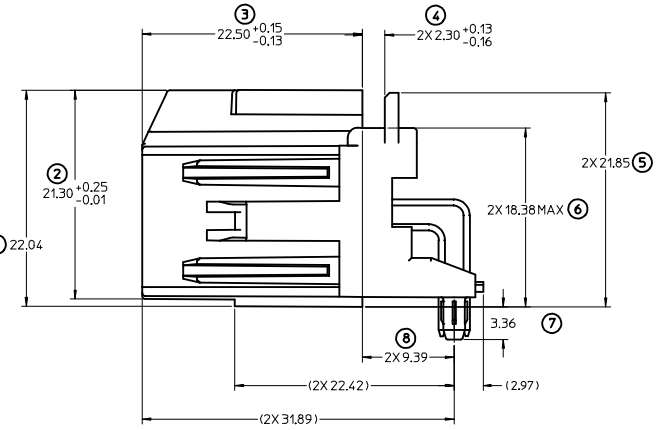

ENTER DESCRIPTION IEC NO. UAU2017-1044 DRAWN BY JFISCHER01 2017/05/11 CHKD: RBAUMAN APPR: RBAUMAN 2017/05/15	QUALITY SYMBOLS ▽=0 ▽=0 ▽=0	GENERAL TOLERANCES (UNLESS SPECIFIED)		DIMENSION STYLE	SCALE	DESIGN UNITS	THIRD ANGLE PROJECTION
		mm	INCH	MM ONLY	4:1	METRIC	☉
		4 PLACES	± ---	± ---			
		3 PLACES	± ---	± ---			
		2 PLACES	± 0.13	± ---			
		1 PLACE	± 0.25	± ---			
		0 PLACE	± ---	± ---			
		ANGULAR ± 1°					
DRAFT WHERE APPLICABLE MUST REMAIN WITHIN DIMENSIONS		MATERIAL NO.		DRAWN BY DATE		TITLE	
		SEE CHART		JFISCHER01 2013/07/26		STAC64 PAP R/A LONG PIN	
				CHECKED BY DATE			
				APPROVED BY DATE			
				RBAUMAN 2013/08/05			
				DOCUMENT NO.		SHEET NO.	
				SD-34691-601		3 OF 3	
THIS DRAWING CONTAINS INFORMATION THAT IS PROPRIETARY TO MOLEX INCORPORATED AND SHOULD NOT BE USED WITHOUT WRITTEN PERMISSION							