

MX150 DUAL ROW RIGHT ANGLE HEADER

1.0 SCOPE: This manual contains supplemental information pertaining to the Molex MX150 Dual Row, Right Angle Header product line, Molex series numbers 34829 and 34830

2.0 PRODUCT DESCRIPTION: The MX150 Dual Row, Right Angle Header product line is a series of Printed Circuit Board (PCB) mounted headers with the following pin configurations: 2x2, 2x3, 2x4, 2x6, 2x8, and 2x10. It features either through hole solder or press fit compliant pins for the PCB interface. It is designed to mate with the Molex MX150 connector family, series number 33472, see reference document list for applicable specifications.

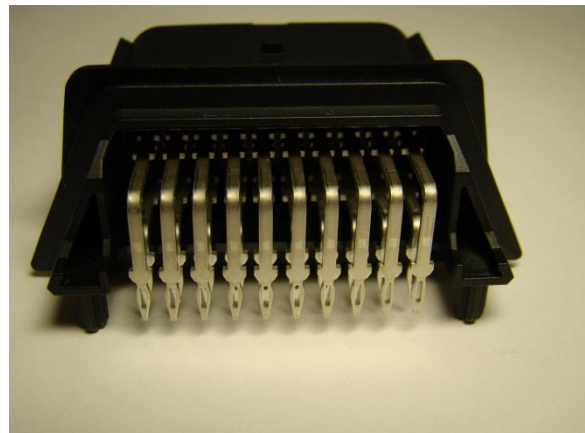

3.0 REFERENCE DOCUMENTS:

- | | |
|--------------|---------------------------------|
| SD-34829-001 | Sales Drawing |
| PK-34830-001 | Packaging Specification |
| SD-31503-012 | Compliant Pin Specification |
| AS-33472-100 | MX150 Application Specification |
| PS-33472-000 | MX150 Product Specification |

REVISION: A	ECR/ECN INFORMATION: <u>EC No:</u> UAU2013-1201 <u>DATE:</u> 2013/01/29	TITLE: <b style="text-align: center;">Application Specification MX150 Dual Row Right Angle Header	SHEET No. 1 of 12
DOCUMENT NUMBER: AS-34829-001		CREATED / REVISED BY: Tim Skiver	CHECKED BY: Chris Taylor
		APPROVED BY: Paul Berg	

MX150 DUAL ROW RIGHT ANGLE HEADER

Casting Interface (reference only)

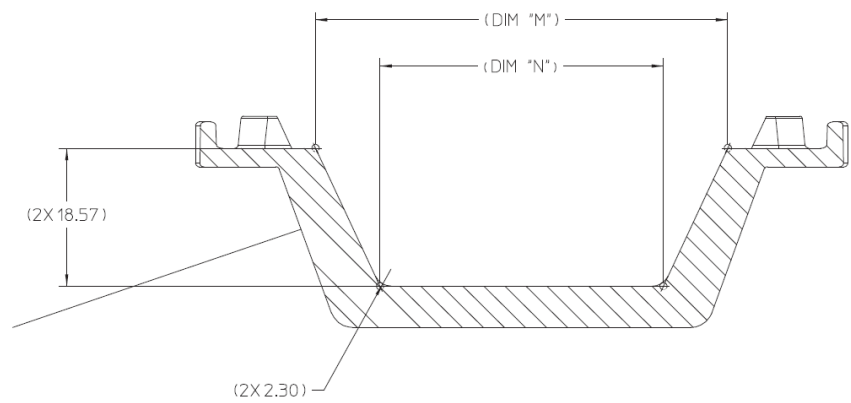
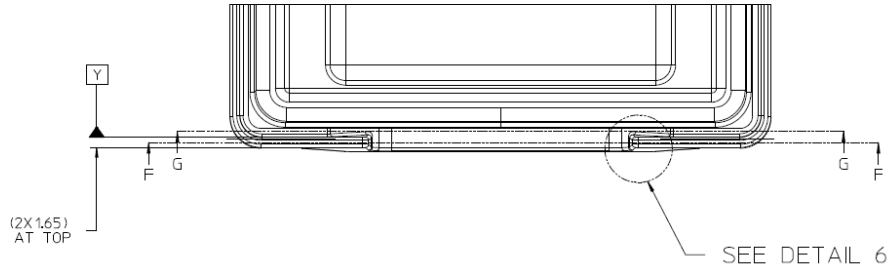

SECTION G-G
SCALE 2:1

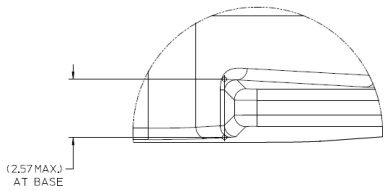

DETAIL 6
SCALE 10:1

DESCRIPTION	DIMENSIONS			
	M	N	P	Q
2X2 HEADER	27.48	10.16	13.89	10.16
2X3 HEADER	30.98	13.66	17.39	13.66
2X4 HEADER	34.48	17.16	20.89	17.16
2X6 HEADER	41.48	24.16	27.89	24.16
2X8 HEADER	48.48	31.16	34.89	31.16
2X10 HEADER	55.48	38.16	41.89	38.16

REVISION:	ECR/ECN INFORMATION:	TITLE:		SHEET No.
A	EC No: UAU2013-1201 DATE: 2013/01/29	Application Specification MX150 Dual Row Right Angle Header		2 of 12
DOCUMENT NUMBER:		CREATED / REVISED BY:	CHECKED BY:	APPROVED BY:
AS-34829-001		Tim Skiver	Chris Taylor	Paul Berg

MX150 DUAL ROW RIGHT ANGLE HEADER

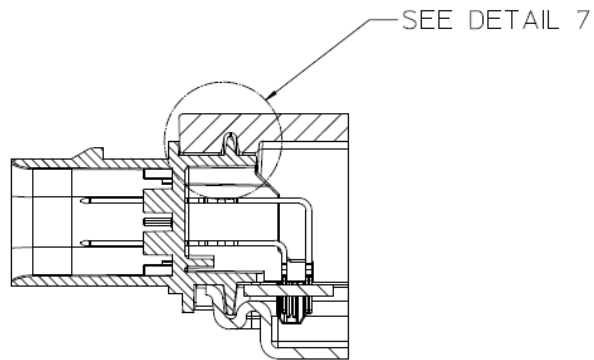
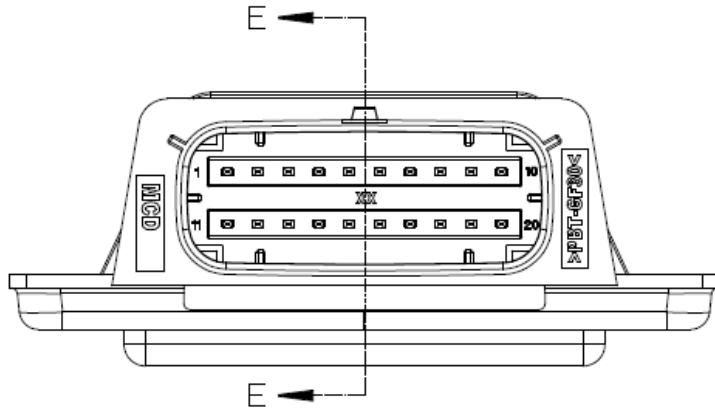
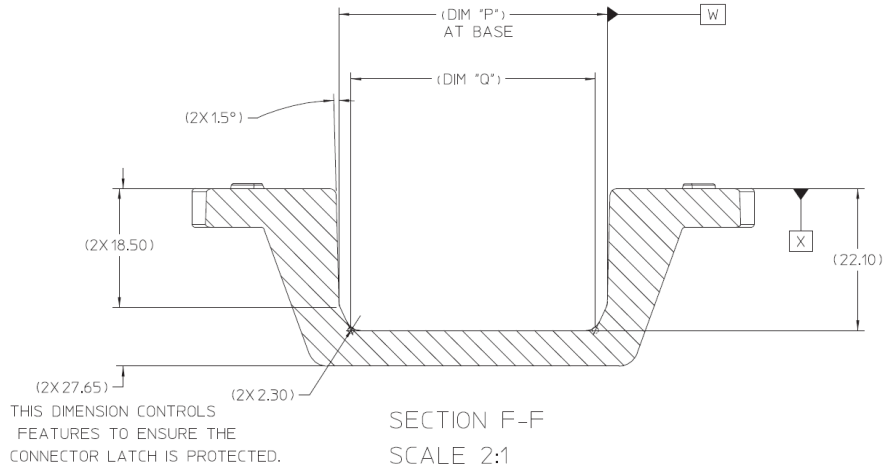

REVISION: A	ECR/ECN INFORMATION: EC No: UAU2013-1201 DATE: 2013/01/29	TITLE: Application Specification MX150 Dual Row Right Angle Header	SHEET No. 3 of 12
DOCUMENT NUMBER: AS-34829-001	CREATED / REVISED BY: Tim Skiver	CHECKED BY: Chris Taylor	APPROVED BY: Paul Berg

MX150 DUAL ROW RIGHT ANGLE HEADER

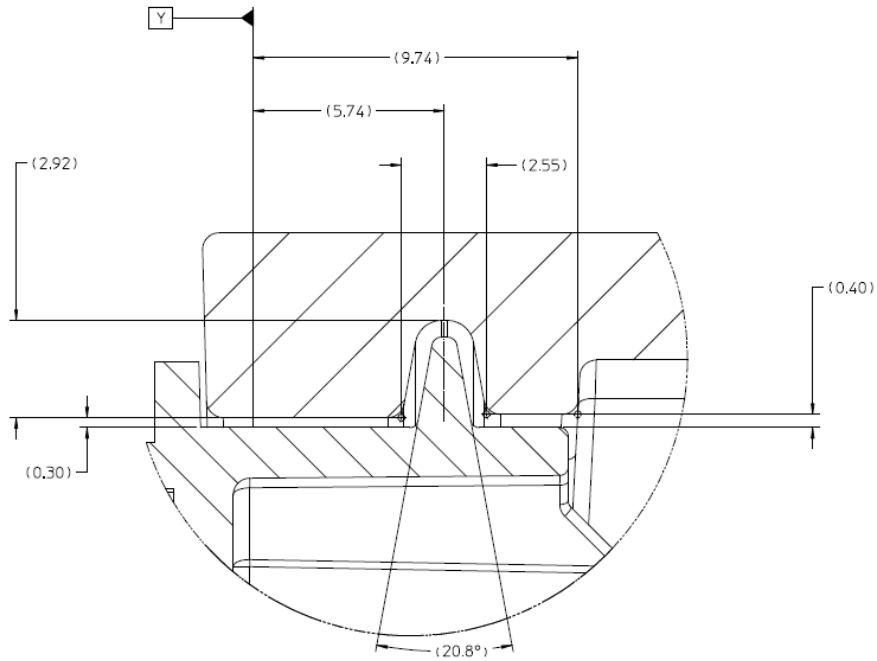

TYPICAL CONSTRUCTION
DETAIL 7

Recommended Header to Casting Adhesive

Dow Corning® 7091 Adhesive/Sealant

Please consult Dow Corning® for curing recommendations

www.dowcorning.com

REVISION:	ECR/ECN INFORMATION:	TITLE:		SHEET No.
A	EC No: UAU2013-1201 DATE: 2013/01/29	Application Specification MX150 Dual Row Right Angle Header		4 of 12
DOCUMENT NUMBER:		CREATED / REVISED BY:	CHECKED BY:	APPROVED BY:
AS-34829-001		Tim Skiver	Chris Taylor	Paul Berg

MX150 DUAL ROW RIGHT ANGLE HEADER

Recommended PCB Layout (reference only)

Compliant Pin PCB Interface

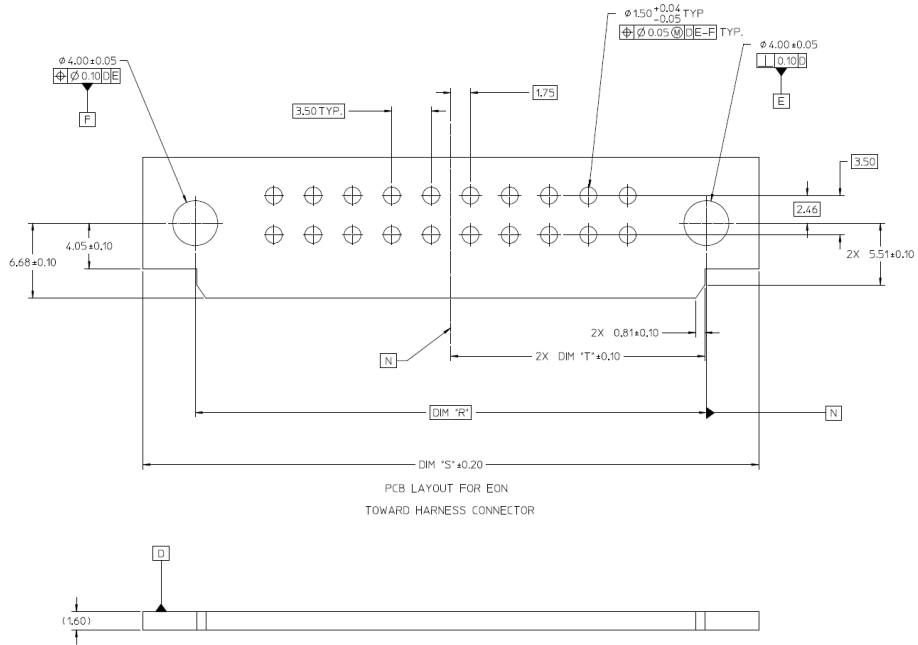

Solder Pin Interface

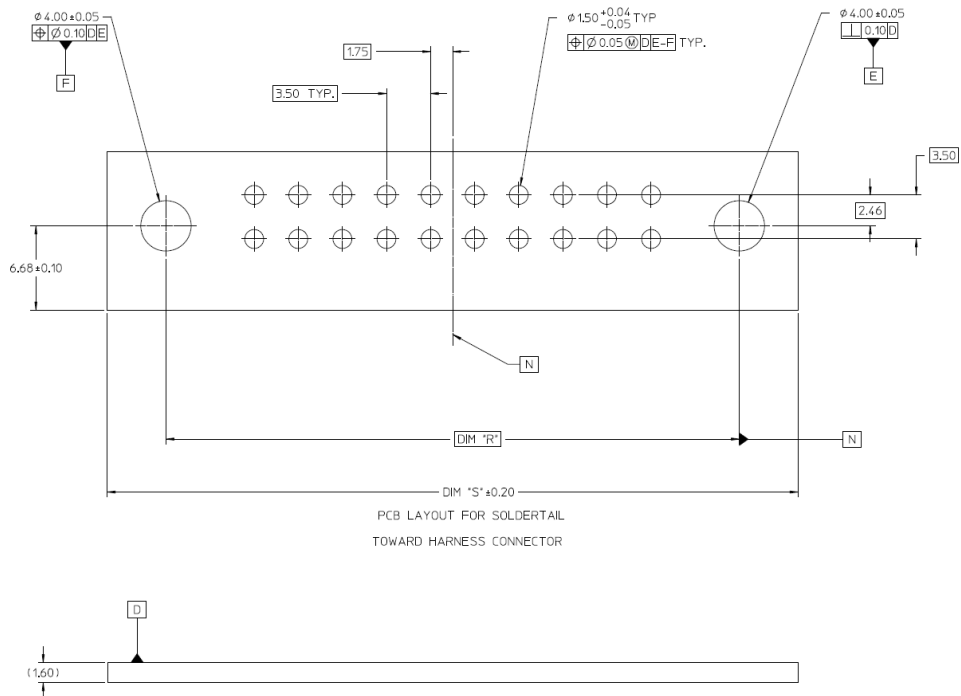

REVISION: A	ECR/ECN INFORMATION: EC No: UAU2013-1201 DATE: 2013/01/29	TITLE: Application Specification MX150 Dual Row Right Angle Header	SHEET No. 5 of 12
DOCUMENT NUMBER: AS-34829-001	CREATED / REVISED BY: Tim Skiver	CHECKED BY: Chris Taylor	APPROVED BY: Paul Berg



MX150 DUAL ROW RIGHT ANGLE HEADER

DESCRIPTION	DIMENSIONS		
	R	S	T
2X2 HEADER	17.50	26.82	8.61
2X3 HEADER	21.00	30.32	10.36
2X4 HEADER	24.50	33.82	12.11
2X6 HEADER	31.50	40.82	15.61
2X8 HEADER	38.50	47.82	19.11
2X10 HEADER	45.50	54.82	22.61

Please refer to SD-31503-012 for PCB plating requirements

REVISION: A	ECR/ECN INFORMATION: EC No: UAU2013-1201 DATE: 2013/01/29	TITLE: Application Specification MX150 Dual Row Right Angle Header	SHEET No. 6 of 12
DOCUMENT NUMBER: AS-34829-001	CREATED / REVISED BY: Tim Skiver	CHECKED BY: Chris Taylor	APPROVED BY: Paul Berg

MX150 DUAL ROW RIGHT ANGLE HEADER

4.0 PROCEDURE

4.1 ASSEMBLY INSTRUCTIONS:

Please ensure that care is taken to avoid damaging the terminals or the plastic during the assembly process

A. PCB INSERTION

- i. Solder pins – Insert alignment posts into PCB and press as shown until seated

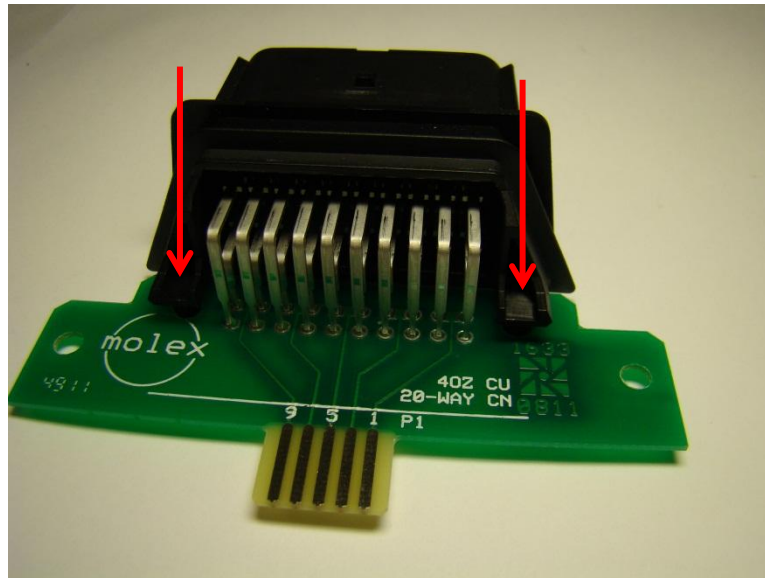

REVISION: A	ECR/ECN INFORMATION: EC No: UAU2013-1201 DATE: 2013/01/29	TITLE: Application Specification MX150 Dual Row Right Angle Header	SHEET No. 7 of 12
DOCUMENT NUMBER: AS-34829-001		CREATED / REVISED BY: Tim Skiver	CHECKED BY: Chris Taylor
		APPROVED BY: Paul Berg	

MX150 DUAL ROW RIGHT ANGLE HEADER

- ii. Compliant pins – Insert alignment posts into PCB and press as shown to depth as specified in SD-31503-012. **NOTE: Force must be applied to all compliant pins as shown in the detail view.**

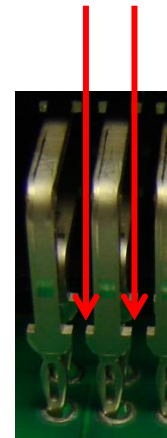
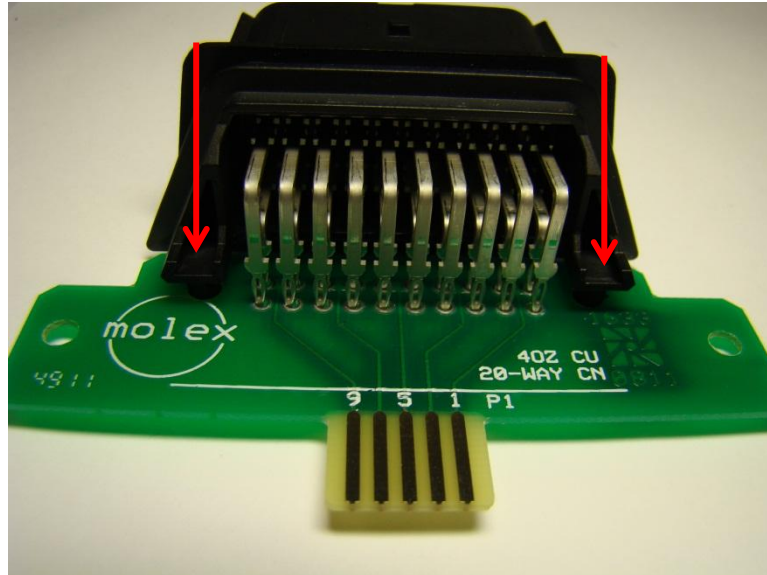

REVISION: A	ECR/ECN INFORMATION: EC No: UAU2013-1201 DATE: 2013/01/29	TITLE: Application Specification MX150 Dual Row Right Angle Header	SHEET No. 8 of 12
DOCUMENT NUMBER: AS-34829-001	CREATED / REVISED BY: Tim Skiver	CHECKED BY: Chris Taylor	APPROVED BY: Paul Berg

MX150 DUAL ROW RIGHT ANGLE HEADER

**B. CONNECTOR MATING:
FOR ADDITIONAL INFORMATION PLEASE REFER TO THE MX150 CONNECTOR
APPLICATION SPECIFICATION, AS-33472-100**

Slide the connector and header together, press firmly until you hear an audible click

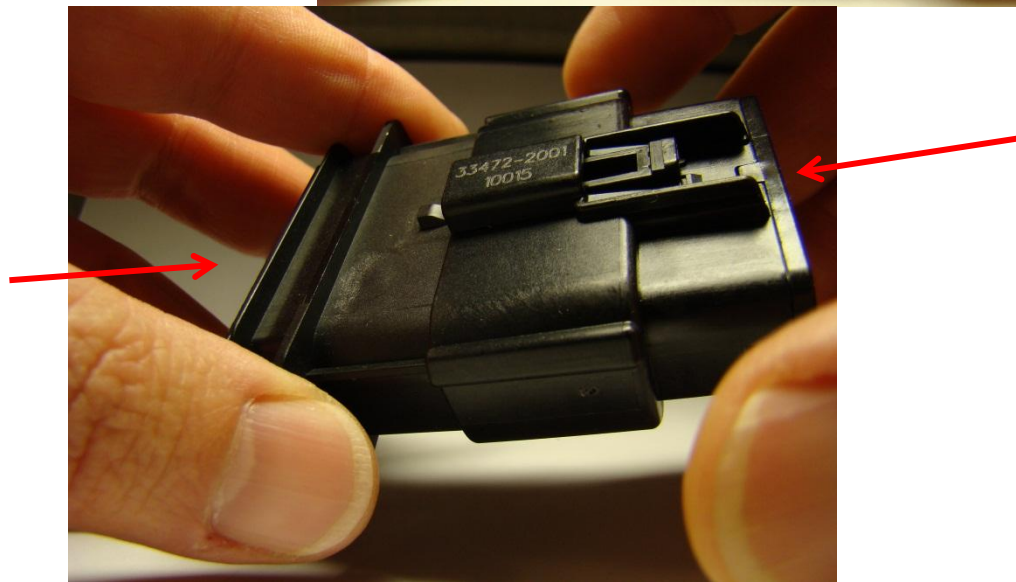
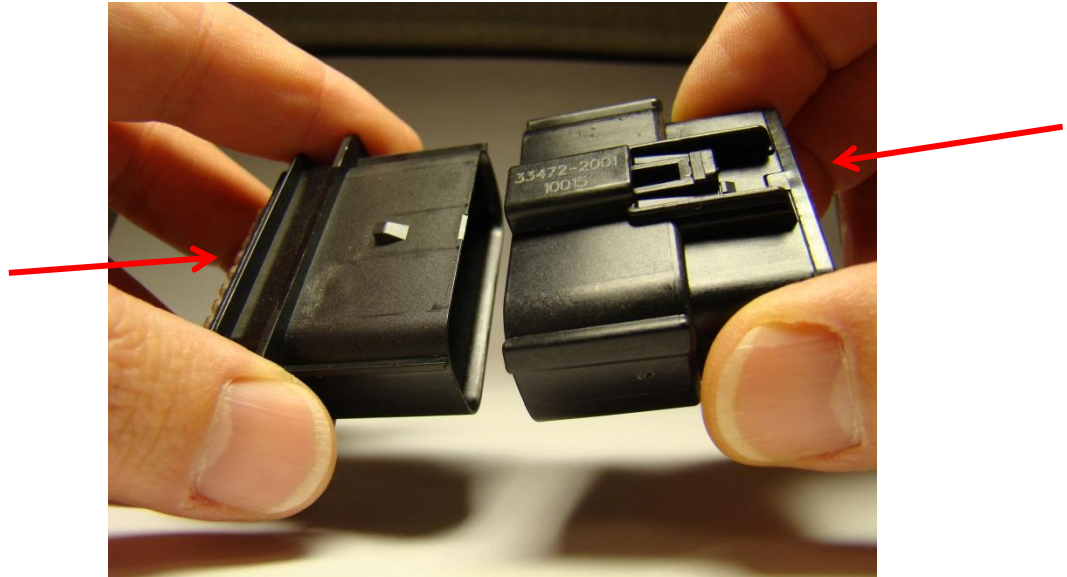

REVISION: A	ECR/ECN INFORMATION: EC No: UAU2013-1201 DATE: 2013/01/29	TITLE: Application Specification MX150 Dual Row Right Angle Header	SHEET No. 9 of 12
DOCUMENT NUMBER: AS-34829-001	CREATED / REVISED BY: Tim Skiver	CHECKED BY: Chris Taylor	APPROVED BY: Paul Berg

MX150 DUAL ROW RIGHT ANGLE HEADER

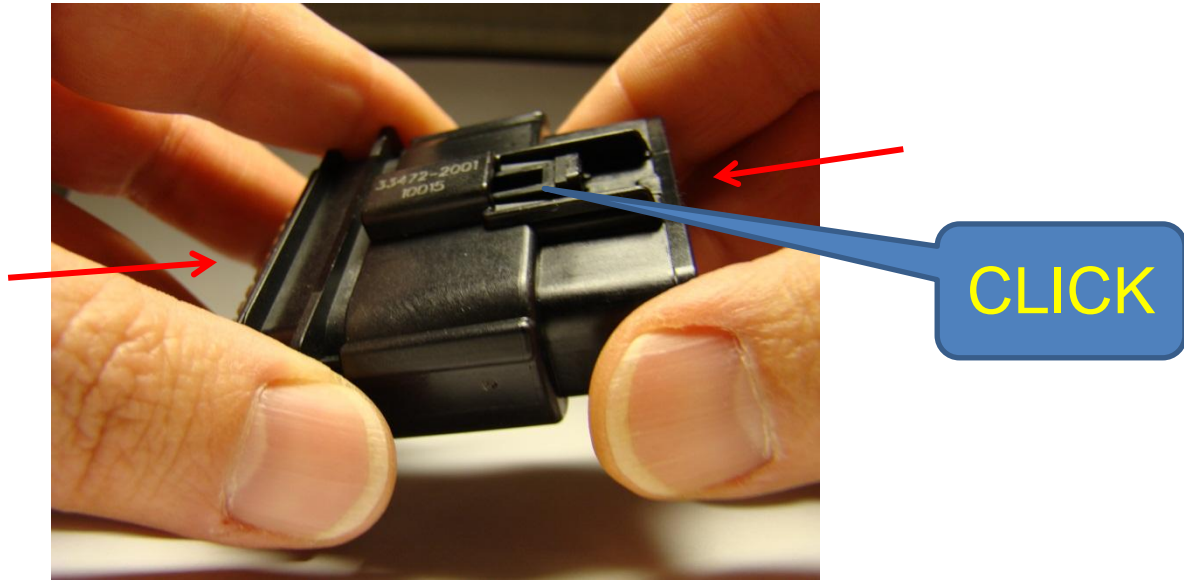

REVISION: A	ECR/ECN INFORMATION: EC No: UAU2013-1201 DATE: 2013/01/29	TITLE: Application Specification MX150 Dual Row Right Angle Header	SHEET No. 10 of 12
DOCUMENT NUMBER: AS-34829-001	CREATED / REVISED BY: Tim Skiver	CHECKED BY: Chris Taylor	APPROVED BY: Paul Berg

TEMPLATE FILENAME: APPLICATION_SPEC[SIZE_A](V.1).DOC

MX150 DUAL ROW RIGHT ANGLE HEADER

4.2 REMOVAL INSTRUCTIONS

A. CONNECTOR UNMATING:

Push the connector halves together to unload the pressure on the latch system



Depress the latch and hold it down while gently pulling the connector halves apart

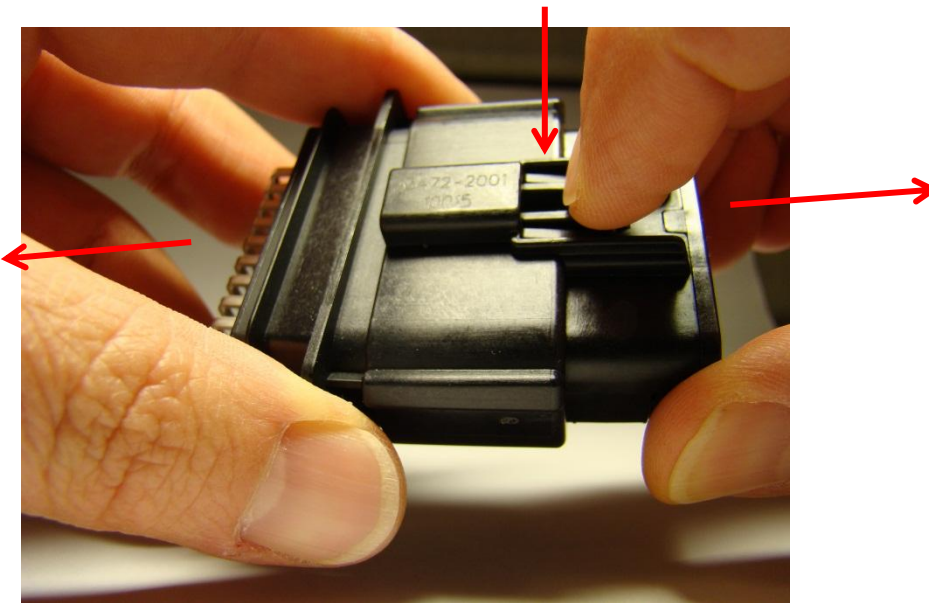

REVISION: A	ECR/ECN INFORMATION: EC No: UAU2013-1201 DATE: 2013/01/29	TITLE: Application Specification MX150 Dual Row Right Angle Header	SHEET No. 11 of 12
DOCUMENT NUMBER: AS-34829-001	CREATED / REVISED BY: Tim Skiver	CHECKED BY: Chris Taylor	APPROVED BY: Paul Berg

MX150 DUAL ROW RIGHT ANGLE HEADER

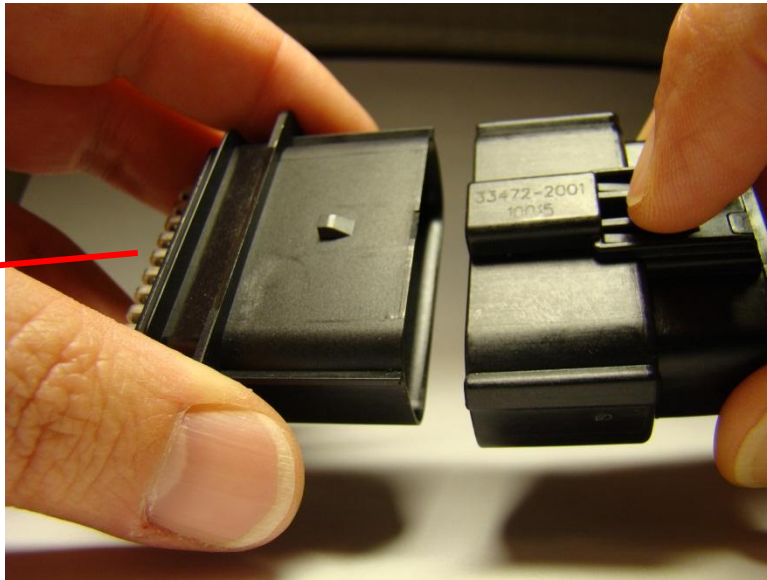

REVISION INFORMATION:

REVISION	DATE	DESCRIPTION
A	10/30/2012	Initial Release

NOTE: PLEASE REFER TO MOLEX.COM TO ENSURE THE LATEST REVISION OF THIS DOCUMENT

Example : <http://midasweb.global.molex.com:7041/midas/FileDownloadServlet?elid=BZWRAFK6>

REVISION: A	ECR/ECN INFORMATION: EC No: UAU2013-1201 DATE: 2013/01/29	TITLE: Application Specification MX150 Dual Row Right Angle Header	SHEET No. 12 of 12
DOCUMENT NUMBER: AS-34829-001	CREATED / REVISED BY: Tim Skiver	CHECKED BY: Chris Taylor	APPROVED BY: Paul Berg