

CIRCUIT SIZE	DIM. "A"	DIM. "B"	DIM. "C"	DIM. "D"
6	.54 (13.8)	.33 (8.4)	.807 (20.50)	.945 (24.00)
8	.71 (18.0)	.50 (12.6)	.972 (24.70)	1.110 (28.20)
10	.87 (22.2)	.66 (16.8)	1.138 (28.90)	1.276 (32.40)
12	1.04 (26.4)	.83 (21.0)	1.303 (33.10)	1.441 (36.60)
14	1.20 (30.6)	.99 (25.2)	1.469 (37.30)	1.606 (40.80)
16	1.37 (34.8)	1.16 (29.4)	1.643 (41.50)	1.772 (45.00)
18	1.54 (39.0)	1.32 (33.6)	1.799 (45.70)	1.937 (49.20)
20	1.70 (43.2)	1.49 (37.8)	1.965 (49.90)	2.102 (53.40)
22	1.87 (47.4)	1.65 (42.0)	2.130 (54.10)	2.268 (57.60)
24	2.03 (51.6)	1.82 (46.2)	2.295 (58.30)	2.433 (61.80)

- NOTES:
- MATERIAL:
 - NYLON (PA6/6), UNFILLED, UL94 V-2, COLOR: NATURAL
 - NYLON (PA6/6), UNFILLED, UL94 V-0, COLOR: NATURAL (WHITE)
 - NYLON (PA6/6), UNFILLED, UL94 V-2, COLOR: BLACK
 - NYLON (PA6/6), UNFILLED, UL94 V-0, COLOR: BLACK
 - FINISH NOT APPLICABLE.
 - PRODUCT SPECIFICATION: PS-5556-002
 - PACKAGING SPECIFICATION: PK-42474-001
 - 6-24 CKT. PARTS MATE WITH MOLEX RECEPTACLES 5557, 42385 AND 42474. 2 AND 4 CKT. PARTS MATE WITH 42385 AND 42474 ONLY.
 - PART IS FOR USE WITH MALE TERMINAL #5558.
 - PART ALLOWS FOR UP TO .100/(2.54) MISALIGNMENT WITH MATING RECEPTACLE IN ANY DIRECTION. SEE MATING CONNECTOR DRAWINGS FOR SPECIFIC ALLOWANCES.
 - PANEL CUT-OUT TO BE PUNCHED IN THE SAME DIRECTION AS CONNECTOR INSERTION.
 - PART CONFORMS TO CLASS "B" REQUIREMENTS OF COSMETIC SPECIFICATION PS-45499-022.

- FOR MANUFACTURING EASE PARTS MAY HAVE OPTIONAL EJECTOR RIBS. SEE SHT. 3 FOR LOCATION.
- DIMENSION DOES NOT INCLUDE EJECTOR RIBS (SEE PAGE #3 FOR PARTS WITH RIBS, RIB DIMENSIONS AND LOCATION).
- IF THIS PRODUCT IS STORED IN AN ENVIRONMENT WITH A RELATIVE HUMIDITY OF LESS THAN 50%, MOISTURE MUST BE ADDED. REFER TO TECHNICAL ADVISORY AS-45499-001 FOR INSTRUCTIONS.
- INTERIOR RIB LOCATION MAY VARY.

- CONNECTOR ASSEMBLIES ARE NOT TO BE MATED OR UNMATED WHILE CIRCUITS ARE LIVE.
- WIRES ARE TO BE DRESSED IN SUCH A MANNER TO ALLOW THE TERMINALS TO FLOAT FREELY IN THE POCKET.
- PARTS MAY HAVE OPTIONAL GUSSET

SEE SHEET 2 FOR 2 & 4 CKT. PARTS

ADD MIN PANEL EC NO: UCP2015-4971 DRWNG: SLAFER CHKD: BELL APPR: FSMITH 2016/04/01 2016/04/01 2016/04/05	QUALITY SYMBOLS ▽=0 ▽=0 ▽=0	GENERAL TOLERANCES (UNLESS SPECIFIED)		DIMENSION STYLE IN/MM		SCALE 4:1	DESIGN UNITS METRIC	THIRD ANGLE PROJECTION			
		4 PLACES ± --- ± ---	3 PLACES ± --- ± .010	DRAWN BY GEP	DATE 1989/07/18	PLUG HOUSING B.M.I. 2-24 CIRCUITS MINI-FIT SERIES					
		2 PLACES ± 0.25 ± .015	1 PLACE ± 0.38 ± ---	CHECKED BY RJF	DATE 1989/07/18						
		ANGULAR ± 1/2°		APPROVED BY FSMITH		DATE 2011/09/02	MATERIAL NO. SEE SHEET 4		DOCUMENT NO. SD-42475-***1	SHEET NO. 1 OF 4	

DRAFT WHERE APPLICABLE MUST REMAIN WITHIN DIMENSIONS

THIS DRAWING CONTAINS INFORMATION THAT IS PROPRIETARY TO MOLEX INCORPORATED AND SHOULD NOT BE USED WITHOUT WRITTEN PERMISSION

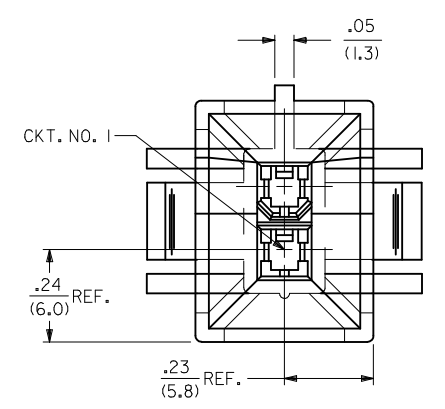
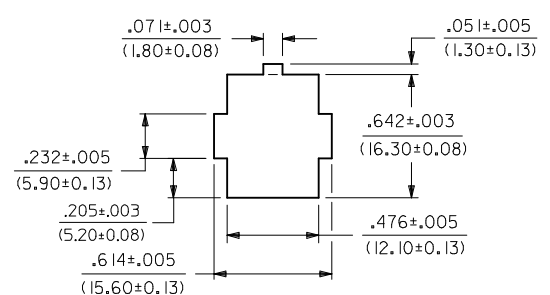
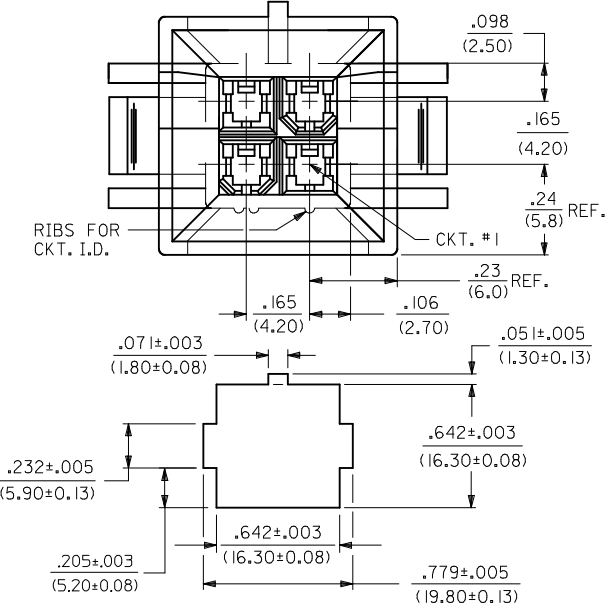
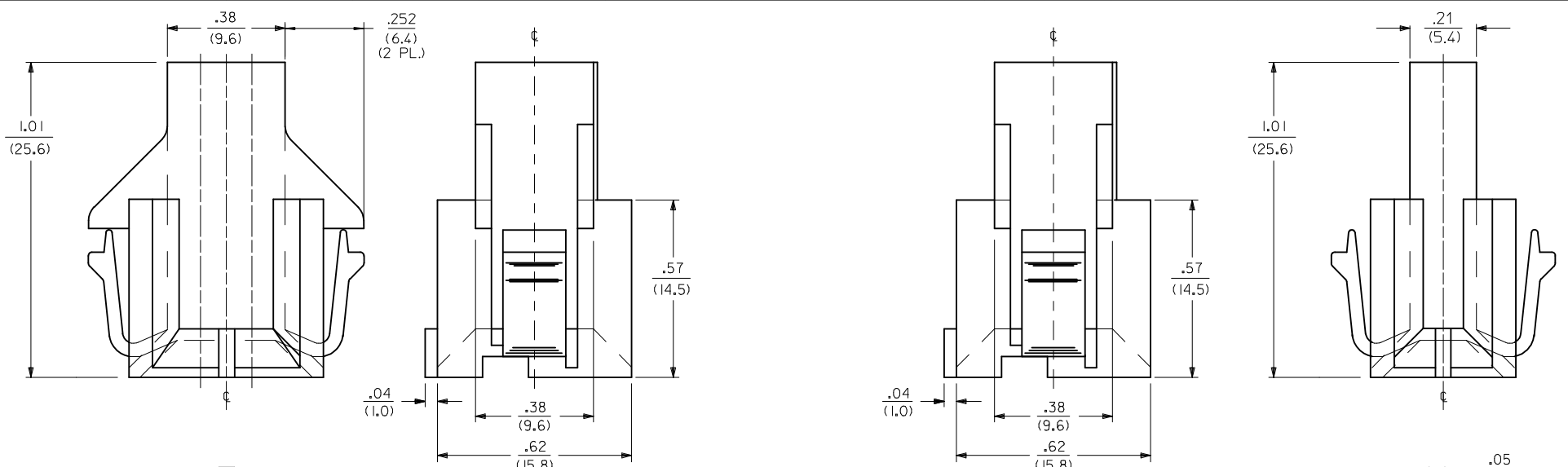

RECOMMENDED CUT-OUT FOR .063/(1.60)
MAX. THICK PANEL (4 CKT'S.)
SCALE: 2X

RECOMMENDED CUT-OUT FOR .063/(1.60)
MAX. THICK PANEL #1 (2 CKT'S.)
SCALE: 2X

2 CKT.

4 CKT.

SEE SHEET 1 EC NO: UCP2015-4971 DRWNSLAFATER 2016/04/01 CHKD:JBELL 2016/04/01 APPR:FSMITH 2016/04/05 S14	QUALITY SYMBOLS ∇=0 ∇=0 ∇=0	GENERAL TOLERANCES (UNLESS SPECIFIED) mm INCH 4 PLACES ± --- ± --- 3 PLACES ± --- ± .010 2 PLACES ± 0.25 ± .015 1 PLACE ± 0.38 ± --- ANGULAR ± 1/2°	DIMENSION STYLE IN/MM DRAWN BY DATE GEP 1989/07/18 CHECKED BY DATE RJF 1989/07/18 APPROVED BY DATE FSMITH 2011/09/02	SCALE 4:1 DESIGN UNITS METRIC THIRD ANGLE PROJECTION	TITLE PLUG HOUSING B.M.I. 2-24 CIRCUITS MINI-FIT SERIES	MATERIAL NO. SEE SHEET 4 DOCUMENT NO. SD-42475-***1	SHEET NO. 2 OF 4	
	DRAFT WHERE APPLICABLE MUST REMAIN WITHIN DIMENSIONS		THIS DRAWING CONTAINS INFORMATION THAT IS PROPRIETARY TO MOLEX INCORPORATED AND SHOULD NOT BE USED WITHOUT WRITTEN PERMISSION					

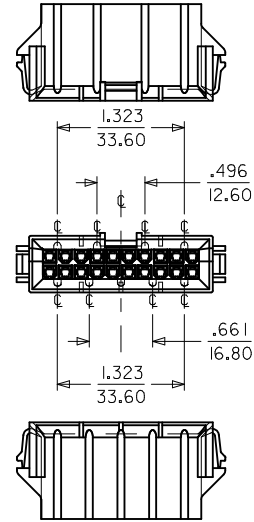

20 CIRCUIT

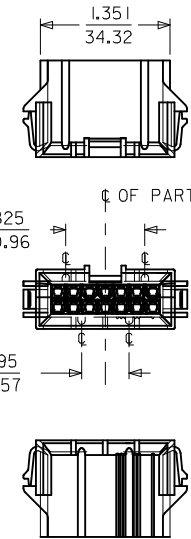

OR

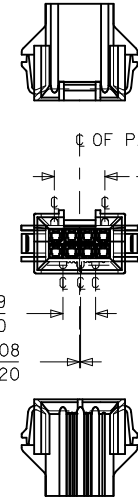

8 CIRCUIT

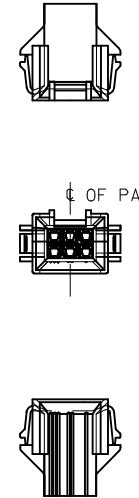

6 CIRCUIT

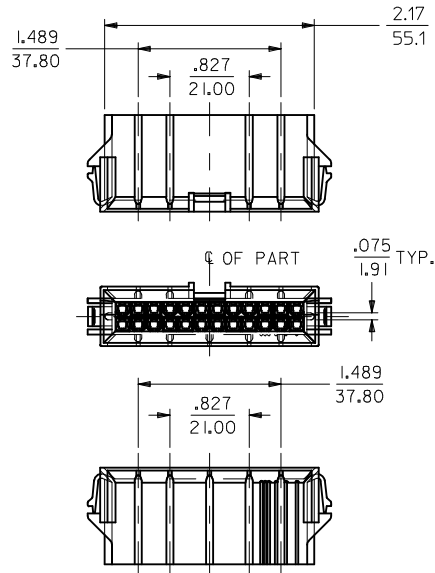

24 CIRCUIT

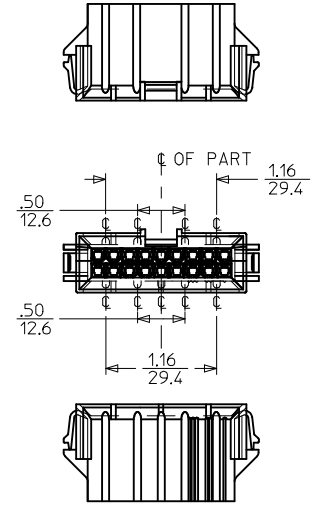

18 CIRCUIT

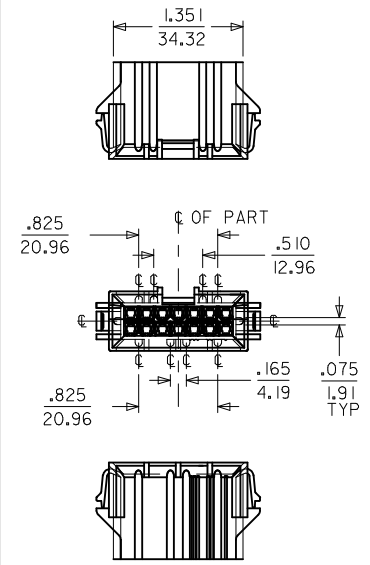

14 CIRCUIT

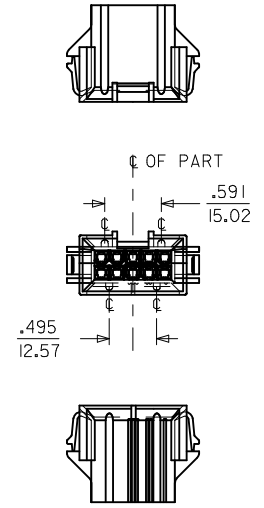

10 CIRCUIT

NOTES:

1) DIMENSIONS GIVEN ACROSS CENTERLINES ARE SYMMETRICAL ABOUT THOSE CENTERLINES WITHIN HALF THE TOTAL TOLERANCE.

SEE SHEET 1 EC NO: UCP2015-4971 DRAWN: SLAFTER 2016/04/01 CHKD: BELL 2016/04/01 APPR: FSMITH 2016/04/05	QUALITY SYMBOLS ∇=0 ∇=0 ∇=0
---	--------------------------------------

GENERAL TOLERANCES (UNLESS SPECIFIED) 4 PLACES ± --- ± --- 3 PLACES ± --- ± .010 2 PLACES ± 0.25 ± .015 1 PLACE ± 0.38 ± --- ANGULAR ± 1/2° DRAFT WHERE APPLICABLE MUST REMAIN WITHIN DIMENSIONS
--

DIMENSION STYLE IN/MM DRAWN BY: GEP CHECKED BY: RJF APPROVED BY: FSMITH DATE: 1989/07/18 DATE: 1989/07/18 DATE: 2011/09/02

SCALE 1:1 DESIGN UNITS METRIC THIRD ANGLE PROJECTION TITLE: PLUG HOUSING B.M.I. 2-24 CIRCUITS MINI-FIT SERIES MATERIAL NO. SD-42475-***1 SHEET NO. 3 OF 4 THIS DRAWING CONTAINS INFORMATION THAT IS PROPRIETARY TO MOLEX INCORPORATED AND SHOULD NOT BE USED WITHOUT WRITTEN PERMISSION

	13	12	11	10	9	8	7	6	5	4	3	2	1
	PART NUMBER	ENG. NUMBER	CKT. SIZE	MATERIAL (SEE NOTE 1.)		PART NUMBER	CKT. SIZE	MATERIAL (SEE NOTE 1.)					
J	NOT TOOLED	42475-0211	2	1		NOT TOOLED	2	3					
	I5-06-0045	42475-0411	4	↑		42475-0431	4	↑					
	I5-06-0065	42475-0611	6			42475-0631	6						
	I5-06-0085	42475-0811	8			42475-0831	8						
I	I5-06-0105	42475-1011	10			42475-1031	10						
	NOT TOOLED	42475-1211	12			NOT TOOLED	12						
	I5-06-0145	42475-1411	14			42475-1431	14						
	NOT TOOLED	42475-1611	16			NOT TOOLED	16						
H	I5-06-0185	42475-1811	18			42475-1831	18						
O	I5-06-0205	42475-2011	20			O 42475-2031	20						
	NOT TOOLED	42475-2211	22	↓		NOT TOOLED	22	↓					
	I5-06-0245	42475-2411	24	1		42475-2431	24	3					
G													
	NOT TOOLED	42475-0221	2	2		NOT TOOLED	2	4					
	I5-06-0046	42475-0421	4	↑		42475-0441	4	↑					
	I5-06-0066	42475-0621	6			42475-0641	6						
F	50-36-2323	42475-0821	8			42475-0841	8						
	I5-06-0106	42475-1021	10			42475-1041	10						
	NOT TOOLED	42475-1221	12			NOT TOOLED	12						
	I5-06-0146	42475-1421	14			42475-1441	14						
E	NOT TOOLED	42475-1621	16			NOT TOOLED	16						
	I5-06-0186	42475-1821	18			42475-1841	18						
O	I5-06-0206	42475-2021	20			O 42475-2041	20						
	NOT TOOLED	42475-2221	22	↓		NOT TOOLED	22	↓					
D	I5-06-0246	42475-2421	24	2		42475-2441	24	4					

O = OBSOLETE

O = OBSOLETE

LEGEND:

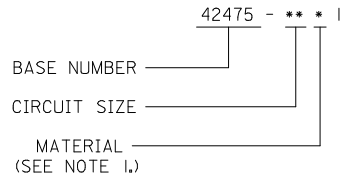

SEE SHEET 1 EC NO: UCP2015-4971 DRWNSLAFTER 2016/04/01 CHKD:JBELL 2016/04/01 APPR:FSMITH 2016/04/05	QUALITY SYMBOLS 	GENERAL TOLERANCES (UNLESS SPECIFIED)		DIMENSION STYLE IN/MM		SCALE 1:1	DESIGN UNITS METRIC	THIRD ANGLE PROJECTION			
				mm	INCH	DRAWN BY GEP	DATE 1989/07/18	TITLE PLUG HOUSING B.M.I. 2-24 CIRCUITS MINI-FIT SERIES			
				4 PLACES ± ---	± ---	CHECKED BY RJF	DATE 1989/07/18				
				3 PLACES ± ---	± .010	APPROVED BY FSMITH		DATE 2011/09/02	MOLEX INCORPORATED		SHEET NO. 4 OF 4

ANGULAR ±1/2°

DRAFT WHERE APPLICABLE MUST REMAIN WITHIN DIMENSIONS

SEE CHART

DOCUMENT NO. SD-42475-***1

THIS DRAWING CONTAINS INFORMATION THAT IS PROPRIETARY TO MOLEX INCORPORATED AND SHOULD NOT BE USED WITHOUT WRITTEN PERMISSION

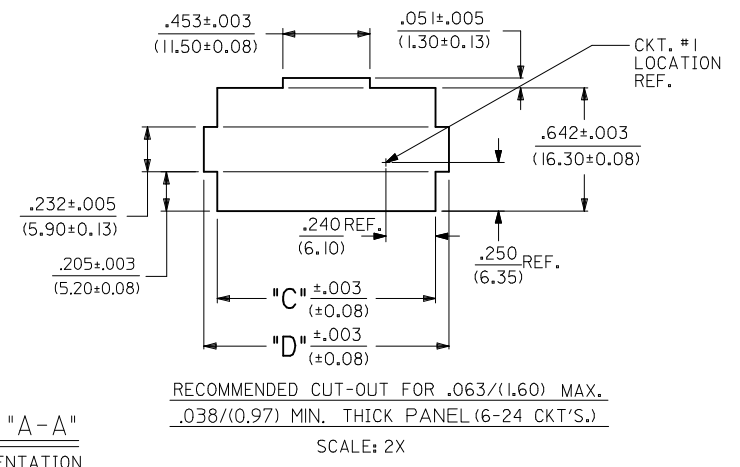
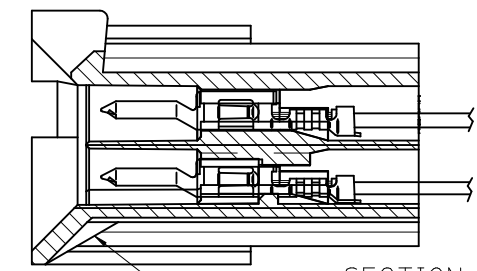
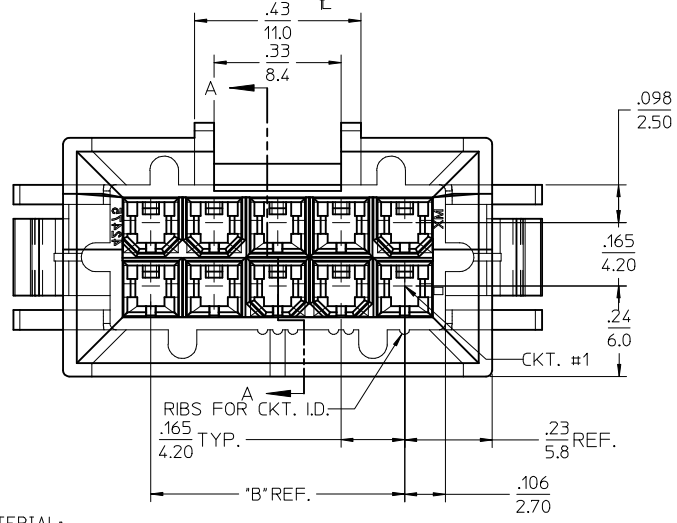
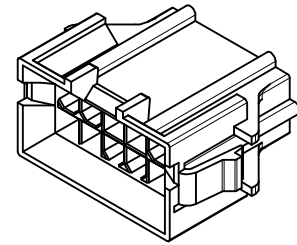
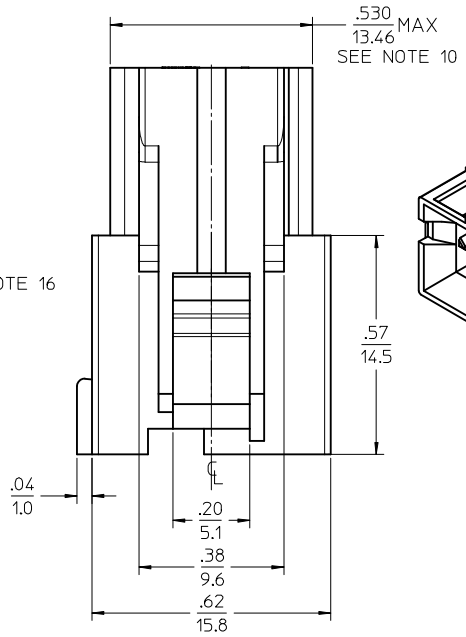
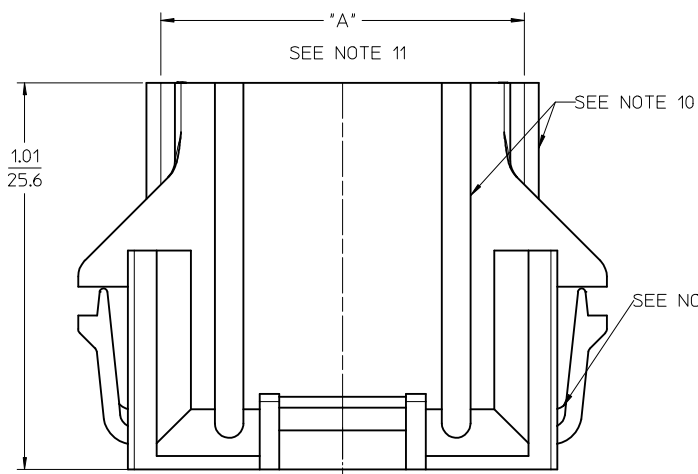

CIRCUIT SIZE	DIM. "A"	DIM. "B"	DIM. "C"	DIM. "D"
6	.54 (13.8)	.33 (8.4)	.807 (20.50)	.945 (24.00)
8	.71 (18.0)	.50 (12.6)	.972 (24.70)	1.110 (28.20)
10	.87 (22.2)	.66 (16.8)	1.138 (28.90)	1.276 (32.40)
12	1.04 (26.4)	.83 (21.0)	1.303 (33.10)	1.441 (36.60)
14	1.20 (30.6)	.99 (25.2)	1.469 (37.30)	1.606 (40.80)
16	1.37 (34.8)	1.16 (29.4)	1.643 (41.50)	1.772 (45.00)
18	1.54 (39.0)	1.32 (33.6)	1.799 (45.70)	1.937 (49.20)
20	1.70 (43.2)	1.49 (37.8)	1.965 (49.90)	2.102 (53.40)
22	1.87 (47.4)	1.65 (42.0)	2.130 (54.10)	2.268 (57.60)
24	2.03 (51.6)	1.82 (46.2)	2.295 (58.30)	2.433 (61.80)

- NOTES:
- MATERIAL:
 - 1 = NYLON (PA6/6), UNFILLED, UL94 V-2, COLOR: NATURAL
 - 2 = NYLON (PA6/6), UNFILLED, UL94 V-0, COLOR: NATURAL (WHITE)
 - 3 = NYLON (PA6/6), UNFILLED, UL94 V-2, COLOR: BLACK
 - 4 = NYLON (PA6/6), UNFILLED, UL94 V-0, COLOR: BLACK
 - FINISH NOT APPLICABLE.
 - PRODUCT SPECIFICATION: PS-5556-002
 - PACKAGING SPECIFICATION: PK-42474-001
 - 6-24 CKT. PARTS MATE WITH MOLEX RECEPTACLES 5557, 42385 AND 42474. 2 AND 4 CKT. PARTS MATE WITH 42385 AND 42474 ONLY.
 - PART IS FOR USE WITH MALE TERMINAL #5558.
 - PART ALLOWS FOR UP TO .100/(2.54) MISALIGNMENT WITH MATING RECEPTACLE IN ANY DIRECTION. SEE MATING CONNECTOR DRAWINGS FOR SPECIFIC ALLOWANCES.
 - PANEL CUT-OUT TO BE PUNCHED IN THE SAME DIRECTION AS CONNECTOR INSERTION.
 - PART CONFORMS TO CLASS "B" REQUIREMENTS OF COSMETIC SPECIFICATION PS-45499-022.

- FOR MANUFACTURING EASE PARTS MAY HAVE OPTIONAL EJECTOR RIBS. SEE SHT. 3 FOR LOCATION.
- DIMENSION DOES NOT INCLUDE EJECTOR RIBS (SEE PAGE #3 FOR PARTS WITH RIBS, RIB DIMENSIONS AND LOCATION).
- IF THIS PRODUCT IS STORED IN AN ENVIRONMENT WITH A RELATIVE HUMIDITY OF LESS THAN 50%, MOISTURE MUST BE ADDED. REFER TO TECHNICAL ADVISORY AS-45499-001 FOR INSTRUCTIONS.
- INTERIOR RIB LOCATION MAY VARY.

- CONNECTOR ASSEMBLIES ARE NOT TO BE MATED OR UNMATED WHILE CIRCUITS ARE LIVE.
- WIRES ARE TO BE DRESSED IN SUCH A MANNER TO ALLOW THE TERMINALS TO FLOAT FREELY IN THE POCKET.
- PARTS MAY HAVE OPTIONAL GUSSET

RECOMMENDED CUT-OUT FOR .063/(1.60) MAX., .038/(0.97) MIN. THICK PANEL (6-24 CKT.'S.)
SCALE: 2X

SEE SHEET 2 FOR 2 & 4 CKT. PARTS

ADD MIN PANEL EC NO: UCP2015-4971 DRWNG: SLAFER CHKD: BELL APPR: FSMITH 2016/04/01 2016/04/01 2016/04/05	QUALITY SYMBOLS ∇=0 ∇=0 ∇=0	GENERAL TOLERANCES (UNLESS SPECIFIED)		DIMENSION STYLE		SCALE	DESIGN UNITS	THIRD ANGLE PROJECTION	
				IN/MM		4:1	METRIC		
				DRAWN BY DATE		TITLE			
				CHECKED BY DATE					
S14	DESCRIPTION	4 PLACES ± --- ± ---		GEP 1989/07/18		PLUG HOUSING B.M.I. 2-24 CIRCUITS MINI-FIT SERIES MOLEX INCORPORATED SD-42475-***1			
		3 PLACES ± --- ± .010		RJV 1989/07/18					
		2 PLACES ± 0.25 ± .015		APPROVED BY DATE					
		1 PLACE ± 0.38 ± ---		FSMITH 2011/09/02		MATERIAL NO.		DOCUMENT NO.	
		ANGULAR ±1/2°		SEE SHEET 4		SHEET NO.		1 OF 4	
		DRAFT WHERE APPLICABLE MUST REMAIN WITHIN DIMENSIONS		THIS DRAWING CONTAINS INFORMATION THAT IS PROPRIETARY TO MOLEX INCORPORATED AND SHOULD NOT BE USED WITHOUT WRITTEN PERMISSION					

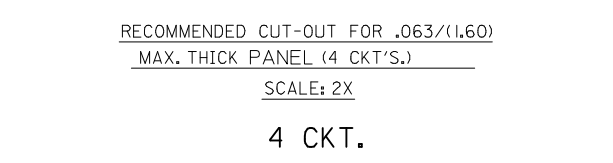
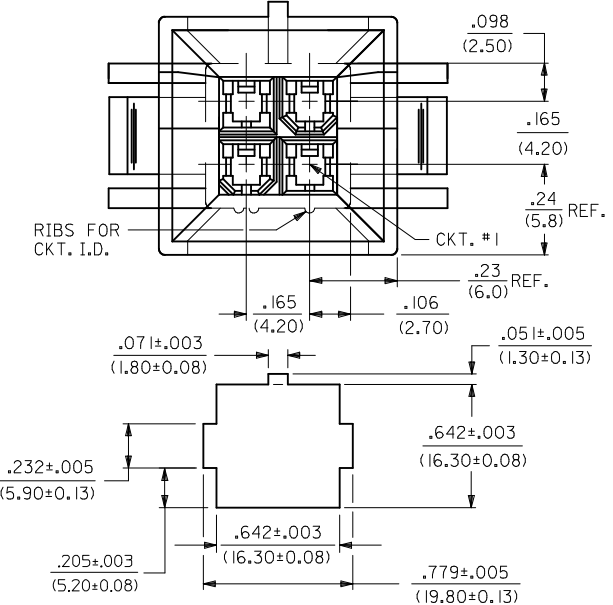
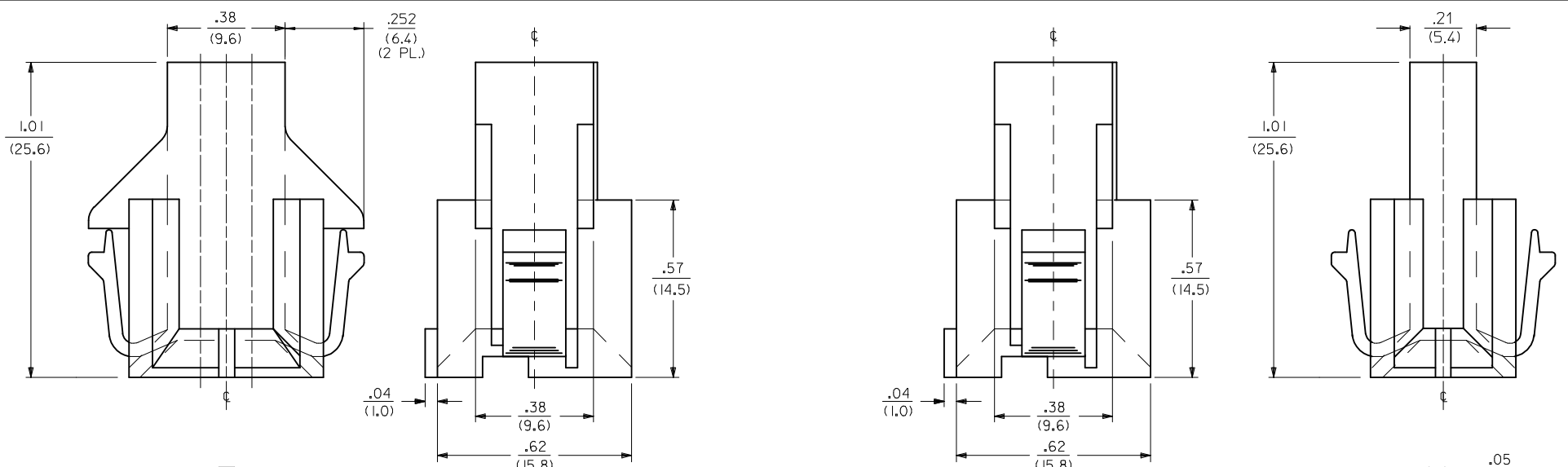

RECOMMENDED CUT-OUT FOR .063/(1.60)
 MAX. THICK PANEL (4 CKT'S.)
 SCALE: 2X

4 CKT.

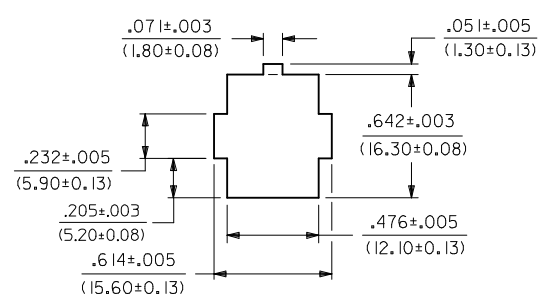

RECOMMENDED CUT-OUT FOR .063/(1.60)
 MAX. THICK PANEL #1 (2 CKT'S.)

SCALE: 2X

2 CKT.

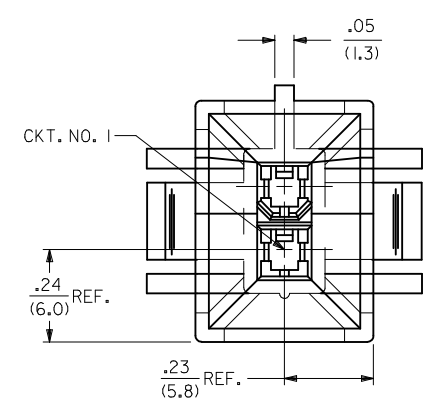

SEE SHEET 1 EC NO: UCP2015-4971 DRWNSLAFATER 2016/04/01 CHKD:JBELL 2016/04/01 APPR:FSMITH 2016/04/05 S14	QUALITY SYMBOLS ▽=0 ▽=0 ▽=0	GENERAL TOLERANCES (UNLESS SPECIFIED) mm INCH 4 PLACES ± --- ± --- 3 PLACES ± --- ± .010 2 PLACES ± 0.25 ± .015 1 PLACE ± 0.38 ± --- ANGULAR ± 1/2°	DIMENSION STYLE IN/MM DRAWN BY DATE GEP 1989/07/18 CHECKED BY DATE RJF 1989/07/18 APPROVED BY DATE FSMITH 2011/09/02	SCALE 4:1 DESIGN UNITS METRIC THIRD ANGLE PROJECTION	TITLE PLUG HOUSING B.M.I. 2-24 CIRCUITS MINI-FIT SERIES	MATERIAL NO. SEE SHEET 4 SIZE C	DOCUMENT NO. SD-42475-***1	SHEET NO. 2 OF 4	
	DRAFT WHERE APPLICABLE MUST REMAIN WITHIN DIMENSIONS		THIS DRAWING CONTAINS INFORMATION THAT IS PROPRIETARY TO MOLEX INCORPORATED AND SHOULD NOT BE USED WITHOUT WRITTEN PERMISSION						
	MOLEX MOLEX INCORPORATED								
	Molex logo								

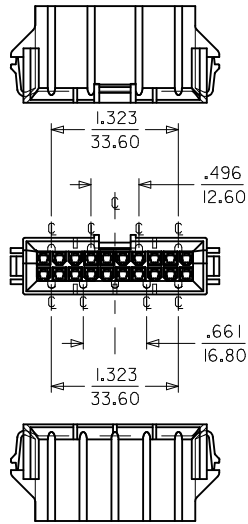

20 CIRCUIT

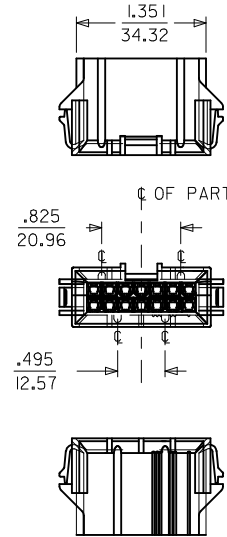

OR

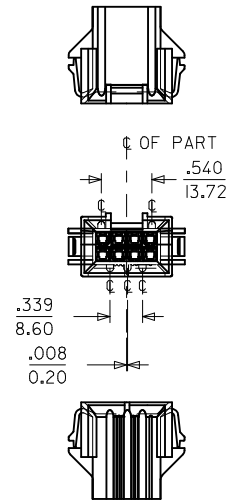

8 CIRCUIT

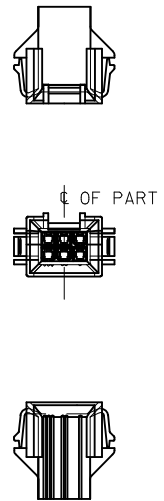

6 CIRCUIT

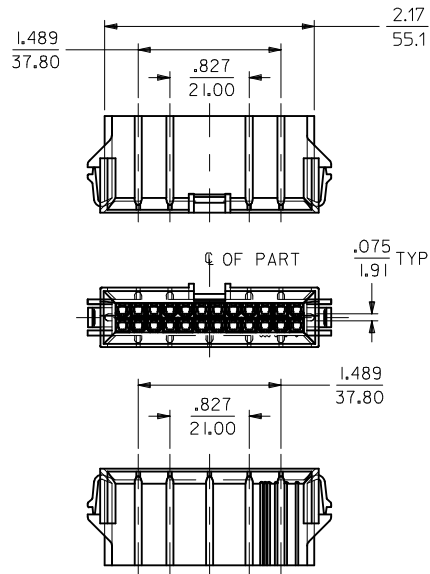

24 CIRCUIT

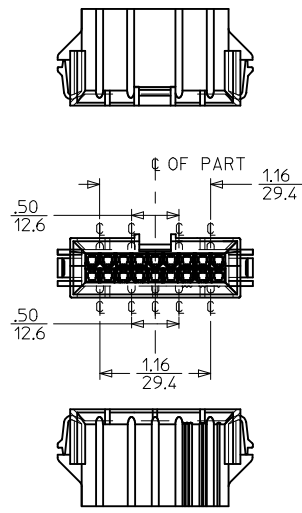

18 CIRCUIT

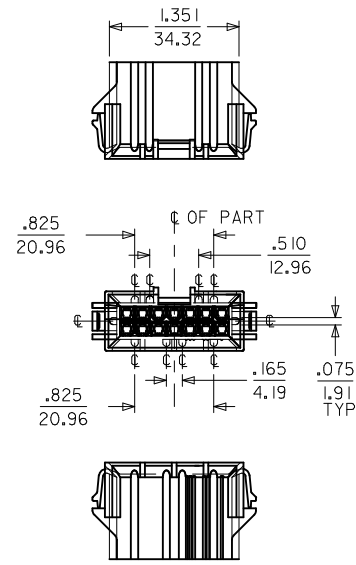

14 CIRCUIT

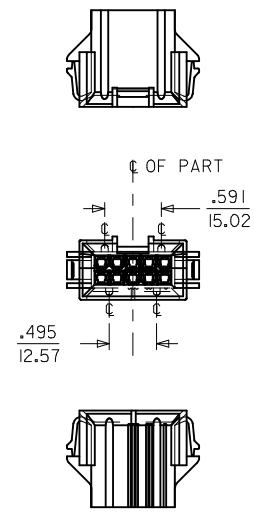

10 CIRCUIT

NOTES:

1) DIMENSIONS GIVEN ACROSS CENTERLINES ARE SYMMETRICAL ABOUT THOSE CENTERLINES WITHIN HALF THE TOTAL TOLERANCE.

SEE SHEET 1 EC NO: UCP2015-4971 DRAWN: SLAFTER 2016/04/01 CHKD: BELL 2016/04/01 APPR: FSMITH 2016/04/05	QUALITY SYMBOLS ∇=0 ∇=0 ∇=0
---	--------------------------------------

GENERAL TOLERANCES (UNLESS SPECIFIED) 4 PLACES ± --- ± --- 3 PLACES ± --- ± .010 2 PLACES ± 0.25 ± .015 1 PLACE ± 0.38 ± --- ANGULAR ± 1/2° DRAFT WHERE APPLICABLE MUST REMAIN WITHIN DIMENSIONS
--

DIMENSION STYLE IN/MM DRAWN BY GEP CHECKED BY RJF APPROVED BY FSMITH DATE 1989/07/18 DATE 1989/07/18 DATE 2011/09/02

SCALE 1:1 DESIGN UNITS METRIC THIRD ANGLE PROJECTION	TITLE PLUG HOUSING B.M.I. 2-24 CIRCUITS MINI-FIT SERIES	MATERIAL NO. SEE SHEET 4 SIZE C	DOCUMENT NO. SD-42475-***1 SHEET NO. 3 OF 4
--	--	--	--

	13	12	11	10	9	8	7	6	5	4	3	2	1
	PART NUMBER	ENG. NUMBER	CKT. SIZE	MATERIAL (SEE NOTE 1.)		PART NUMBER	CKT. SIZE	MATERIAL (SEE NOTE 1.)					
J	NOT TOOLED	42475-0211	2	1		NOT TOOLED	2	3					
	15-06-0045	42475-0411	4	↑		42475-0431	4	↑					
	15-06-0065	42475-0611	6			42475-0631	6						
	15-06-0085	42475-0811	8			42475-0831	8						
I	15-06-0105	42475-1011	10			42475-1031	10						
	NOT TOOLED	42475-1211	12			NOT TOOLED	12						
	15-06-0145	42475-1411	14			42475-1431	14						
	NOT TOOLED	42475-1611	16			NOT TOOLED	16						
H	15-06-0185	42475-1811	18			42475-1831	18						
O	15-06-0205	42475-2011	20			O 42475-2031	20						
	NOT TOOLED	42475-2211	22	↓		NOT TOOLED	22	↓					
	15-06-0245	42475-2411	24	1		42475-2431	24	3					
G													
	NOT TOOLED	42475-0221	2	2		NOT TOOLED	2	4					
	15-06-0046	42475-0421	4	↑		42475-0441	4	↑					
	15-06-0066	42475-0621	6			42475-0641	6						
F	50-36-2323	42475-0821	8			42475-0841	8						
	15-06-0106	42475-1021	10			42475-1041	10						
	NOT TOOLED	42475-1221	12			NOT TOOLED	12						
	15-06-0146	42475-1421	14			42475-1441	14						
E	NOT TOOLED	42475-1621	16			NOT TOOLED	16						
	15-06-0186	42475-1821	18			42475-1841	18						
O	15-06-0206	42475-2021	20			O 42475-2041	20						
	NOT TOOLED	42475-2221	22	↓		NOT TOOLED	22	↓					
D	15-06-0246	42475-2421	24	2		42475-2441	24	4					

O = OBSOLETE

O = OBSOLETE

LEGEND:

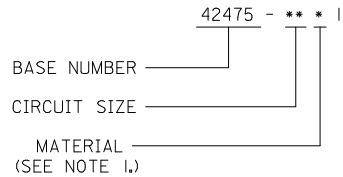

SEE SHEET 1 EC NO: UCP2015-4971 DRWNSLAFTER 2016/04/01 CHKD:JBELL 2016/04/01 APPR:FSMITH 2016/04/05	QUALITY SYMBOLS 	GENERAL TOLERANCES (UNLESS SPECIFIED)		DIMENSION STYLE IN/MM		SCALE 1:1	DESIGN UNITS METRIC	THIRD ANGLE PROJECTION			
				mm	INCH	DRAWN BY GEP	DATE 1989/07/18	TITLE PLUG HOUSING B.M.I. 2-24 CIRCUITS MINI-FIT SERIES			
				4 PLACES ± ---	± ---	CHECKED BY RJF	DATE 1989/07/18				
				3 PLACES ± ---	± .010	APPROVED BY FSMITH		DATE 2011/09/02	MOLEX INCORPORATED DOCUMENT NO. SD-42475-***1 SHEET NO. 4 OF 4		
		2 PLACES ± 0.25	± .015	MATERIAL NO.		SIZE					
		1 PLACE ± 0.38	± ---	DRAFT WHERE APPLICABLE MUST REMAIN WITHIN DIMENSIONS		THIS DRAWING CONTAINS INFORMATION THAT IS PROPRIETARY TO MOLEX INCORPORATED AND SHOULD NOT BE USED WITHOUT WRITTEN PERMISSION					