

- NOTES:  
 1. MATERIAL:  
 1.1 HOUSING: THERMOPLASTIC, HIGH TEMP. HALOGEN FREE, UL94V-0; COLOR: BLACK.  
 1.2 CONTACT: COPPER ALLOY.  
 1.3 FITTING NAIL: COPPER ALLOY.  
 2. FINISH:  
 2.1 CONTACT:  
 GOLD FLASH ON CONTACT AREA AND SOLDER TAIL.  
 NICKEL UNDERPLATING OVERALL.  
 2.2 FITTING NAIL:  
 100µ" MIN. TIN PLATING ON SOLDER TAILS.  
 NICKEL UNDERPLATING OVERALL.  
 3. PRODUCT SPECIFICATION REFER TO PS-48338-002.  
 4. PACKAGING DRAWING REFER TO PK-48338-002.  
 5. TEST SUMMARY REFER TO TS-48338-002.  
 6. LEAD FREE AND ROHS COMPLIANT PRODUCT.  
 7. DATUM D IS THE TOP SURFACE OF PCB.

MOLEX P/N	DIM A	DIM B	DIM C	DIM D	DIM E	PACKING
48338-0052	5.20	6.20	3.20	1.45	2.70	PK-48338-002 PAGE 2
48338-1052						PK-48338-002 PAGE 3
48338-0056	5.60	6.60	3.60	1.85	3.10	PK-48338-002 PAGE 2
48338-1056						PK-48338-002 PAGE 3
48338-0057	5.75	6.75	3.75	2.00	3.25	PK-48338-002 PAGE 2
48338-1057						PK-48338-002 PAGE 3
48338-0065	6.50	7.50	4.50	2.75	4.00	PK-48338-002 PAGE 2
48338-1065						PK-48338-002 PAGE 3
48338-0068	6.80	7.80	4.80	3.05	4.30	PK-48338-002 PAGE 2
48338-1068						PK-48338-002 PAGE 3
48338-0070	7.00	8.00	5.00	3.25	4.50	PK-48338-002 PAGE 2
48338-1070						PK-48338-002 PAGE 3
48338-0075	7.50	8.50	5.50	3.75	5.00	PK-48338-002 PAGE 2
48338-1075						PK-48338-002 PAGE 3
48338-0080	8.00	9.00	6.00	4.25	5.50	PK-48338-002 PAGE 2
48338-1080						PK-48338-002 PAGE 3
48338-0085	8.50	9.50	6.50	4.75	6.00	PK-48338-002 PAGE 2
48338-1085						PK-48338-002 PAGE 3
48338-0088	8.80	9.80	6.80	5.05	6.30	PK-48338-002 PAGE 2
48338-1088						PK-48338-002 PAGE 3
48338-0090	9.00	10.00	7.00	5.25	6.50	PK-48338-002 PAGE 2
48338-1090						PK-48338-002 PAGE 3
48338-0099	9.90	10.90	7.90	6.15	7.40	PK-48338-002 PAGE 2
48338-1099						PK-48338-002 PAGE 3

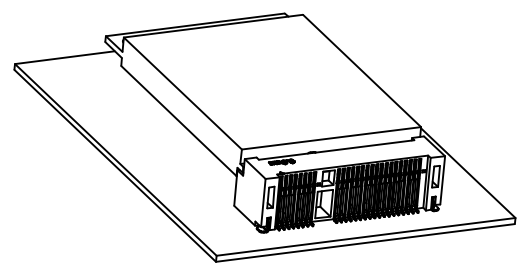

RELEASED EC NO: S2010-0115 DRWN: YLWONG 2009/09/16 CHKD: JESSIE CHUA 2009/09/16 APPR: NAGESHKN 2009/09/16	QUALITY SYMBOLS ▽ = 0 ◻ = 0	GENERAL TOLERANCES (UNLESS SPECIFIED)		DIMENSION STYLE MM ONLY		SCALE NTS	DESIGN UNITS METRIC	THIRD ANGLE PROJECTION			
		4 PLACES ± --- ± --- 3 PLACES ± --- ± --- 2 PLACES ± 0.25 ± --- 1 PLACE ± 0.25 ± ---	mm INCH ± --- ± --- ± 0.25 ± --- ± 0.25 ± ---	DRAWN BY E.K.	DATE 2008/10/07	TITLE MINI PCI EXP.0.8MM PITCH					
		ANGULAR ± 3 °		CHECKED BY DAVID ZHANG	DATE 2008/10/07	MOLEX INCORPORATED					
		DRAFT WHERE APPLICABLE MUST REMAIN WITHIN DIMENSIONS		APPROVED BY HARVEY WANG	DATE 2008/10/07	MATERIAL NO. SEE TABLE	DOCUMENT NO. SD-48338-002	SHEET NO. 1 OF 3			

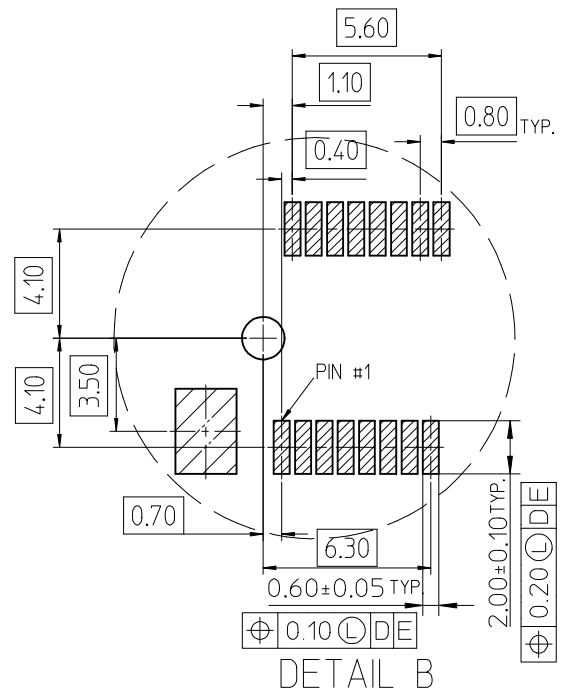
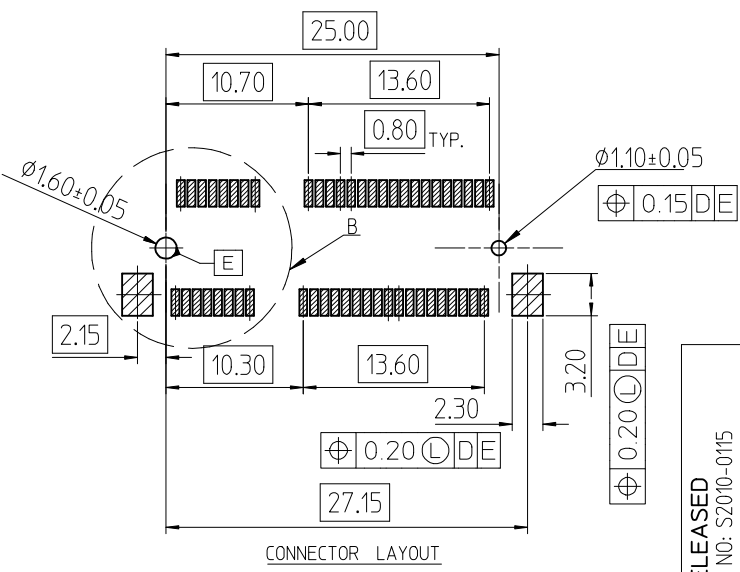
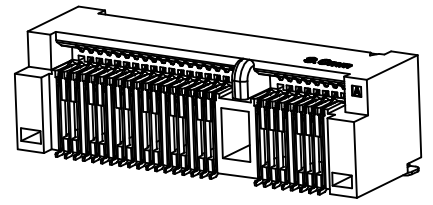
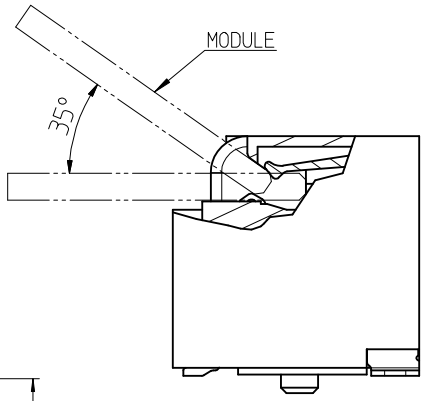
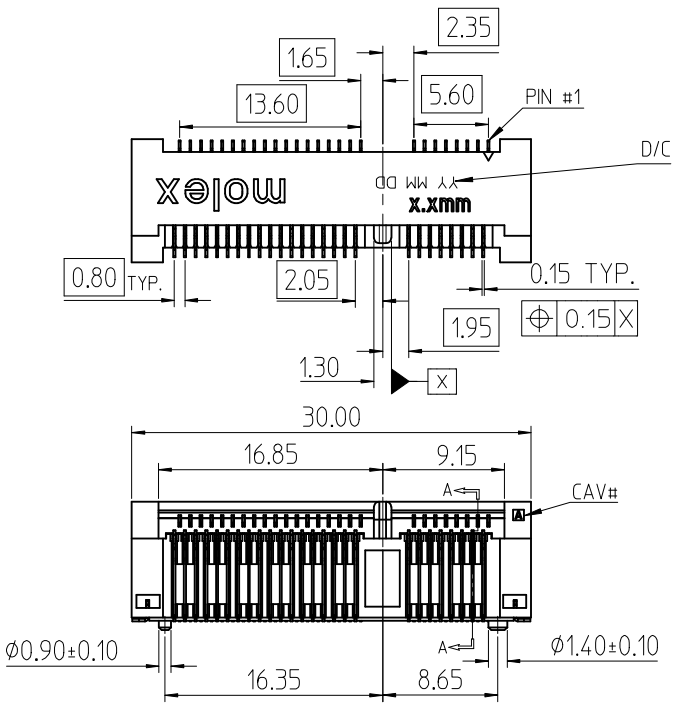

RELEASED EC NO: S2010-0115 DRWN: YLWONG 2009/09/16 CHKD: JESSIE CHUA 2009/09/16 APPR: NAGESH K N 2009/09/16	QUALITY SYMBOLS	GENERAL TOLERANCES (UNLESS SPECIFIED)	DIMENSION STYLE	SCALE	DESIGN UNITS	THIRD ANGLE PROJECTION
	▽=0 ◻=0	mm INCH 4 PLACES ± --- ± --- 3 PLACES ± --- ± --- 2 PLACES ± 0.25 ± --- 1 PLACE ± 0.25 ± --- ANGULAR ± 3 °	MM ONLY	NTS	METRIC	
	DESCRIPTION	TITLE	DRAWN BY	DATE	MINI PCI EXP.0.8MM PITCH	
		SEE TABLE	E.K.	2008/10/07	MOLEX INCORPORATED	
	DRAFT WHERE APPLICABLE MUST REMAIN WITHIN DIMENSIONS	MATERIAL NO.	DOCUMENT NO.		SHEET NO.	
		A3	THIS DRAWING CONTAINS INFORMATION THAT IS PROPRIETARY TO MOLEX INCORPORATED AND SHOULD NOT BE USED WITHOUT WRITTEN PERMISSION		SD-48338-002 2 OF 3	

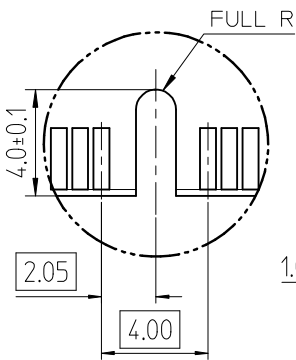
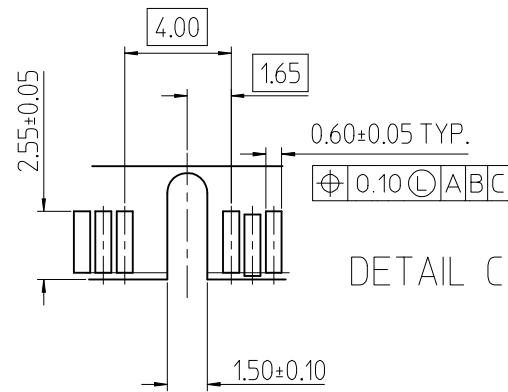
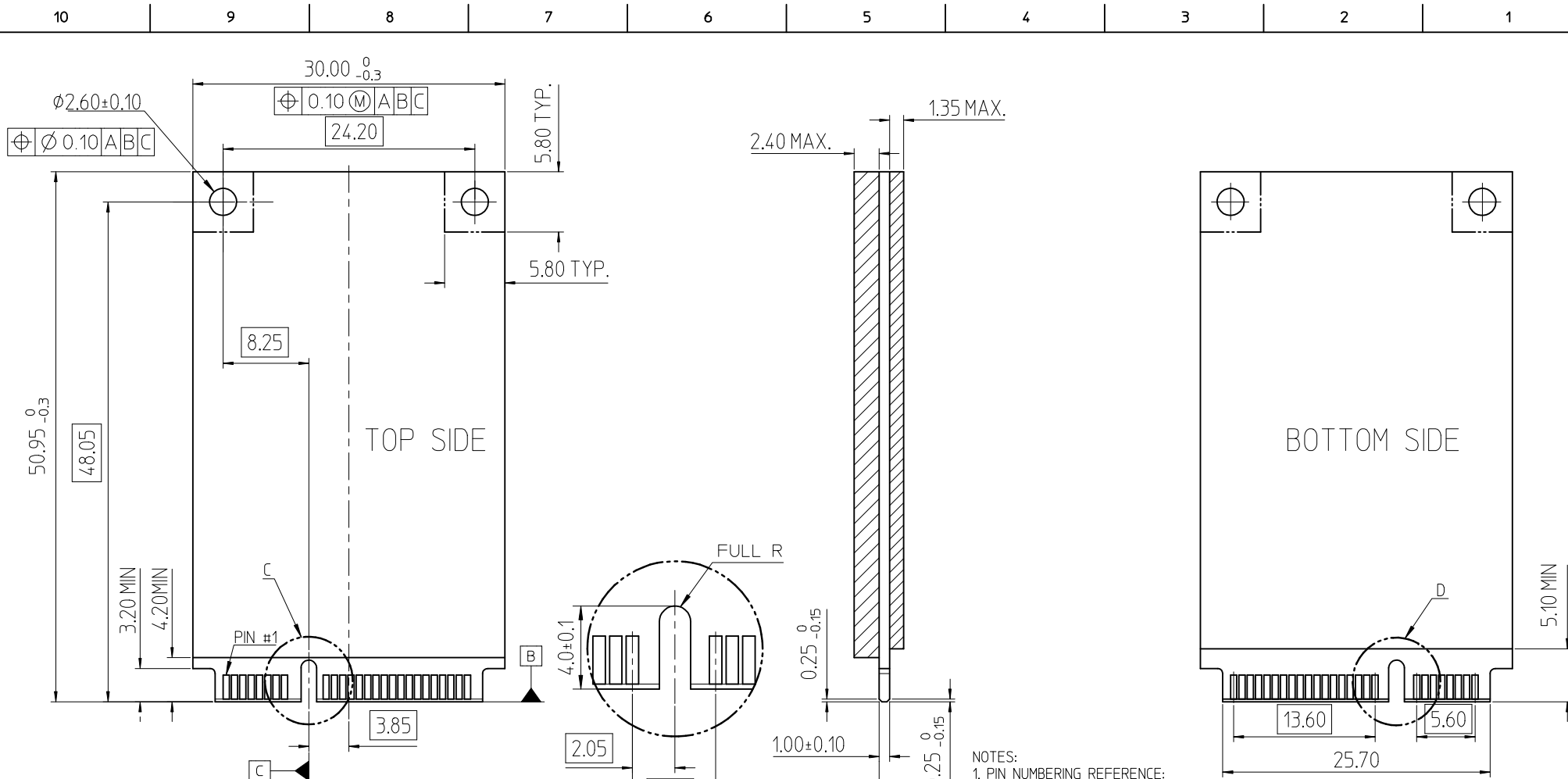

NOTES:  
 1. PIN NUMBERING REFERENCE:  
 ODD PINS: TOP SIDE  
 EVEN PINS: BOTTOM SIDE

<b>RELEASED</b> EC NO: S2010-0115 DRWN: YLWONG 2009/09/16 CHKD: JESSIECHUA 2009/09/16 APPR: NAGESHKN 2009/09/16	QUALITY SYMBOLS ▽=0 ◻=0	GENERAL TOLERANCES (UNLESS SPECIFIED) mm INCH 4 PLACES ± --- ± --- 3 PLACES ± --- ± --- 2 PLACES ± 0.25 ± --- 1 PLACE ± 0.25 ± --- ANGULAR ± 3 °	DIMENSION STYLE <b>MM ONLY</b> DRAWN BY DATE E.K. 2008/10/07 CHECKED BY DATE DAVID ZHANG 2008/10/07 APPROVED BY DATE HARVEY WANG 2008/10/07	SCALE <b>NTS</b> DESIGN UNITS <b>METRIC</b> THIRD ANGLE PROJECTION	TITLE <b>MINI PCI EXP.0.8MM PITCH</b>
	DRAFT WHERE APPLICABLE MUST REMAIN WITHIN DIMENSIONS	MATERIAL NO. <b>SEE TABLE</b>	MOLEX INCORPORATED DOCUMENT NO. <b>SD-48338-002</b>	SHEET NO. <b>3 OF 3</b>	
	SIZE <b>A3</b>	THIS DRAWING CONTAINS INFORMATION THAT IS PROPRIETARY TO MOLEX INCORPORATED AND SHOULD NOT BE USED WITHOUT WRITTEN PERMISSION			