

1. 50079-8000、-8025 梱包仕様
PACKAGING SPECIFICATION

1-1. 製品名称 / PRODUCT NAME : 1.25 WIRE TO BOARD CONN. CRIMP RECEPTACLE TERMINAL
製品番号 / PART NUMBER : 50079-8000
50079-8025

1-2. 標準梱包数 / STANDARD PACKAGING QUANTITY.

1 リールの巻き数 QTY. PER REEL	カートン中のリール数 NUMBER OF REELS	1 カートンの製品数 QUANTITY IN ONE CARTON
25,000	3	75,000

1-3. リール外形参考寸法 / REEL OUTER DIMENSIONS (REFERENCE PURPOSE ONLY)

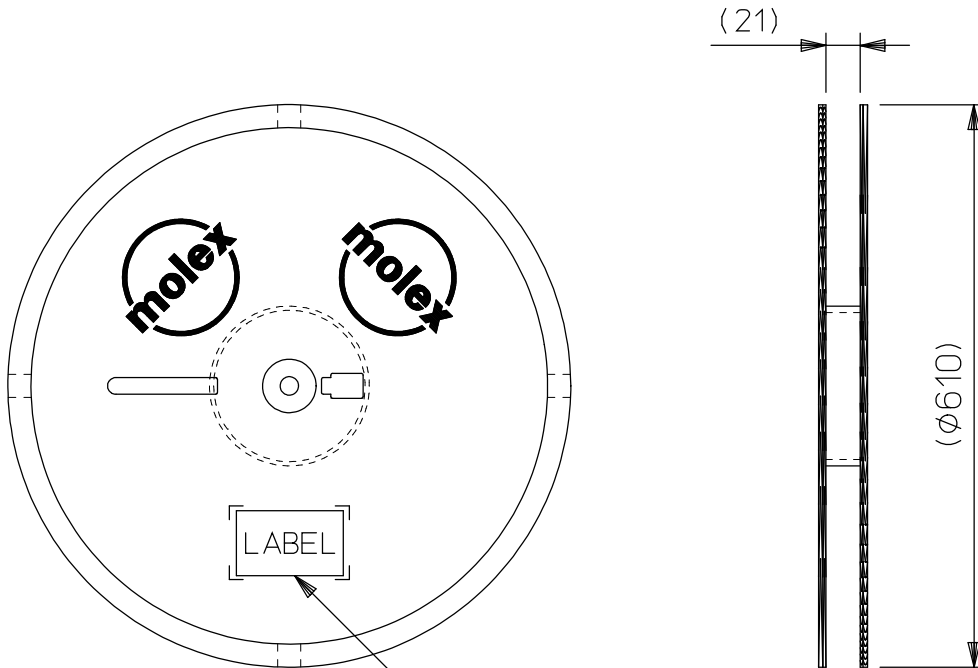

現品票
PART IDENTIFICATION LABEL
(製品型番, 数量, ロットNO. 表示)
INDICATION OF PART No., QUANTITY, LOT No.

REV.	B							
SHEET	1~3							
REVISE ON PC ONLY				TITLE:				
B	REVISED J2015-0161 2014/07/30 Y.TOKUZONO			50079 梱包仕様書 SALES PACKAGING SPEC. FOR 50079				
	THIS DOCUMENT CONTAINS INFORMATION THAT IS PROPRIETARY TO MOLEX INC. AND SHOULD NOT BE USED WITHOUT WRITTEN PERMISSION							
REV.	DESCRIPTION			WRITTEN BY:	CHECKED BY:	APPROVED BY:	DATE: YR/MO/DAY	
	DESIGN CONTROL	STATUS		Y.TOKUZONO	T.HARUYAMA	H.HIRATA	2003/02/05	
DOCUMENT NUMBER							FILE NAME	SHEET
SPK-50079-001							SPK50079001.docx	1 OF 3
EN-037(2013-04 rev.1)								

1-4. カートン外形参考寸法 / CARTON OUTER DIMENSIONS (REFERENCE PURPOSE ONLY)

単位 / UNIT: mm

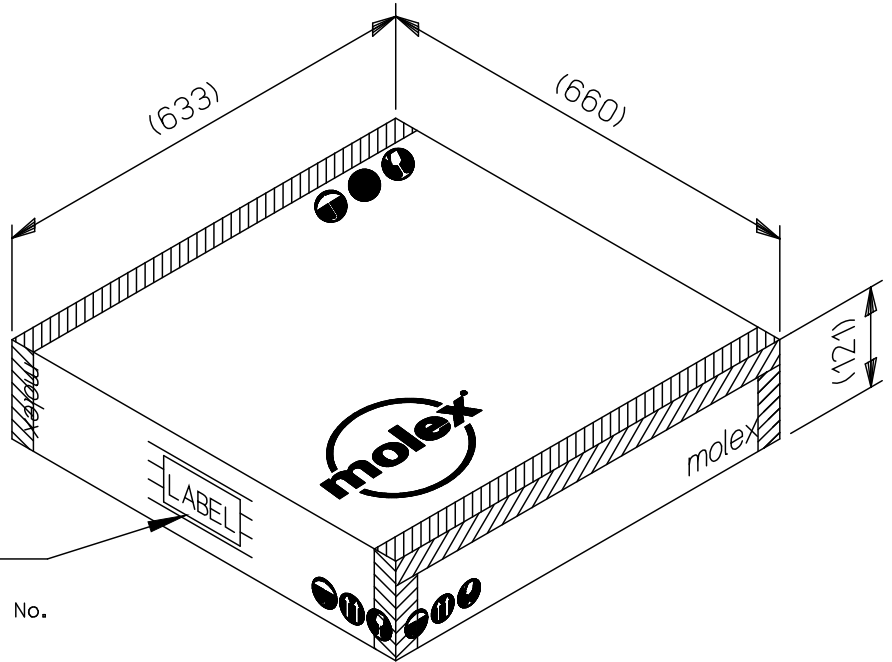

カートンラベル
CARTON LABEL

(製品型番, 数量, ロットNO. 表示)
INDICATION OF PART No., QUANTITY, LOT No.

REVISE ON PC ONLY		TITLE:	
B	SEE SHEET 1 OF 3	50079 梱包仕様書 SALES PACKAGING SPEC. FOR 50079	
	REV.	DESCRIPTION	THIS DOCUMENT CONTAINS INFORMATION THAT IS PROPRIETARY TO MOLEX INC. AND SHOULD NOT BE USED WITHOUT WRITTEN PERMISSION
DOCUMENT NUMBER SPK-50079-001		FILE NAME SPK50079001.docx	SHEET 2 OF 3
EN-037(2013-04 rev.1)			

2. 50079-8100 梱包仕様
PACKAGING SPECIFICATION

2-1. 製品名称 / PRODUCT NAME : 1.25 WIRE TO BOARD CONN. CRIMP RECEPTACLE TERMINAL
製品番号 / PART NUMBER : 50079-8100

2-2. 標準梱包数 / STANDARD PACKAGING QUANTITY

ポリ袋 POLY BAG	内装カートン PRIMARY CARTON		外装カートン SHIPPING CARTON
1袋中の製品数 QUANTITY IN ONE BAG	ポリ袋の数 NUMBER OF POLY BAG	製品数 QUANTITY	製品数(内装カートン×3) QUANTITY (PRIMARY CARTON X3)
1,000	25	25,000	75,000

2-3. カートン外形参考寸法 / CARTON OUTER DIMENSIONS (REFERENCE PURPOSE ONLY) 単位 / UNIT: mm

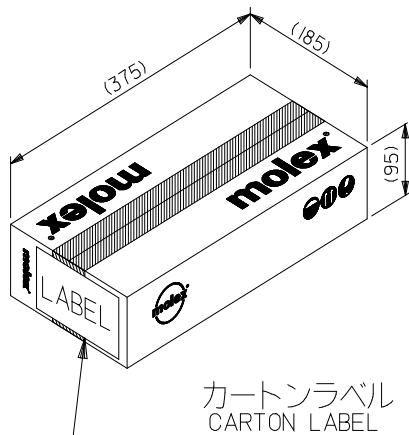

カートンラベル
CARTON LABEL
(製品型番, 数量, ロットNO. 表示)
INDICATION OF PART No., QUANTITY, LOT No.

内装カートン
PRIMARY CARTON

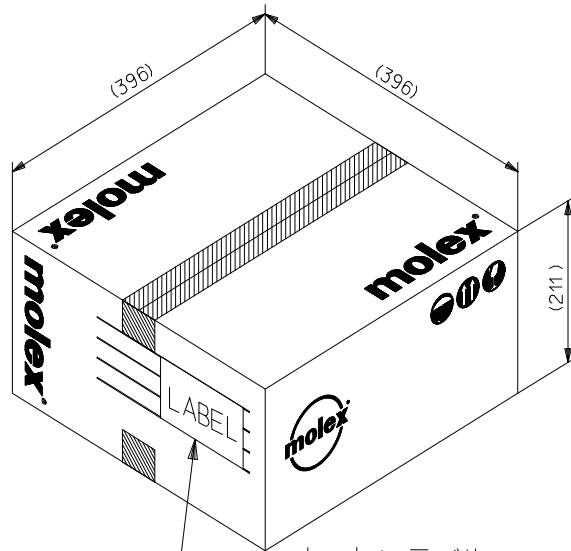

カートンラベル
CARTON LABEL
(製品型番, 数量, ロットNO. 表示)
INDICATION OF PART No., QUANTITY, LOT No.

外装カートン
SHIPPING CARTON

REVISE ON PC ONLY		TITLE:	
B	SEE SHEET 1 OF 3	50079 梱包仕様書 SALES PACKAGING SPEC. FOR 50079	
	REV.	DESCRIPTION	THIS DOCUMENT CONTAINS INFORMATION THAT IS PROPRIETARY TO MOLEX INC. AND SHOULD NOT BE USED WITHOUT WRITTEN PERMISSION
DOCUMENT NUMBER SPK-50079-001		FILE NAME SPK50079001.docx	SHEET 3 OF 3