

【1. 適用範囲 SCOPE】

本仕様書は、

1.25mm PITCH WIRE TO BOARD CONN. RECEPTACLE CRIMP TERM の圧着に伴う諸元について規定する。

THIS STANDARD SPECIFIES THE DIMENSIONS AFTER CRIMPING OF THE 1.25mm PITCH WIRE TO BOARD CONNECTOR REC. TERMINAL.

【2. 適用端子／電線 APPLICABLE TERMINAL／WIRE】

端子型番 Part Number	適用電線 WIRE SIZE		絶縁被覆外径 INSULATION DIAMETER
	AWG	mm ²	
50058-8025	#28-#32	0.031~0.086	φ1.0 MAX.
50079-8025	#26-#28	0.079~0.136	φ1.04 MAX.

【3. 各部の名称 DEFINITION】

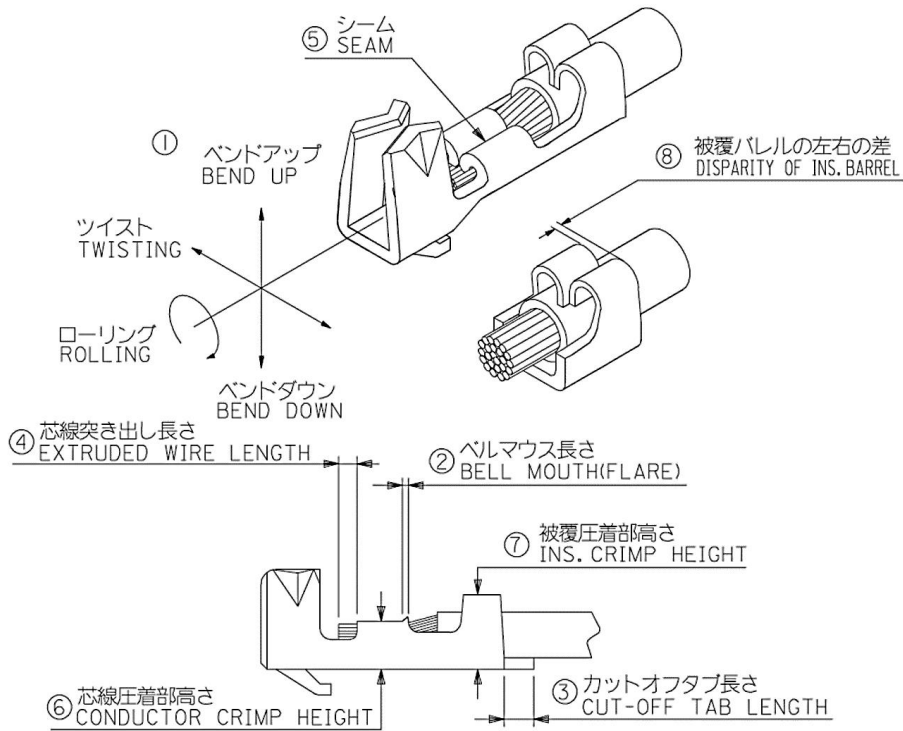

REV.	A	B				
SHEET	1-5	1-5				
REVISE ON PC ONLY			TITLE:			
B	変更 REVISED 611272 2019/01/30 S.OBARA		PicoBlade 1.25 RECEPTACLE CRIMP TERMINAL 0.38μm GOLD PLATING TYPE			
	DESCRIPTION		THIS DOCUMENT CONTAINS INFORMATION THAT IS PROPRIETARY TO MOLEX ELECTRONIC TECHNOLOGIES, LLC AND SHOULD NOT BE USED WITHOUT WRITTEN PERMISSION			
DESIGN CONTROL	STATUS		WRITTEN BY: SOBARA01	CHECKED BY: A.IDA	APPROVED BY: T.KANEKO	DATE: 2018/02/02
J						
DOCUMENT NUMBER 500580001-CS			DOC. TYPE PS	DOC. PART 000	CUSTOMER GENERAL	SHEET 1 OF 5

【4. 仕様 SPECIFICATION】

番号 NUMBER	項目 ITEM	仕様 REQUIREMENT
①	バンドアップ BEND UP	5°以下 / MAX.
	バンドダウン BEND DOWN	4°以下 / MAX.
	ツイスト TWISTING	6°以下 / MAX.
	ローリング ROLLING	8°以下 / MAX.
②	ベルマウス BELL MOUTH	0.05~0.3mm
③	カットオフタブ長さ CUT OFF TAB LENGTH	0.1mm以下 / MAX.
④	芯線突き出し長さ EXTRUDED WIRE LENGTH	0~0.7mm
⑤	シーム SEAM	シームは閉じていること。但し開きのある場合は芯線の飛び出しなきこと。 SEAM SHALL NOT BE OPENED AND NOT WIRE ALLOWED OUT OF CRIMPING THE AREA.
⑥	芯線圧着部高さ CONDUCTOR CRIMP HEIGHT	第5項参照 REFER TO 5 TH TERM
⑦	被覆圧着部高さ INS. CRIMP HEIGHT	第5項参照 REFER TO 5 TH TERM
⑧	被覆バレルの左右の差 DISPARITY OF INS. BARREL	0.2mm以下 / MAX.
≠	絶縁被覆むき長さ (参考値) WIRE STRIP LENGTH (REF.)	1.4~1.9mm
≠	絶縁被覆むき後の処理 (参考値) TREATMENT STRIPED WIRE (REF.)	芯線1本の外径がφ0.08mm未満の場合は、芯線を撚ること。 INCASE OF A CORE DIA. LESS φ0.08mm, CORE WIRE SHOULD BE TWISTED SLIGHTLY BEFORE CRIMPING.

REVISE ON PC ONLY		TITLE: PicoBlade 1.25 RECEPTACLE CRIMP TERMINAL 0.38μm GOLD PLATING TYPE
B	SEE SHEET 1 OF 5	
REV.	DESCRIPTION	THIS DOCUMENT CONTAINS INFORMATION THAT IS PROPRIETARY TO MOLEX ELECTRONIC TECHNOLOGIES, LLC AND SHOULD NOT BE USED WITHOUT WRITTEN PERMISSION

DOCUMENT NUMBER 500580001-CS	DOC. TYPE PS	DOC. PART 000	CUSTOMER GENERAL	SHEET 2 OF 5
---------------------------------	-----------------	------------------	---------------------	-----------------

【5. 圧着条件（⑥及び⑦） CONDITIONS】
5-1. 50058-8025

適用電線範囲の燃線（UL1571相当）を圧着した際の要件は下記による。

 AFTER CRIMPING THE WIRE（EQUIVALENT TO UL1571）,
THE CRIMPED AREAS SHOULD BE AS FOLLOWS.

ターミナル 番号 TERMINAL NO.	電線サイズ WIRE SIZE (AWG)	圧着 ツール番号 CRIMP DIE MODEL NO.	⑥芯線圧着部高さ CONDUCTOR CRIMP HEIGHT	⑦被覆圧着部 INSULATION	圧着部引張強度 CRIMP STRENGTH (N {Kgf})
			高さ HEIGHT (mm)	参考高さ HEIGHT (REF.) (mm)	
50058 —8025	#28	50767 —3710	0.49~0.45	1.2	9.8{1.0}以上 / MIN.
	#30		0.48~0.44		4.9{0.5}以上 / MIN.
	#32		0.47~0.43		3.4{0.3}以上 / MIN.

5-2. 50079-8025

適用電線範囲の燃線（UL1571相当）を圧着した際の要件は下記による。

 AFTER CRIMPING THE WIRE（EQUIVALENT TO UL1571）,
THE CRIMPED AREAS SHOULD BE AS FOLLOWS.

ターミナル 番号 TERMINAL NO.	電線サイズ WIRE SIZE (AWG)	圧着 ツール番号 CRIMP DIE MODEL NO.	⑥芯線圧着部高さ CONDUCTOR CRIMP HEIGHT	⑦被覆圧着部 INSULATION	圧着部引張強度 CRIMP STRENGTH (N {Kgf})
			高さ HEIGHT (mm)	参考高さ HEIGHT (REF.) (mm)	
50079 —8025	#26	57067 —3*00	0.60~0.65	1.2	19.6{2.0}以上 / MIN.
	#28		0.56~0.61		9.8{1.0}以上 / MIN.

REVISE ON PC ONLY

B

SEE SHEET 1 OF 5

TITLE:

**PicoBlade 1.25
RECEPTACLE CRIMP TERMINAL
0.38µm GOLD PLATING TYPE**

 THIS DOCUMENT CONTAINS INFORMATION THAT IS PROPRIETARY TO MOLEX ELECTRONIC
TECHNOLOGIES, LLC AND SHOULD NOT BE USED WITHOUT WRITTEN PERMISSION

REV.

DESCRIPTION

DOCUMENT NUMBER

500580001-CS

DOC. TYPE

PS

DOC. PART

000

 CUSTOMER
GENERAL

SHEET

3 OF 5

被覆圧着形状について

本圧着ターミナルはコネクタの小型化のために、被覆圧着部の各寸法がターミナルの板厚に比べ小さい事と、被覆バレルが電線の被覆部を突き破る圧着形状を避けるために、被覆バレル内側にコイニング加工している事で、被覆バレル先端は第1図のように種々の圧着形状が発生します。また、電線の外径が細径（φ0.7以下）の場合、被覆バレルの先端が電線に触れない形状になることもあります。これらの圧着形状は電線、被覆圧着パンチ、ターミナル等のわずかな変化で、変わる場合があります。いずれの圧着形状も被覆圧着部の本来の機能を満たし、しかも悪影響のない事を確認しています。

INSULATION CRIMP FORM

This crimp terminal is designed for miniaturization, therefore, each dimension of insulation crimp portion is small as compared with the terminal material thickness, and in order to avoid insulation piercing crimp form by the insulation barrel, coining is provided inside of the insulation barrel, accordingly various crimp forms are occurred at the tip of the insulation crimp barrel, as shown in the fig. 1.

In case of the wire dia. is small (φ0.7 MAX.), the tip of crimp barrel may not touch the wire.

These crimp forms may be changed comply with a little change of wire, insulation crimp punch and terminal.

The crimp forms, in any case, are satisfactory for the original function of the insulation crimp portion and it is confirmed that is no bad influence.

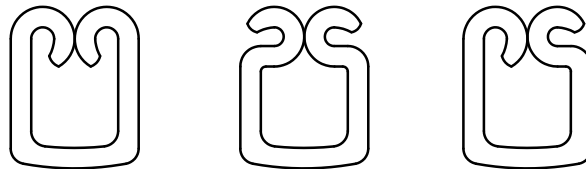

第1図
FIG.1

【6. 消耗部品一覧表 PERISHABLE PARTS LIST】

6-1. 50058-8025

部品名称 PART NAME	部品番号 PART NO.
圧着機 CRIMP MACHINE	57067-3710
アンビル ANVIL	57067-2421
芯線クリンプパンチ COND. PUNCH	57067-2422
被覆クリンプパンチ INS. PUNCH	57067-2403
フロントフローティングシェア FRONT FLOTING SHEAR	578001-2408
フロントホルダー FRONT HOLDER	578001-2414

6-2. 50079-8025

部品名称 PART NAME	部品番号 PART NO.	
圧着機 CRIMP MACHINE	57067-3000	57067-3700
アンビル ANVIL	57067-2001	57067-2401
芯線クリンプパンチ COND. PUNCH	57067-2002	57067-2402
被覆クリンプパンチ INS. PUNCH	57067-2003	57067-2403
フロントフローティングシェア FRONT FLOTING SHEAR	57067-2006	578001-2408
フロントホルダー FRONT HOLDER	57067-2005	578001-2414

B	REVISE ON PC ONLY	TITLE: PicoBlade 1.25 RECEPTACLE CRIMP TERMINAL 0.38μm GOLD PLATING TYPE			
	SEE SHEET 1 OF 5				
REV.	DESCRIPTION	THIS DOCUMENT CONTAINS INFORMATION THAT IS PROPRIETARY TO MOLEX ELECTRONIC TECHNOLOGIES, LLC AND SHOULD NOT BE USED WITHOUT WRITTEN PERMISSION			
DOCUMENT NUMBER 500580001-CS		DOC. TYPE PS	DOC. PART 000	CUSTOMER GENERAL	SHEET 4 OF 5

REV.	REV. RECORD	DATE	EC NO.	WRITTEN BY :	CHECKED BY :
A	RELEASED	2018/10/29	606400	S.OBARA	A.IDA
B	REVISED	2018/01/30	611272	S.OBARA	A.IDA

REVISE ON PC ONLY		TITLE:
B	SEE SHEET 1 OF 5	PicoBlade 1.25 RECEPTACLE CRIMP TERMINAL 0.38μm GOLD PLATING TYPE
REV.	DESCRIPTION	<small>THIS DOCUMENT CONTAINS INFORMATION THAT IS PROPRIETARY TO MOLEX ELECTRONIC TECHNOLOGIES, LLC AND SHOULD NOT BE USED WITHOUT WRITTEN PERMISSION</small>

DOCUMENT NUMBER 500580001-CS	DOC. TYPE PS	DOC. PART 000	CUSTOMER GENERAL	SHEET 5 OF 5
--	------------------------	-------------------------	----------------------------	-----------------