

1. 製品名称 / PRODUCT NAME : 1.25 WIRE TO BOARD WAFER ASSY R/A FOR SMT
EMBOSSSED TAPE PACKAGING

製品番号 / PART NUMBER : 5 3 2 6 1 - * * 2 7
5 3 2 6 1 - * * 7 1
5 3 2 6 1 - 7 0 * *
5 3 2 6 1 - * * 5 0
5 3 2 6 1 - 8 4 * *
5 3 2 6 1 - 8 6 * *

Use for Japan production only.

(* * は極数を示す)
(* * SHOWS CIRCUITS SIZE)

2. 標準梱包数 / STANDARD PACKAGING QUANTITY

極数 CKT. SIZE	キャリア テープ幅 (mm) CARRIER TAPE WIDTH (mm)	1 リール中の製品数 QTY. PER REEL	外装カートン SHIPPING CARTON	
			梱包リール数 NUMBER OF REELS	製品数 QUANTITY
2	16	1,000	8	8,000
3				
4				
5	24	1,000	6	6,000
6				
7				
8				
9				
10	32	1,000	4	4,000
11				
12				
13	44	1,000	3	3,000
14				
15				
17				

PENDING
APPROVAL

REV.	F				
SHEET	1~3				
REVISE ON PC ONLY		TITLE:			
F	REVISED 601118 2018/06/07 GSHARMA		5 3 2 6 1 梱包仕様書 SALES PACKAGING SPEC. FOR 53261		
	THIS DOCUMENT CONTAINS INFORMATION THAT IS PROPRIETARY TO MOLEX ELECTRONIC TECHNOLOGIES, LLC AND SHOULD NOT BE USED WITHOUT WRITTEN PERMISSION				
REV.	DESCRIPTION				
DESIGN CONTROL J		STATUS	WRITTEN BY: YTOKUZONO	CHECKED BY: T.HARUYAMA	APPROVED BY: N.UKITA
DOCUMENT NUMBER SPK-53261-002		DOC. TYPE PS	DOC. PART 001	CUSTOMER GENERAL	
				DATE: 2009/06/30	
				SHEET 1 OF 3	

3. ハイバリア袋への梱包方法及びラベル貼付位置/PACKAGING METHOD FOR HIGH BARRIER BAG AND LABEL POSITION.

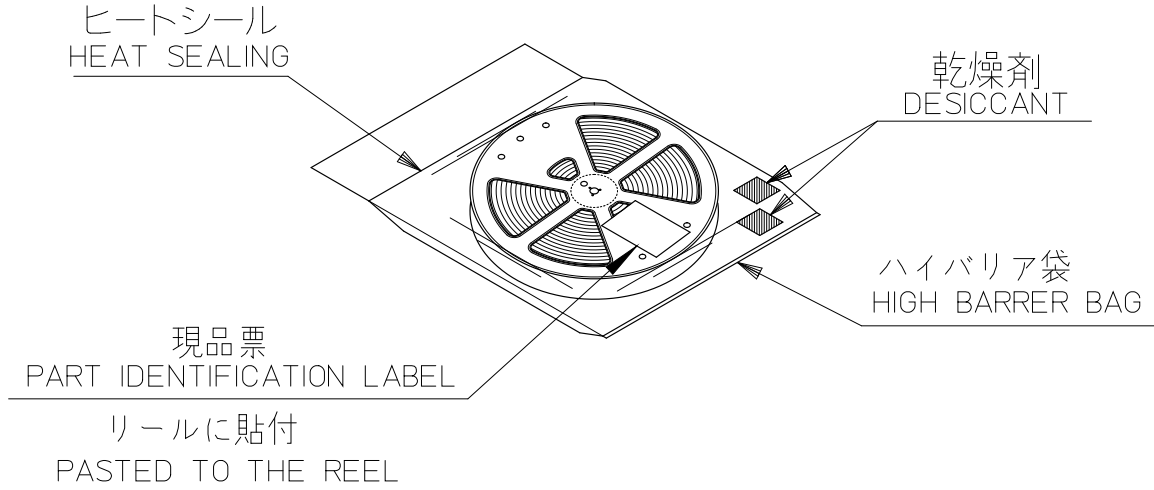

4. カートン外形参考寸法/CARTON OUTER DIMENSIONS (REFERENCE PURPOSE ONLY)

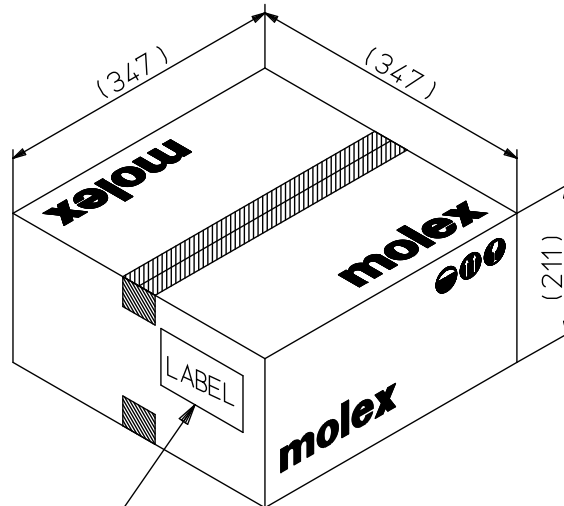

カートンラベル
CARTON LABEL

(製品型番, 数量, ロットNO. 表示)
INDICATION OF PART No., QUANTITY, LOT No.

標準カートン
STANDARD CARTON

PENDING APPROVAL

REVISE ON PC ONLY		TITLE:		
F	SEE SHEET 1 OF 3	5 3 2 6 1 梱包仕様書 SALES PACKAGING SPEC. FOR 53261		
REV.	DESCRIPTION	THIS DOCUMENT CONTAINS INFORMATION THAT IS PROPRIETARY TO MOLEX ELECTRONIC TECHNOLOGIES, LLC AND SHOULD NOT BE USED WITHOUT WRITTEN PERMISSION		
DOCUMENT NUMBER SPK-53261-002		DOC. TYPE PS	DOC. PART 001	CUSTOMER GENERAL
				SHEET 2 OF 3

Use for Korean production only.

1-1 제품 명칭(PRODUCT NAME) : 1.25 W/B CONN. WAFER ASSY EMBSTP PKG
제품 번호(PART NUMBER): 53261-71 (** SHOWS CIRCUITS SIZE)**

1-2 표준 포장 수량(PACKING QUANTITY):

CKT. SIZE	CARRIER TAPE WIDTH (mm)	QTY. PER REEL	SHIPPING CARTON		HIGH BARRIER BAG SIZE (mm)	MOUNT OF DESICCANT
			NUMBER OF REEL	QUANTITY		SILCAGEL
2	16	1,000	7	7,000	400 X 460 X 0.06	1
3	16	1,000	7	7,000	400 X 460 X 0.06	1
4	24	1,000	6	6,000	400 X 460 X 0.06	1
5	24	1,000	6	6,000	400 X 460 X 0.06	1
6	24	1,000	6	6,000	400 X 460 X 0.06	1
7	24	1,000	6	6,000	400 X 460 X 0.06	1
8	24	1,000	6	6,000	400 X 460 X 0.06	1
9	24	1,000	6	6,000	400 X 460 X 0.06	1
10	32	1,000	5	5,000	400 X 460 X 0.06	1
11	32	1,000	5	5,000	400 X 460 X 0.06	1
12	32	1,000	5	5,000	400 X 460 X 0.06	1
13	32	1,000	5	5,000	400 X 460 X 0.06	1
14	44	1,000	4	4,000	450 X 510 X 0.06	1
15	44	1,000	4	4,000	450 X 510 X 0.06	1

4. NOTE

- 포장 평가는 ES40000-7001에 따르고, LEVEL 2 기준을 적용한다.
 (ESTIMATE: APPLIED TO ES-40000-7001 AND LEVEL 2, CRITERION 1)

REVISE ON PC ONLY	
F	SEE SHEET 1 OF 3
REV.	DESCRIPTION

TITLE: 5 3 2 6 1 梱包仕様書 SALES PACKAGING SPEC. FOR 53261
THIS DOCUMENT CONTAINS INFORMATION THAT IS PROPRIETARY TO MOLEX ELECTRONIC TECHNOLOGIES, LLC AND SHOULD NOT BE USED WITHOUT WRITTEN PERMISSION

DOCUMENT NUMBER SPK-53261-002	DOC. TYPE PS	DOC. PART 001	CUSTOMER GENERAL	SHEET 3 OF 3
---	------------------------	-------------------------	----------------------------	-----------------