

REVISIONS				
EC NO	DATE	REV	DESCRIPTION	CHANGER
	2018/12/20	A	INITIAL RELEASE	DLI50
NA	2019/01/18	A2	ADD PACKING METHOD 6	DLI50
NA	2019/03/05	B	UPDATE PACKAGE METHOD PER ACTUAL PACKAGE	DLI50
NA	2019/05/16	C	CHANGE SPQ FROM 80 TO 100	DLI50
NA	2019/05/23	C1	CHANGE PACKING METHOD	DLI50

Packing method:

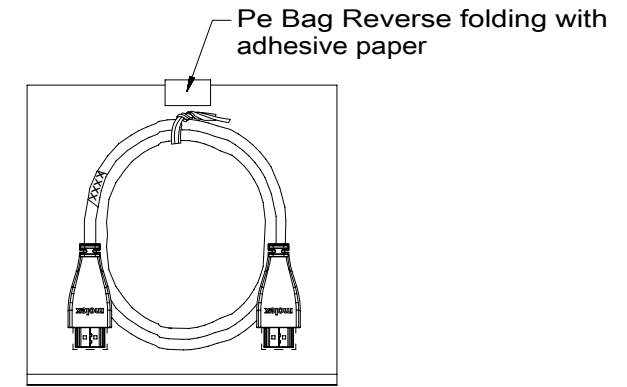
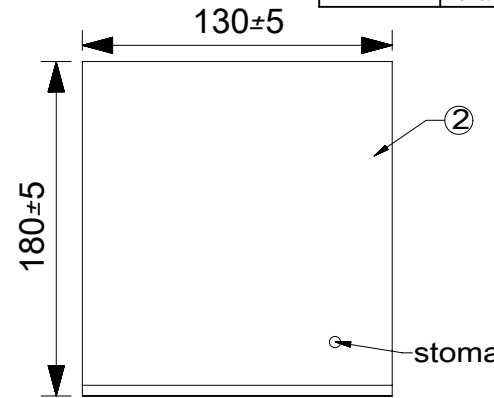
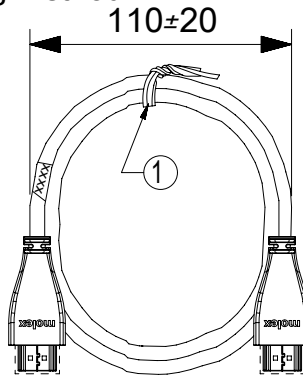

Winding coil: top 3 coils and bottom 2 coils PE BAG: L180*W130*T0.08mm

Packing method:

1. Install the tested product with dust cover, as shown above, and wrap it well. Line products are packed in PE bags and sealed by heat.
2. Put a waterproof bag and a partition in the box first, and put the products in order.
3. Seal the box with sealing tape in I-shape.
4. Fill in the front/side of the carton completely. (e.g. quantity, LOT NO., box number, etc.).
5. STICK UL LABEL ON CARTON.

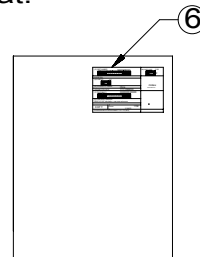

Side

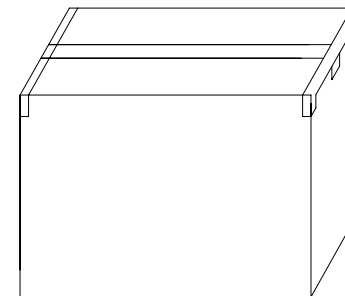

Positive

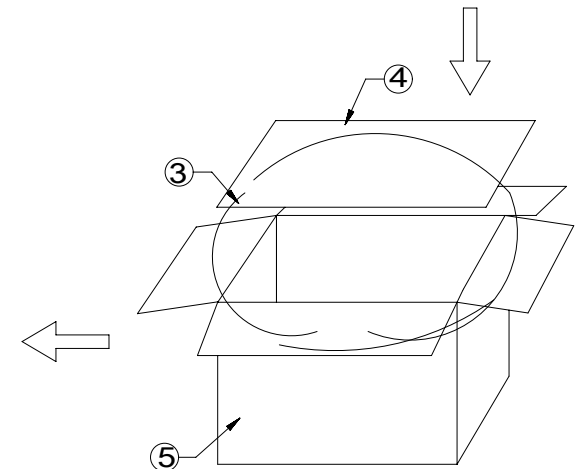

6	LABEL	LABEL	A/R	SYMBOLS
5	Carton	L385 * W285 * H265mm (K=K) Printed Adhesive Method	A/R	▽ = 0
4	Cardboard	L368*W270*H3mm,B33	A/R	▽ = 0
3	Pe Bag	L915 * W813 * T0.04mm (760mm is the opening side)	A/R	▽ = 0
2	Pe Bag	L180 * W130 * T0.08mm	1	▽ = 0
1	Tie band	Elliptical PE, black cored bandage	A/R	▽ = 0
ITEM	PART NAME	SPEC DESCRIPTION	Q'TY	▽ = 0

THIS DRAWING CONTAINS INFORMATION THAT IS PROPRIETARY TO MOLEX ELECTRONIC TECHNOLOGIES, LLC AND SHOULD NOT BE USED WITHOUT WRITTEN PERMISSION

DIMENSION UNITS	SCALE	CURRENT REV DESC:	molex		
mm	1:1				
GENERAL TOLERANCES (UNLESS SPECIFIED)			HDMI TO HDMI A 1.4 WITH ETHERNET L=1M		
ANGULAR TOL	± °	EC NO: 617821	PACKAGING DESIGN DRAWING		
4 PLACES	±	DRWN: ZYLI02 2019/05/23	DOCUMENT NUMBER		
3 PLACES	±	CHK'D: ZYLI02 2019/05/23	687670199		
2 PLACES	±	APPR: CLAN01 2019/05/23	DOC TYPE DOC PART REVISION		
1 PLACE	±	INITIAL REVISION:	PDD PK C1		
0 PLACES	±	DRWN: DLI50 2018/12/20	MATERIAL NUMBER		
□ = 0		APPR: CLAN01 2018/12/21	687670199		
■ = 0		DRAFT WHERE APPLICABLE MUST REMAIN WITHIN DIMENSIONS	CUSTOMER		
▽ = 0		THIRD ANGLE PROJECTION	SHEET NUMBER		
		DRAWING	1 OF 1		
		SERIES	A4-SIZE 68767		

DOCUMENT STATUS	P1	RELEASE DATE	2019/05/23	10:24:01
-----------------	----	--------------	------------	----------