

OPTION "E"

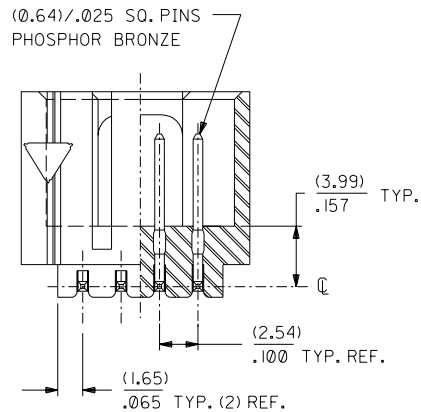

SECTION E-E

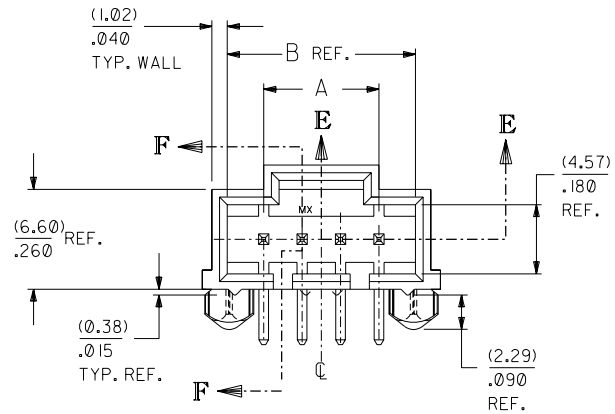
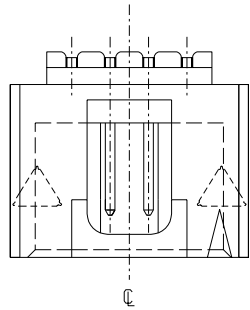
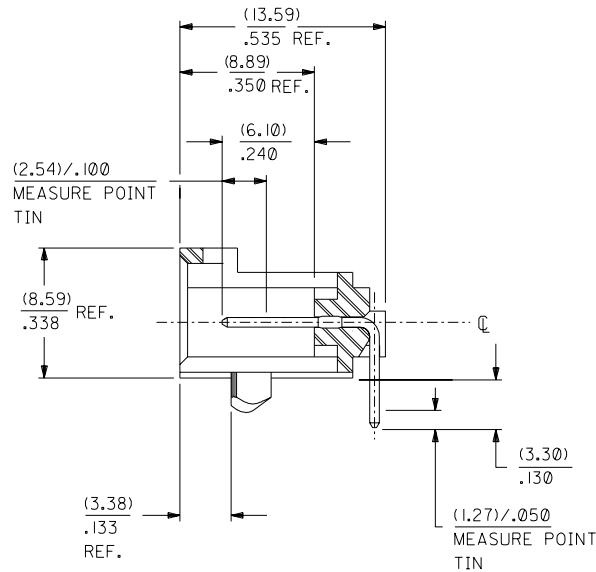

SECTION F-F

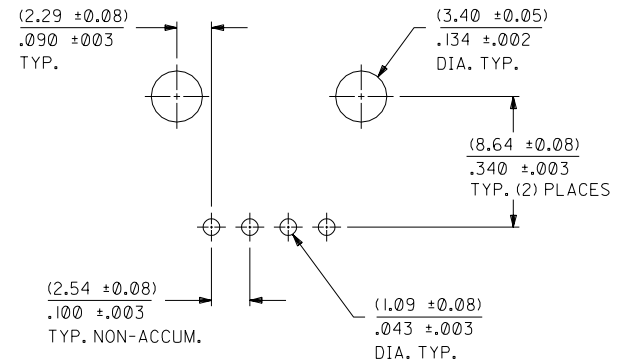

RECOMMENDED P.C. BOARD LAYOUT

(FOR USE WITH (1.57) / .062 THICK BOARD)

- THE PRIMARY SHIPPING CARTON WILL BE LABELED "COMPLIANT TO ROHS DIRECTIVE 2002/95/EC AND ELV ANNEX II OF DIRECTIVE 2000/53/EC". CARTONS WITHOUT THIS LABEL MAY CONTAIN PRODUCT WITH LEAD. PLATING PER E.S.-88-****

- TIN - .000150 MINIMUM TIN PLATE OVER .000050 MINIMUM NICKEL PLATE.
- 15 GOLD - .000015 MINIMUM GOLD PLATE IN SELECT AREA, .000075 MINIMUM TIN PLATE IN SELECT AREA, OVER .000050 MINIMUM NICKEL PLATE OVERALL.
- 30 GOLD - .000030 MINIMUM GOLD PLATE IN SELECT AREA, .000075 MINIMUM TIN PLATE IN SELECT AREA, OVER .000050 MINIMUM NICKEL PLATE OVERALL.

(SEE SH.2 FOR OPTIONAL PLATINGS)

NOTES

- 1) MATERIAL: G.F. THERMOPLASTIC, 94V-0, COLOR-BLACK.
- 2) HEADER TO BE USED WITH NO. 70004 INTERIM CLIP, VERSION "A".
- 3) REFER TO PRODUCT SPEC: P.S.-7054I.
- 4) STANDARD PACKAGING PER PK-70873-0017. OPTIONAL PACKAGING MAY BE AVAILABLE. (SEE DRAWING PK-70575-**** FOR ORDER NUMBERS)

CKT. SIZE	"A"		"B" REF.	
	MM	IN.	MM	IN.
4	7.62	.300	12.45	.490
5	10.16	.400	14.99	.590
6	12.70	.500	17.53	.690
7	15.24	.600	20.07	.790
8	17.78	.700	22.61	.890
9	20.32	.800	25.15	.990
10	22.86	.900	27.69	1.090
11	25.40	1.000	30.23	1.190
12	27.94	1.100	32.77	1.290
13	30.48	1.200	35.31	1.390
14	33.02	1.300	37.85	1.490
15	35.56	1.400	40.39	1.590
16	38.10	1.500	42.93	1.690
17	40.64	1.600	45.47	1.790
18	43.18	1.700	48.01	1.890
19	45.72	1.800	50.55	1.990
20	48.26	1.900	53.09	2.090
21	50.80	2.000	55.63	2.190
22	53.34	2.100	58.17	2.290
23	55.88	2.200	60.71	2.390
24	58.42	2.300	63.25	2.490
25	60.96	2.400	65.79	2.590

DIMENSIONS SHOWN (METRIC) INCH UNLESS OTHERWISE SPECIFIED TOLERANCES: ANGULAR ± 1/2°		▽ = 0 ▼ = 0 REVISE ONLY ON CAD SYSTEM	
INCH METRIC		TITLE	
3 PLACE ± .010	---	SALES ASSEMBLY HEADER - RIGHT ANGLE	
2 PLACE ± .014	± 0.25	.100 CENTERS W/P.C.B. PEGS	
1 PLACE ---	± 0.35	MOLEX INCORPORATED	
DRAFT WHERE APPLICABLE MUST REMAIN WITHIN DIMENSIONS		SHEET NO. DATE	
PART NO. DRWG. NO.		1 OF 2 05/13/93	
FILE NAME		SDA-70575-****	
APP'D. BY		THIS DRAWING CONTAINS INFORMATION THAT IS PROPRIETARY TO MOLEX INC. AND SHOULD NOT BE USED WITHOUT WRITTEN PERMISSION.	
SCALE		DA C	

LTR.	REVISIONS	LTR.	REVISIONS
	B		A
	LEAD FREE UCP2004-1769 RWHITE 04/03/31		RELEASED U30638 5/13/93 MGB

	13	12	11	10	9	8	7	6	5	4	3	2	1
	ENGINEERING NUMBER A-70575-	MANUFACTURE RELEASE STATUS								CONNECTOR END PLATING	P.C. BOARD END PLATING		
										TYPE	H MEAS.	TYPE	K MEAS.
J	-0003-0024	R.F.M.								TIN	(2,54) .100	TIN	(1,27) .050
	-0038-0059	R.F.M.								15 GOLD	(2,54) .100	TIN	(1,27) .050
I	-0073-0094	R.F.M.								30 GOLD	(2,54) .100	TIN	(1,27) .050
	-0108-0129												
	-0143-0164	R.F.M.								50 GOLD	(2,54) .100	TIN	(1,27) .050
H													

	CKTS	EDP NUMBER	ENG NUMBER	EDP NUMBER	ENG NUMBER	EDP NUMBER	ENG NUMBER	EDP NUMBER	ENG NUMBER	EDP NUMBER	ENG NUMBER	EDP NUMBER	ENG NUMBER	EDP NUMBER	ENG NUMBER	CKTS
	02	N.A.	N.A.	N.A.	N.A.	N.A.	N.A.	N.A.	N.A.	N.A.	N.A.	N.A.	N.A.	N.A.	N.A.	02
	03	N.A.	N.A.	N.A.	N.A.	N.A.	N.A.	N.A.	N.A.	N.A.	N.A.	N.A.	N.A.	N.A.	N.A.	03
	04	705-75-0003	A-70575-0003	705-75-0038	A-70575-0038	705-75-0073	A-70575-0073		A-70575-0108	705-75-0143	A-70575-0143					04
	05	705-75-0004	A-70575-0004	705-75-0039	A-70575-0039	705-75-0074	A-70575-0074		A-70575-0109	705-75-0144	A-70575-0144					05
	06	705-75-0005	A-70575-0005	705-75-0040	A-70575-0040	705-75-0075	A-70575-0075		A-70575-0110	705-75-0145	A-70575-0145					06
F	07	705-75-0006	A-70575-0006	705-75-0041	A-70575-0041	705-75-0076	A-70575-0076		A-70575-0111	705-75-0146	A-70575-0146					07
	08	705-75-0007	A-70575-0007	705-75-0042	A-70575-0042	705-75-0077	A-70575-0077		A-70575-0112	705-75-0147	A-70575-0147					08
	09	705-75-0008	A-70575-0008	705-75-0043	A-70575-0043	705-75-0078	A-70575-0078		A-70575-0113	705-75-0148	A-70575-0148					09
	10	705-75-0009	A-70575-0009	705-75-0044	A-70575-0044	705-75-0079	A-70575-0079		A-70575-0114	705-75-0149	A-70575-0149					10
	11	705-75-0010	A-70575-0010	705-75-0045	A-70575-0045	705-75-0080	A-70575-0080		A-70575-0115	705-75-0150	A-70575-0150					11
	12	705-75-0011	A-70575-0011	705-75-0046	A-70575-0046	705-75-0081	A-70575-0081		A-70575-0116	705-75-0151	A-70575-0151					12
	13	705-75-0012	A-70575-0012	705-75-0047	A-70575-0047	705-75-0082	A-70575-0082		A-70575-0117	705-75-0152	A-70575-0152					13
E	14	705-75-0013	A-70575-0013	705-75-0048	A-70575-0048	705-75-0083	A-70575-0083		A-70575-0118	705-75-0153	A-70575-0153					14
	15	705-75-0014	A-70575-0014	705-75-0049	A-70575-0049	705-75-0084	A-70575-0084		A-70575-0119	705-75-0154	A-70575-0154					15
	16	705-75-0015	A-70575-0015	705-75-0050	A-70575-0050	705-75-0085	A-70575-0085		A-70575-0120	705-75-0155	A-70575-0155					16
	17	705-75-0016	A-70575-0016	705-75-0051	A-70575-0051	705-75-0086	A-70575-0086		A-70575-0121	705-75-0156	A-70575-0156					17
	18	705-75-0017	A-70575-0017	705-75-0052	A-70575-0052	705-75-0087	A-70575-0087		A-70575-0122	705-75-0157	A-70575-0157					18
	19	705-75-0018	A-70575-0018	705-75-0053	A-70575-0053	705-75-0088	A-70575-0088		A-70575-0123	705-75-0158	A-70575-0158					19
D	20	705-75-0019	A-70575-0019	705-75-0054	A-70575-0054	705-75-0089	A-70575-0089		A-70575-0124	705-75-0159	A-70575-0159					20
	21	705-75-0020	A-70575-0020	705-75-0055	A-70575-0055	705-75-0090	A-70575-0090		A-70575-0125	705-75-0160	A-70575-0160					21
	22	705-75-0021	A-70575-0021	705-75-0056	A-70575-0056	705-75-0091	A-70575-0091		A-70575-0126	705-75-0161	A-70575-0161					22
	23	705-75-0022	A-70575-0022	705-75-0057	A-70575-0057	705-75-0092	A-70575-0092		A-70575-0127	705-75-0162	A-70575-0162					23
	24	705-75-0023	A-70575-0023	705-75-0058	A-70575-0058	705-75-0093	A-70575-0093		A-70575-0128	705-75-0163	A-70575-0163					24
	25	705-75-0024	A-70575-0024	705-75-0059	A-70575-0059	705-75-0094	A-70575-0094		A-70575-0129	705-75-0164	A-70575-0164					25

OPTIONAL PLATINGS
50 GOLD - .000050 MIN. GOLD IN SELECT AREA
.000075 MIN. TIN IN SELECT AREA
.000050 MIN. NICKEL PLATE OVER-ALL.

DIMENSIONS SHOWN (METRIC) INCH UNLESS OTHERWISE SPECIFIED TOLERANCES ANGULAR ± 1/2°		▽ = 0 ▽ = 0 REVISE ONLY ON CAD SYSTEM	
3 PLACE ± --- --- 2 PLACE ± --- ± --- 1 PLACE --- ± ---		TITLE SALES ASSEMBLY HEADER - RIGHT ANGLE 100 CENTERS W/P.C.B. PEGS	
DRAWING WHERE APPLICABLE MUST REMAIN WITHIN DIMENSIONS		MOLEX INCORPORATED LITSE,ILL. 60532 U.S.A. SHEET NO. 2 DATE 05/13/93	
DRWG. BY AAB CHK'D. BY AAB APP'D. BY WAZ SCALE :		PART NO. SEE CHART DRWG. NO. SDA-70575-****	
L.T.R. REVISIONS L.T.R. REVISIONS		FILE NAME 570575X2.DGN THIS DRAWING CONTAINS INFORMATION THAT IS PROPRIETARY TO MOLEX INC. AND SHOULD NOT BE USED WITHOUT WRITTEN PERMISSION DA C	