

ENGINEERING NO.	PART NO.	DESCRIPTION
71629-3000	71629-3000	INTERNAL THREADS
71629-4000	71629-4000	LEAD-IN COUNTERSINK

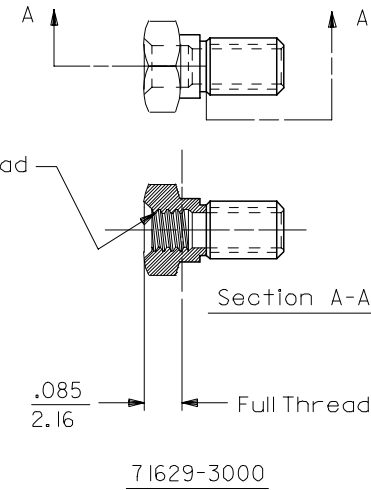

71629-4000:
Countersink .050 x 45°

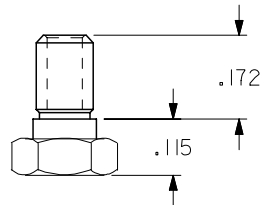
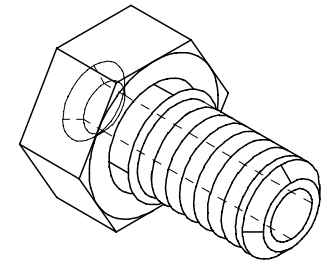
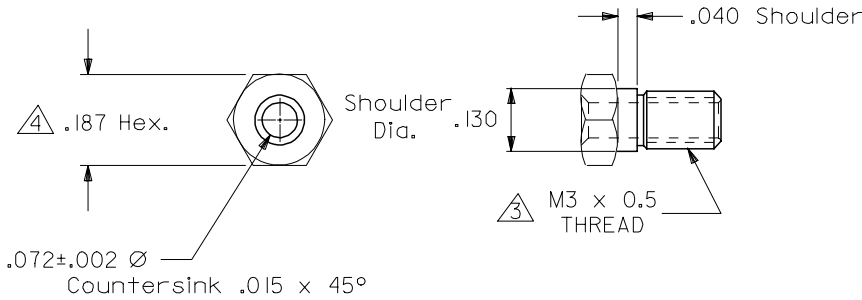
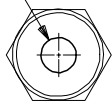

- NOTES:
1. MATERIAL: COLD DRAWN STEEL.
 2. FINISH: NICKEL PLATED.
 3. MAXIMUM APPLIED BODY TORQUE: 5 IN-LBS.
 4. SOCKET SIZE: 3/16 IN.
 5. TO BE BULK PACKED IN A BAG WITH A QUANTITY OF 500 PARTS PER BAG

ADD NOTE 5
EC NO: UCP2008-0088
DRAWN BY: DRWNMSIBARRA 2007/07/26
CHKD BY: CHKDPMORGAN 2007/08/06
APPR. BY: APPRSMILLER 2007/08/08

REV	DESCRIPTION
1	QUALITY SYMBOLS
2	▽=0
3	▽=0

GENERAL TOLERANCES (UNLESS SPECIFIED)	
mm	INCH
4 PLACES ± ---	± ---
3 PLACES ± ---	± .010
2 PLACES ± ---	± ---
1 PLACE ± ---	± ---
ANGULAR ±1/2°	

DIMENSION STYLE INCH ONLY	
DRAWN BY	DATE
MOS	1993/03/11
CHECKED BY	DATE
BIXLER	1993/03/11
APPROVED BY	DATE
BIXLER	1993/03/11

SCALE	DESIGN UNITS	THIRD ANGLE PROJECTION
4:1	INCH	☉
GUIDE SLEEVE LFH CONNECTOR SYSTEM		
MOLEX INCORPORATED		SHEET NO.
SDA-71629-***		1 OF 1

THIS DRAWING CONTAINS INFORMATION THAT IS PROPRIETARY TO MOLEX INCORPORATED AND SHOULD NOT BE USED WITHOUT WRITTEN PERMISSION