

71743

NOTES:

- 1) MATERIALS:
HOUSING- LIQUID CRYSTAL POLYMER (LCP), GLASS FILLED,
UL 94V-0, BLACK.
TERMINALS- COPPER ALLOY
ESD METAL PEGS- COPPER ALLOY.
- 2) PLATING OPTION 1:
TERMINALS:
.000030/(0.00076) MIN. GOLD IN CONTACT AREA AND
.000100/(0.00254) MIN. TIN-LEAD IN TAIL AREA OVER
NICKEL OVERALL.
ESD METAL PEGS:
.000150/(0.00381) MIN. TIN-LEAD OVER
NICKEL OVERALL.
- 3) PLATING OPTION 2:
TERMINALS:
GOLD FLASH IN SELECT CONTACT AREA OVER
.000030/(0.00076) MIN. PALLADIUM NICKEL IN CONTACT AREA AND
.000075/(0.00191) MIN. TIN-LEAD IN TAIL AREA OVER
NICKEL OVERALL.
ESD METAL PEGS:
.000150/(0.00381) MIN. TIN-LEAD OVER
NICKEL OVERALL.
- 4) CONFORMS TO PRODUCT SPECIFICATION PS-73826-0000.
- 5) CIRCUIT NUMBERS 1, 36 THRU 43, 45, 46, AND 75 THRU 80,
ARE ADVANCED (LONG) TERMINALS FOR SEQUENTIAL MATING.
- 6) CONNECTOR WILL ACCEPT MATING TO A P.C. BOARD WITH A
THICKNESS OF .062±.003 (1.60±0.08).
- 7) SEE TABLE FOR RECOMMENDED P.C. BOARD THICKNESS.
- 8) PRODUCT PACKAGED PER PK-70873-083*
- 9) FOUR DIGIT DATE CODE (WK, YR), EXAMPLE => 26 96
LOCATED IN AREA INDICATED.

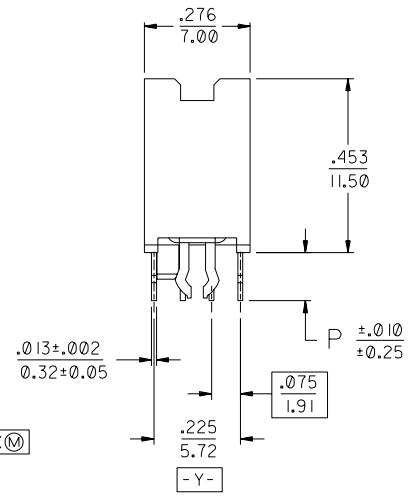
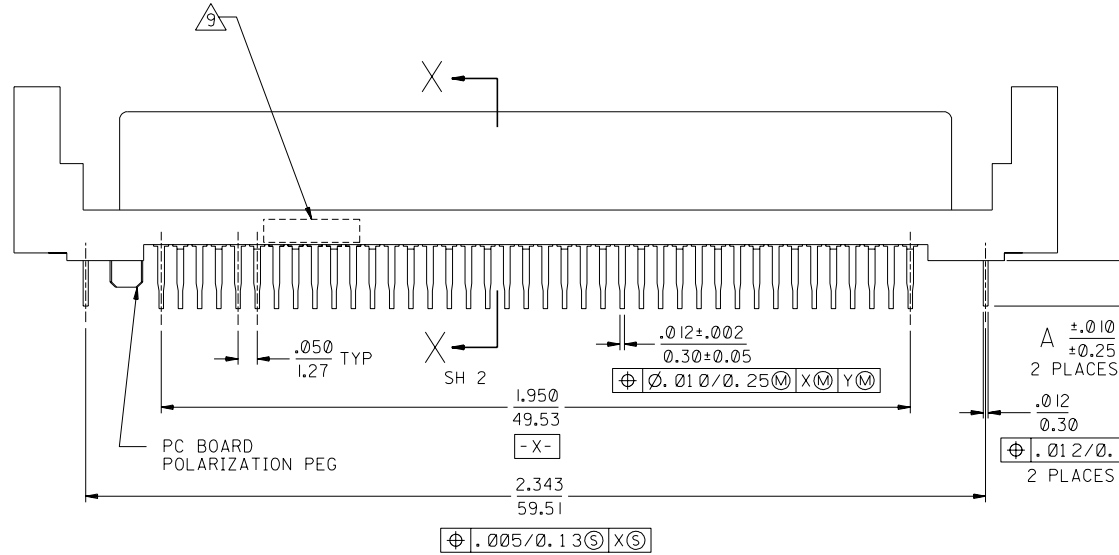
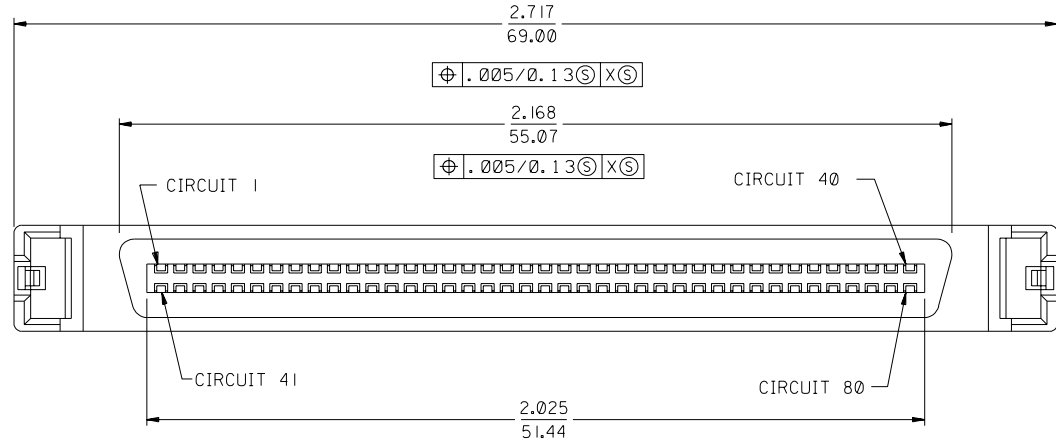

H	REVISD ECN UCP2003-0093 BBARKER 02/08/13
G	REVISD ECN UDT 2000-1231 ACHAMMER 00-06-07
F3	REVISD ECN UDT 1999-0975 ACHAMMER 99-05-11
F2	REVISD ECN UDT 1999-0865 ACHAMMER 99-04-09
F1	REVISD ECN UDT1998-0294 STANISLA 98-06-10
F	REVISD PER ECN U80654 ACHAMMER 97-9-18
E	REVISD PER ECN U71495 ACHAMMER 97-6-2
DI	REVISD PER ECN U70444 ACHAMMER 96-11-26
D	REVISD PER ECN U61278 5-2-96 DGA
C	REVISD PER ECN U61122 3-22-96 RAN
B	REVISD PER ECN U60641 11-29-95 DRS
A	INITIAL RELEASE PER ECN U60019 8-15-95 RAN

71743-1086	OBSOLETE			
71743-1085	SEE NOTE 2	.130±.006 (3.30±0.15)	.118 (3.00)	.148 (3.75)
71743-1084	SEE NOTE 2	.125±.006 (3.18±0.15)	.118 (3.00)	.134 (3.40)
71743-1083	SEE NOTE 2	.093±.006 (2.36±0.15)	.118 (3.00)	.125 (3.18)
71743-1082	OBSOLETE			
71743-1081	SEE NOTE 2	.062±.006 (1.60±0.15)	.118 (3.00)	.110 (2.79)
71743-1080	SEE NOTE 2	.093±.006 (2.36±0.15)	.118 (3.00)	.125 (3.18)
PART NUMBER	PLATING	PCB THICKNESS	DIM. A	DIM. P

SALES ASSEMBLY
EBBI VERTICAL RECEPTACLE
80 CKT SCA-2 CONNECTOR

MOLEX INCORPORATED
LITSE, ILL. 60532 U.S.A.

DATE: 7/21/95

SEE TABLE SDA-71743-108*

DRWG. NO. 4:1

