



PRODUCT SPECIFICATION

1.0 SCOPE

This Product Specification covers SMB FAKRA R/A PCB connector (P/N 73415-286* & 73415-291*)

2.0 PRODUCT DESCRIPTION

2.1 PRODUCT NAME

SMB FAKRA

3.0 APPLICABLE DOCUMENTS AND SPECIFICATIONS

4.0 RATINGS

4.1 VOLTAGE

335 Vrms at Sea Level
85 Vrms at 70,000 Feet

4.2 TEMPERATURE

Rating: - 55°C TO + 105°C

4.3 FREQUENCY RATING

0 to 4 GHz

4.4 NOMINAL IMPEDANCE

50 Ohms

REVISION: B2	ECR/ECN INFORMATION: EC No: URF2007-0123 DATE: 2006 / 04 / 10	TITLE: SMB FAKRA 50 OHM (73415-286* & 73415-291*)	SHEET No. 1 of 4
DOCUMENT NUMBER: PS-73598-0360	CREATED / REVISED BY: EVITA LIN	CHECKED BY: James Lin	APPROVED BY: Misen Huang



PRODUCT SPECIFICATION

5.0 PERFORMANCE

5.1 ELECTRICAL REQUIREMENTS

ITEM	DESCRIPTION	TEST CONDITION	REQUIREMENT
1	Insulation Resistance	MIL-PRF-39012, paragraph 3.11	5000 Megaohms
2	Dielectric Withstanding Voltage	MIL-PRF-39012, paragraph 3.17	750 Vrms
3	RF High Potential Withstanding	MIL-PRF-39012, paragraph 3.23	600 Vrms @ 5 MHz to 7.5 MHz
4	Contact Resistance	MIL-PRF-39012, paragraph 3.16 Center Contact Initial Center Contact After Environment Outer Contact Outer Cable Conductor to Body	6 Milliohms 8 Milliohms 2 Milliohms N/A
5	Voltage Standing Wave Ratio	MIL-PRF-39012, paragraph 3.14	1.3 Max. to 3 GHz
6	RF Leakage	MIL-PRF-39012, paragraph 3.26	-55 dB @ 1 GHz
7	RF Insertion Loss	MIL-PRF-39012, paragraph 3.27	.3 dB Max @ 3 GHz

5.2 MECHANICAL REQUIREMENTS

ITEM	DESCRIPTION	TEST CONDITION	REQUIREMENT
8	Material	MIL-PRF-39012, paragraph 3.3	See Sales Drawing
9	Finish	MIL-PRF-39012, paragraph 3.3.1	See Sales Drawing
10	Design	MIL-PRF-39012, paragraph 3.4	See Sales Drawing
11	Force to Engage and Disengage	Axial Force Radial Force	25 N (5.62 lbs) Max. N/A
12	Mating Angle/ Force	Mating pair. See Figure 1	180° ± 2° Force 25N M ax.
13	Shroud Retention Force		110 N (24.75 lbs)

REVISION: B2	ECR/ECN INFORMATION: EC No: URF2007-0123 DATE: 2006 / 04 / 10	TITLE: SMB FAKRA 50 OHM (73415-286* & 73415-291*)	SHEET No. 2 of 4
DOCUMENT NUMBER: PS-73598-0360	CREATED / REVISED BY: EVITA LIN	CHECKED BY: James Lin	APPROVED BY: Misen Huang



PRODUCT SPECIFICATION

5.2 MECHANICAL REQUIREMENTS (continued)

ITEM	DESCRIPTION	TEST CONDITION	REQUIREMENT
14	Connector Durability	MIL-PRF-39012, paragraph 3.15	100 Cycles
15	Center Contact Retention	MIL-PRF-39012, paragraph 3.12 Axial Force Radial Torque	17.8 N (4 lbs) N/A

5.3 ENVIRONMENTAL REQUIREMENTS

ITEM	DESCRIPTION	TEST CONDITION	REQUIREMENT
16	Vibration	10 HZ ~100HZ --- 2.0 G 100 Hz ~ 200HZ --- 1.0 G (DC 1 mA ; on exercise X , Y ,Z 5 mins/per cycle)	No Damage/No Discontinuities
		15 HZ ~ 100 HZ --- 4.4 G 100 HZ ~ 200 HZ --- 2.5 G (Non-operation; on exercise ±X, ±Y, ±Z 20mins/per cycle; Durability 5 hours)	No Damage
17	Shock	6 surfaces/ per cycle 1. 20G, impact 6 surfaces during operating 2. 100G, impact 6 surfaces during non-operating	No Damage/No Discontinuities
18	Shock (Thermal)	MIL-STD-202, Method 107 Test Condition B -55°C±3°C for 30 Minutes, +105±2°C for 30 Minutes, 500 Cycles, Room Temperature Exposure after Test for 1-2 Hours, Mated Connectors	No Damage
19	Continuous Operating Test	Initial to 100 Hours : Temp. 60°C	No Damage
20	Solderability	Dip & IR-Reflow: 260 °C ± 5°C / 10 Seconds	Visual: No Damage to insulator/Shroud material
21	Corrosion (Salt Spray)	MIL-STD-202, Method 101, Test Condition B 48 Hours at 35°C±3°C, expose to fog of 5±1% Sodium Chloride Salt Solution After exposure wash with deionized water, not warmer than 38°C for Five Minutes, Air Dry. Inspect for Damage	No Damage

REVISION: B2	ECR/ECN INFORMATION: EC No: URF2007-0123 DATE: 2006 / 04 / 10	TITLE: SMB FAKRA 50 OHM (73415-286* & 73415-291*)	SHEET No. 3 of 4
DOCUMENT NUMBER: PS-73598-0360	CREATED / REVISED BY: EVITA LIN	CHECKED BY: James Lin	APPROVED BY: Misen Huang



PRODUCT SPECIFICATION

22	High Humidity Exposure	60±2°C at 95±5% Humidity , 240 Hours 24 Hours at Room Temperature Mated Connectors	No Damage
23	Corona Level	MIL-PRF-39012, paragraph 3.22 At 70,000 Feet	250 Vrms
24	High Temperature Exposure	85±2°C for 100 Hours 1-2 hours Room Temperature	No Damage
25	Low Temperature Exposure	-40±3°C for 1000 Hours 1-2 Hours Room Temperature	No Damage
26	Repetitive Motion (1)	Initial Stage to 100 Hours: 60°C 10-200 Hours: 60°C, Acceleration 1G, 10-60Hz, 20 Minutes, along Mating Axis 200-260 Hours: Room Temperature	No Damage
27	Repetitive Motion (2)	60±2°C for 1000 Hours 2 Hours Room Temperature	No Damage

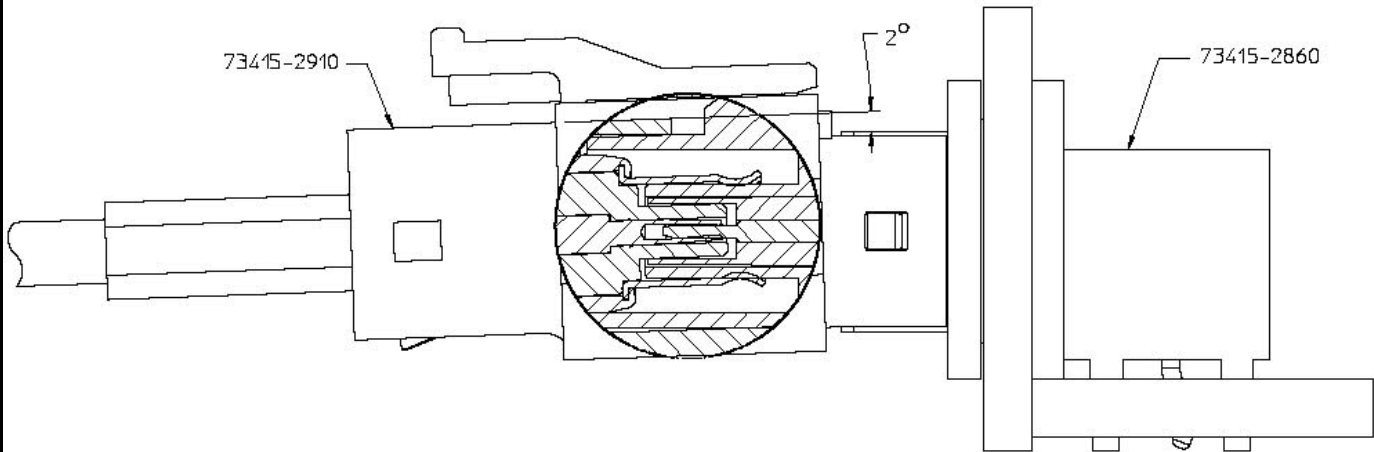

73415-2860/73415-2910 MATED AT 2° ANGLE

Figure 1

REVISION: B2	ECR/ECN INFORMATION: EC No: URF2007-0123 DATE: 2006 / 04 / 10	TITLE: SMB FAKRA 50 OHM (73415-286* & 73415-291*)	SHEET No. 4 of 4
DOCUMENT NUMBER: PS-73598-0360	CREATED / REVISED BY: EVITA LIN	CHECKED BY: James Lin	APPROVED BY: Misen Huang