

NOTES:

1. MATERIALS:

HOUSING, COVER, AND TAIL ALIGNER: HIGH TEMPERATURE THERMOPLASTIC, UL94, V-0 RATED, COLOR: BLACK
 TERMINAL: PHOSPHOR BRONZE ALLOY
 BRACKET: BRASS
 SHELL: STEEL
 INSERT: BRASS

2. FINISHES:

TERMINAL: 0.05-0.25 MICROMETERS GOLD FLASH IN CRITICAL AREA OVER 0.75 MICROMETERS MINIMUM PALLADIUM NICKEL IN CRITICAL AREA, 1.87 MICROMETERS MINIMUM TIN IN SOLDER TAIL AREA, ALL OVER NICKEL.
 BRACKET: 5.0 MICROMETERS MINIMUM BRIGHT TIN.
 SHIELD: 3.81 MICROMETERS MINIMUM BRIGHT TIN OVER 1.27 MICROMETERS MINIMUM NICKEL OVER COPPER FLASH (OPTIONAL).
 INSERT: 2.54 MICROMETERS MINIMUM NICKEL.

3. PRODUCT SPECIFICATION: PS-71425-9999.

4. PACKAGING SPECIFICATION: TRAY PACK PER PK-74337-001.

5. APPLICABLE STANDARDS: EIA-700A0AF AND SFF-8441.

△ DATE CODE: YR/WK PER EIA-476-A.

7. THE PRIMARY SHIPPING CARTON WILL BE LABELED "COMPLIANT TO ROHS DIRECTIVE 2002/95/EC AND ELV ANNEX II OF DERECTIVE 200/53/EC". CARTONS WITHOUT THIS LABEL MAY CONTAIN PRODUCT WITH LEAD.

8. TORQUE TO INSTALL SCREWLOCKS INTO THREADED INSERTS: 0.34 Nm MAXIMUM.

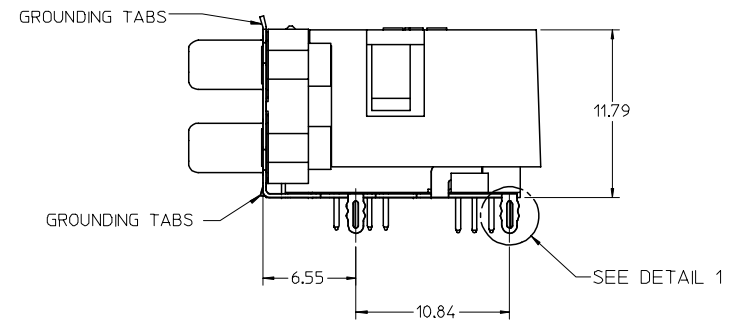
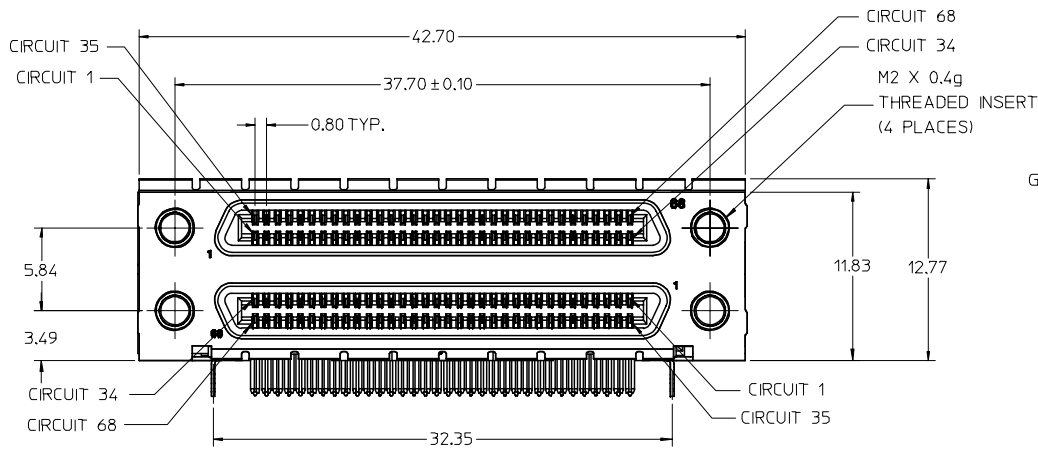
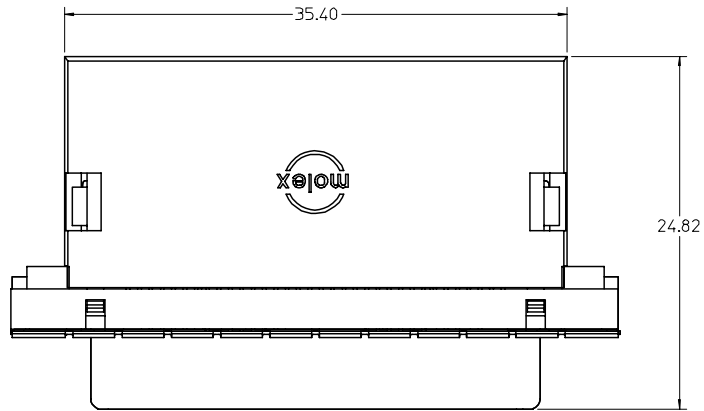

PRESS FIT FORKLOCK SHOWN (VERSION 4)

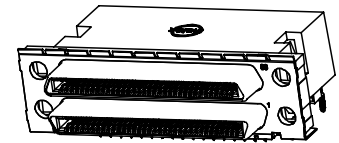

WITH COVER OPTION

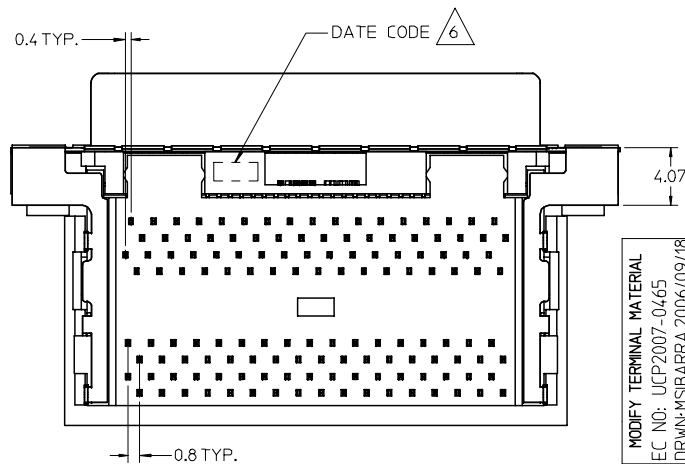

MODIFY TERMINAL MATERIAL EC NO: UCP2007-0465 DRWN: MSIBARRA 2006/09/18 CHKD: DMORGAN 2006/09/26 APPR: SMILLER 2006/09/27	QUALITY SYMBOLS ▽ = 0 ▽ = 0	GENERAL TOLERANCES (UNLESS SPECIFIED)		SCALE 3:1	DESIGN UNITS METRIC	THIRD ANGLE PROJECTION	REVISE ON CAD ONLY	
		DIMENSION STYLE MM ONLY	TITLE VHDCI STACKED ASSEMBLY		MOLEX INCORPORATED			
		4 PLACES ± --- ± --- 3 PLACES ± --- ± --- 2 PLACES ± 0.13 ± --- 1 PLACE ± 0.25 ± ---	DRAWN BY DATE SSAMPSON 05.08.2001	CHECKED BY DATE MBANAKIS 05.08.2001	APPROVED BY DATE MBANAKIS 05.08.2001	MATERIAL NO. SEE TABLE	DOCUMENT NO. SD-74337-014	SHEET NO. 1 OF 4
		DRAFT WHERE APPLICABLE MUST REMAIN WITHIN DIMENSIONS		THIS DRAWING CONTAINS INFORMATION THAT IS PROPRIETARY TO MOLEX INCORPORATED AND SHOULD NOT BE USED WITHOUT WRITTEN PERMISSION				

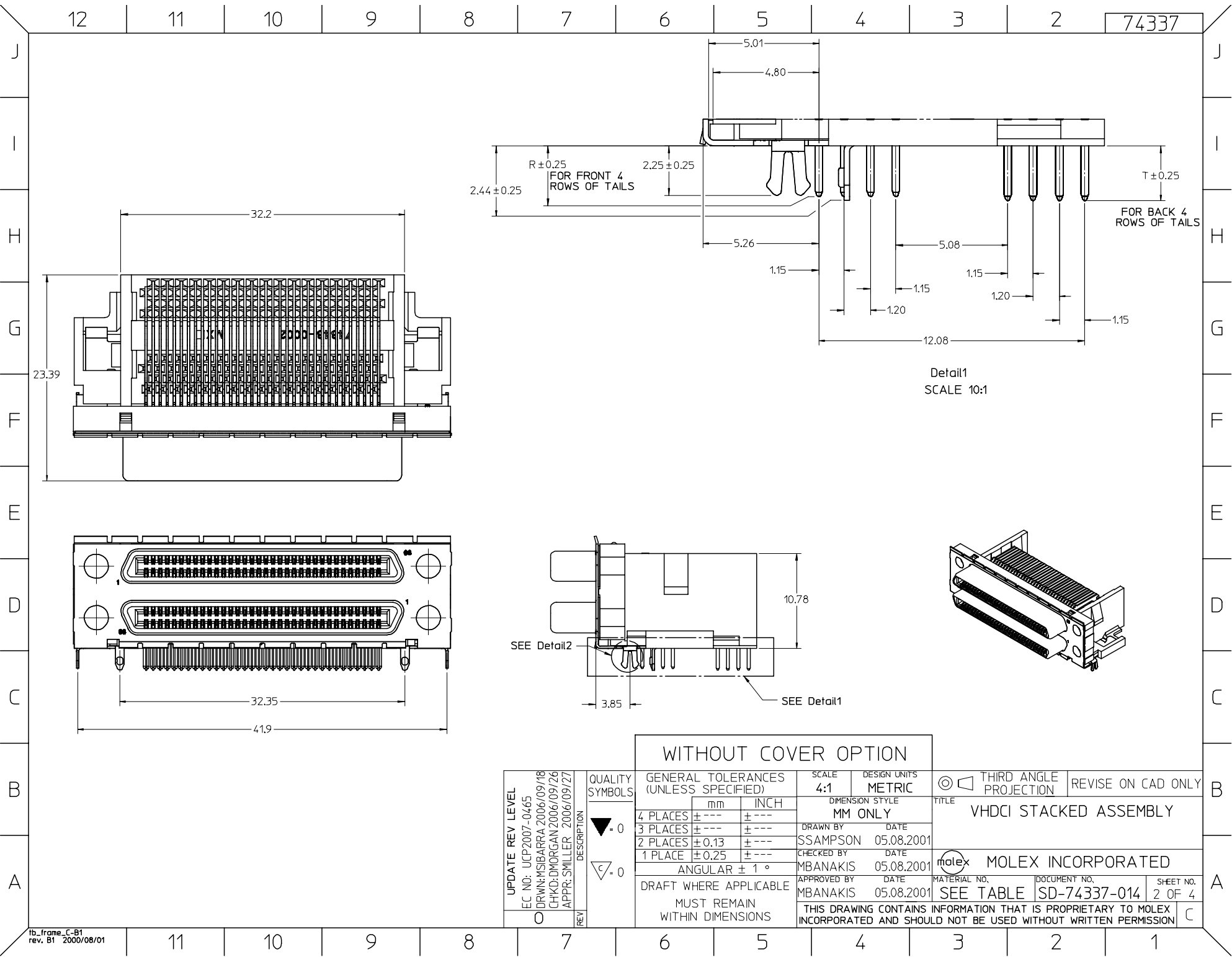

Detail1
SCALE 10:1

UPDATE REV LEVEL	QUALITY SYMBOLS
EC NO: UCP2007-0465	▽ = 0
DRWN: MSIBARRA 2006/09/18	∇ = 0
CHKD: DMORGAN 2006/09/26	
APPR: SMILLER 2006/09/27	
REV	DESCRIPTION
0	

WITHOUT COVER OPTION		
GENERAL TOLERANCES (UNLESS SPECIFIED)		SCALE 4:1
		DESIGN UNITS METRIC
		DIMENSION STYLE MM ONLY
4 PLACES	± ---	
3 PLACES	± ---	
2 PLACES	± 0.13	
1 PLACE	± 0.25	
ANGULAR ± 1 °		
DRAFT WHERE APPLICABLE		
MUST REMAIN WITHIN DIMENSIONS		

THIRD ANGLE PROJECTION	REVISE ON CAD ONLY
TITLE VHDCI STACKED ASSEMBLY	
MOLEX INCORPORATED	
MATERIAL NO. SEE TABLE	DOCUMENT NO. SD-74337-014
SHEET NO. 2 OF 4	

VERSION 1 PART NUMBERS

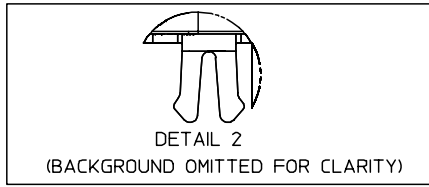

BOARD RETENTION: SNAP FIT

PCB THICKNESS	COVER	R DIM.	T DIM.	INCLUDES LOOSE PACKED SCREWLOCKS 71433-0002 SEE DRAWING SD-71433-005	GROUNDING TABS	PART NUMBER
1.60±0.16	YES	2.30	2.48	NO	YES	74337-0011
1.60±0.16	YES	2.08		NO	YES	74337-0012
1.60±0.16	NO	2.30	2.48	NO	YES	74337-0015
1.60±0.16	NO	2.08		NO	YES	74337-0016
1.60±0.16	YES	2.30	2.48	YES	YES	74337-0037
1.60±0.16	YES	2.08		YES	YES	74337-0038
1.60±0.16	NO	2.30	2.48	YES	YES	74337-0039
1.60±0.16	NO	2.08		YES	YES	74337-0040
2.36±0.16	YES	3.44	3.62	NO	YES	74337-0070
2.36±0.16	NO	3.44	3.62	NO	YES	74337-0071
2.36±0.16	YES	3.44	3.62	YES	YES	74337-0072
2.36±0.16	NO	3.44	3.62	YES	YES	74337-0073
1.60±0.16	YES	2.08		INSTALLED ON PART	YES	74337-1038

VERSION 4 PART NUMBERS



BOARD RETENTION: PRESS FIT

PCB THICKNESS	COVER	R DIM.	T DIM.	INCLUDES LOOSE PACKED SCREWLOCKS 71433-0002 SEE DRAWING SD-71433-005	GROUNDING TABS	PART NUMBER
1.60±0.16	YES	2.30	2.48	NO	YES	74337-0050
1.60±0.16	YES	2.08		NO	NO	74337-0051
1.60±0.16	NO	2.30	2.48	NO	YES	74337-0060
1.60±0.16	NO	2.08		NO	YES	74337-0061
1.60±0.16	YES	2.08		NO	YES	74337-0066
1.60±0.16	YES	2.30	2.48	YES	YES	74337-0053
1.60±0.16	YES	2.08		YES	YES	74337-0054
1.60±0.16	NO	2.30	2.48	YES	YES	74337-0063
1.60±0.16	NO	2.08		YES	YES	74337-0064
2.36±0.16	YES	3.44	3.62	NO	YES	74337-0052
2.36±0.16	NO	3.44	3.62	NO	YES	74337-0062
2.36±0.16	YES	3.44	3.62	YES	YES	74337-0055
2.36±0.16	NO	3.44	3.62	YES	YES	74337-0065
1.60±0.16	YES	2.08		INSTALLED ON PART	YES	74337-1054

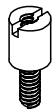

OPTIONAL SCREWLOCK
71433-0002

UPDATE REV LEVEL EC NO: UCP2007-0465 DRN: MSIBARRA 2006/09/18 CHKD: DMORGAN 2006/09/26 APPR: SMILLER 2006/09/27	QUALITY SYMBOLS ▽=0 ◻=0	GENERAL TOLERANCES (UNLESS SPECIFIED)		SCALE 3:1	DESIGN UNITS METRIC	THIRD ANGLE PROJECTION	REVISE ON CAD ONLY	
		mm	INCH	DIMENSION STYLE MM ONLY		TITLE VHDCI STACKED ASSEMBLY		
		4 PLACES ± --- ± ---	3 PLACES ± --- ± ---	DRAWN BY SSAMPSON	DATE 05.08.2001	MATERIAL NO. MOLEX INCORPORATED		
		2 PLACES ± 0.13 ± ---	1 PLACE ± 0.25 ± ---	CHECKED BY MBANAKIS	DATE 05.08.2001	DOCUMENT NO. SD-74337-014	SHEET NO. 3 OF 4	
DRAFT WHERE APPLICABLE MUST REMAIN WITHIN DIMENSIONS		THIS DRAWING CONTAINS INFORMATION THAT IS PROPRIETARY TO MOLEX INCORPORATED AND SHOULD NOT BE USED WITHOUT WRITTEN PERMISSION						

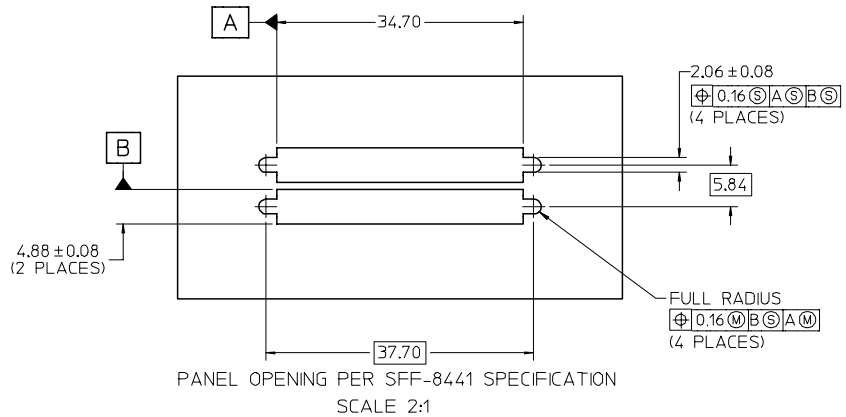
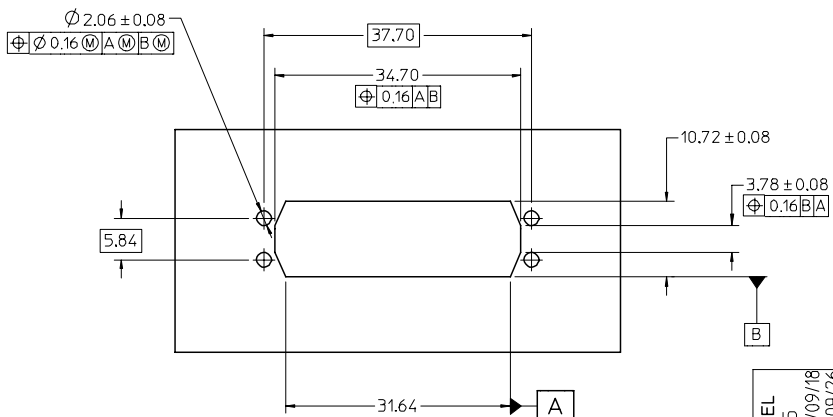
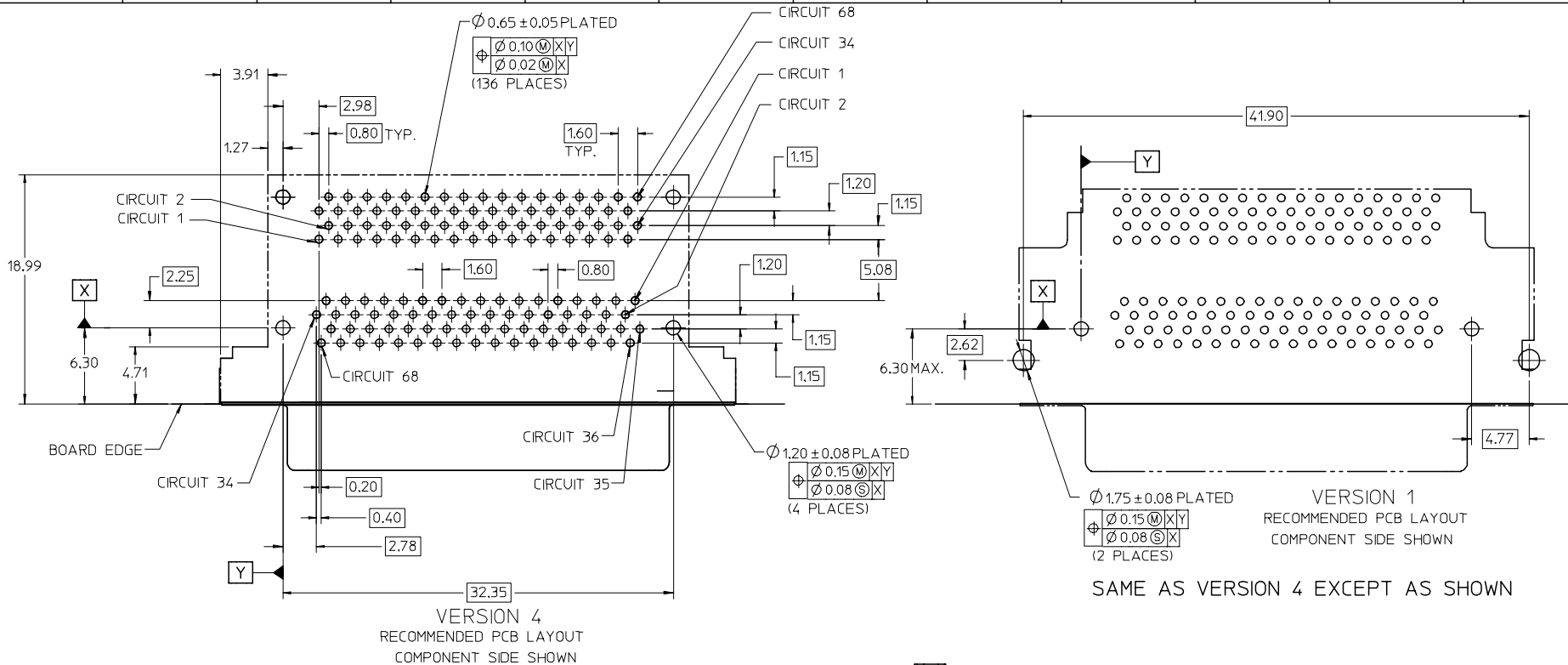

NOTE:
FOR FULL MATE WITH PLUG, PANEL THICKNESS SHOULD NOT EXCEED 1.0mm.
FUNCTIONAL MATING WITH MOLEX PLUG CAN STILL BE MAINTAINED WITH PANELS AS THICK AS 2.5mm (BUT PLUG AND RECEPTACLE WILL NOT BE FULLY MATED).

UPDATE REV LEVEL EC NO: UCP2007-0465 DRWN:MSIBARRA 2006/09/18 CHKD:DMORGAN 2006/09/26 APPR:SMILLER 2006/09/27	QUALITY SYMBOLS	GENERAL TOLERANCES (UNLESS SPECIFIED)	SCALE 3:1	DESIGN UNITS METRIC	THIRD ANGLE PROJECTION	REVISE ON CAD ONLY
	▽ -0 ∇ -0	mm	INCH	DIMENSION STYLE	TITLE	
		4 PLACES ± ---	± ---	MM ONLY	VHDCI STACKED ASSEMBLY	
	O	DESCRIPTION	2 PLACES ± 0.13	DRAWN BY DATE	CHECKED BY DATE	MATERIAL NO. DOCUMENT NO. SHEET NO.
ANGULAR ± 1°		± 0.25	SSAMPSON 05.08.2001	MBANAKIS 05.08.2001	SEE TABLE	SD-74337-014 4 OF 4
	DRAFT WHERE APPLICABLE	MUST REMAIN WITHIN DIMENSIONS	APPROVED BY DATE		THIS DRAWING CONTAINS INFORMATION THAT IS PROPRIETARY TO MOLEX INCORPORATED AND SHOULD NOT BE USED WITHOUT WRITTEN PERMISSION	