

LEAD-FREE PLATING

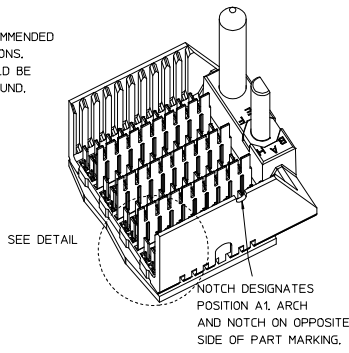
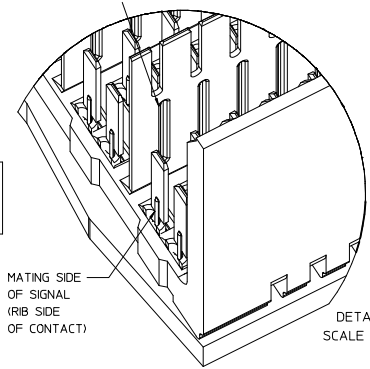

THE PRIMARY CARTON WITH A LABEL STATING "ELV AND RoHS COMPLIANT" IS LEAD-FREE. CARTONS WITHOUT THIS LABEL MAY CONTAIN LEAD.

- NOTES:
1. MATERIAL: HOUSING - LIQUID CRYSTAL POLYMER (LCP) GLASS-FILLED. UL 94V-0. COLOR - GRAY. SIGNAL CONTACT AND GROUND BLADE - HIGH PERFORMANCE COPPER ALLOY.
 2. FINISHES: SELECTIVE GOLD (Au) ON CONTACT AREA, SELECTIVE MATTE TIN (Sn) ON PCB TAILS, NICKEL (Ni) OVERALL.
 3. THIS PART CONFORMS TO MOLEX PRODUCT SPECIFICATION PS-75221-999.
 4. FOR MIXED CONTACT MATING LENGTHS CONSULT MOLEX FOR AVAILABILITY. CONTACT PAIRS MUST BE THE SAME LENGTH.
 5. FOR SPECIFIC PART NUMBER AND MATING INFORMATION PLEASE REFER TO CHART.
 6. PACKAGE PER PK-70873-563.
 7. MARK PART NUMBER AND DATE CODE APPROXIMATELY WHERE SHOWN.
 8. OPTIONAL HOLE LOCATION FOR GROUNDED GUIDE PIN OR ADDITIONAL GUIDE PIN SUPPORT. FOR GROUNDED GUIDE PIN, HOLE TO BE PLATED, DRILL SIZE #258. PAD SIZE #550.
 9. THESE PARTS CONFORM TO MOLEX COSMETIC SPECIFICATION PS-45499-002 CLASS B.
 10. MAPS (MOLEX ADVANCED PLATING SYSTEM).

ASSY PART NO.	K	L	P	TOTAL NO. OF DIFFERENTIAL PAIRS
75235-21**	9	16.65	24.78	40
75235-22**	24	44.40	52.53	100

P/N	---0*	---1*	---2*	---3*	---4*	---5*	---6*	---7*	---8*
75235-()	0	A	B	C	D	E	F	G	H

PIN LENGTH DIM 'M'	GOLD (Au) THICKNESS micrometers
0-3.55 mm	0.25 (MAPS)
1-4.55 mm	
2-5.55 mm	
3-5.55 mm	
4-4.55 mm	0.76
5-5.55 mm	
7-3.55 mm	
8-4.55 mm	1.27
9-5.55 mm	

REV TO LEADFREE
 EC NO: UCP2013-1905
 DRN: MWLF 2012/09/07
 CHK: SWAG 2012/09/07
 APPR: MILLER 2012/12/05

QUALITY SYMBOLS	GENERAL TOLERANCES (UNLESS SPECIFIED)	DIMENSION STYLE	SCALE	DESIGN UNITS	THIRD ANGLE PROJECTION
▽=0	4 PLACES ±--- INCH	MM ONLY	5:1	METRIC	THIRD ANGLE PROJECTION
▽=0	3 PLACES ±--- INCH	DRAWN BY DATE			
▽=0	2 PLACES ±0.25 INCH	CHECKED BY DATE			
	1 PLACE ±0.38 INCH	APPROVED BY DATE			
	0 PLACE ± INCH	CBI XLER 2003/10/22			
	ANGULAR ±---	MATERIAL NO.	DOCUMENT NO.		
	DRAFT WHERE APPLICABLE MUST REMAIN WITHIN DIMENSIONS	SEE TABLE	SD-75235-210		

GBX 4-PAIR LF LEFT END BACKPLANE SALES ASSEMBLY

molex

SHEET NO. 1 OF 1

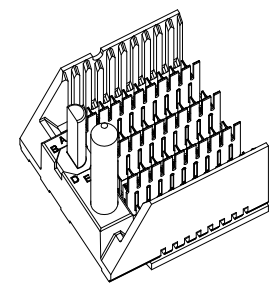
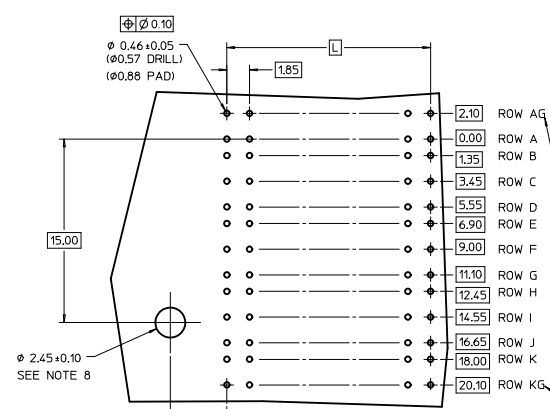
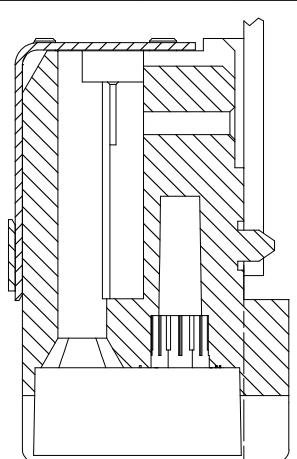
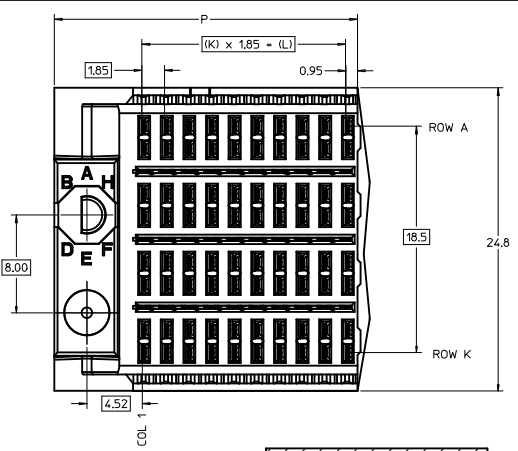

**LEAD-FREE
PLATING ON
SIGNALS, & GROUNDS.**

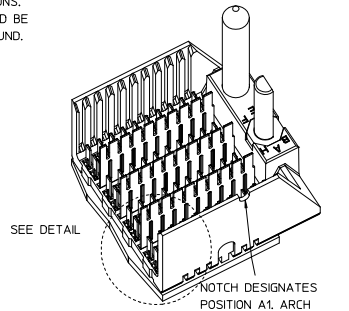
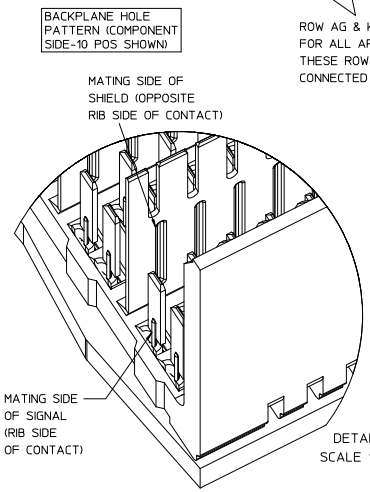
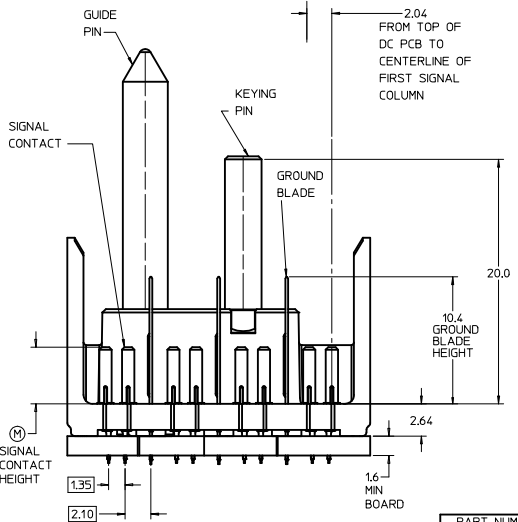
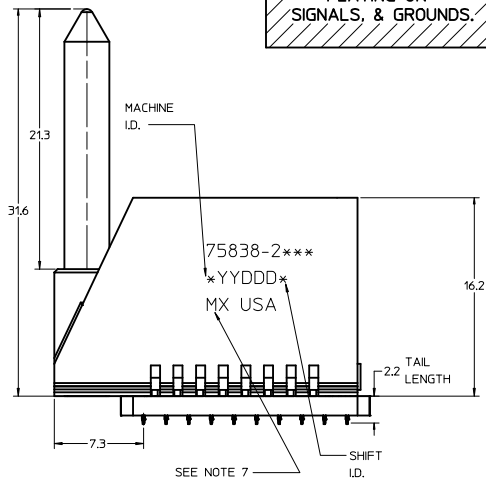

- NOTES:**
- MATERIAL: HOUSING - LIQUID CRYSTAL POLYMER (LCP) GLASS-FILLED. UL 94V-0, COLOR - GRAY. SIGNAL CONTACT AND GROUND BLADE - HIGH PERFORMANCE COPPER ALLOY.
 - FINISHES: SELECTIVE GOLD (Au) 0.25 (MAPS), 0.76, OR 1.27 micrometers THICKNESS ON CONTACT AREA. SELECTIVE MATTE TIN (Sn) ON PCB TAILS. NICKEL (Ni) OVERALL.
 - THIS PART CONFORMS TO MOLEX PRODUCT SPECIFICATION PS-75221-999.
 - FOR MIXED CONTACT MATING LENGTHS CONSULT MOLEX FOR AVAILABILITY. CONTACT PAIRS MUST BE THE SAME LENGTH.
 - FOR SPECIFIC PART NUMBER AND MATING INFORMATION PLEASE REFER TO CHART.
 - PACKAGE PER PK-70873-563.
 - EITHER MARK PART NUMBER AND DATE CODE APPROXIMATELY WHERE SHOWN OR PLACE A LABEL ON THE TUBE.
 - OPTIONAL HOLE LOCATION FOR GROUNDED GUIDE PIN OR ADDITIONAL GUIDE PIN SUPPORT. FOR GROUNDED GUIDE PIN, HOLE TO BE PLATED, DRILL SIZE Ø2.58, PAD SIZE Ø5.50
 - THESE PARTS CONFORM TO MOLEX COSMETIC SPECIFICATION PS-45499-02 CLASS B.

PART NUMBER TABLE				
ASSY PART NO.	K	L	P	TOTAL NO. OF DIFFERENTIAL PAIRS
75838-21**	9	16,65	24,78	40
75838-22**	24	44,40	52,53	100

P/N	--*0*	--*1*	--*2*	--*3*	--*4*	--*5*	--*6*	--*7*	--*8*
75838-()	0	A	B	C	D	E	F	G	H

MODULE ORIENTATION LEFT = 2

KEYING ORIENTATION
 0 = NONE
 1 = A
 2 = B
 ETC...

PIN LENGTH DIM "M"	GOLD (Au) THICKNESS micrometers
0-3.55 mm	0.25
1-4.55 mm	
2-5.55 mm	
3-3.55 mm	
4-4.55 mm	0.76
5-5.55 mm	
7-3.55 mm	
8-4.55 mm	
9-5.55 mm	1.27

ADD MAPS PLATING
 EC NO: UCP2012-3688
 DRAWN BY: CHYOSANALLEY 2012/05/16
 CHECKED BY: APPROX: MILLER 2012/05/23

QUALITY SYMBOLS
 ∇=0
 ∇=0
 ∇=0

GENERAL TOLERANCES (UNLESS SPECIFIED)

	mm	INCH
4 PLACES ±	---	---
3 PLACES ±	---	---
2 PLACES ±	0.25	---
1 PLACE ±	0.38	---
0 PLACE ±	---	---

ANGULAR ± ---°
 DRAFT WHERE APPLICABLE MUST REMAIN WITHIN DIMENSIONS

DIMENSION STYLE
 MM ONLY

SCALE
 5:1

DESIGN UNITS
 METRIC

THIRD ANGLE PROJECTION

TITLE
 GBX 4-PAIR LEFT END BACKPLANE ASSEMBLY LEAD-FREE SALES DRAWING

molex

MATERIAL NO.
 SEE TABLE

DOCUMENT NO.
 SD-75838-210

SHEET NO.
 1 OF 1

INCORPORATED AND SHOULD NOT BE USED WITHOUT WRITTEN PERMISSION