

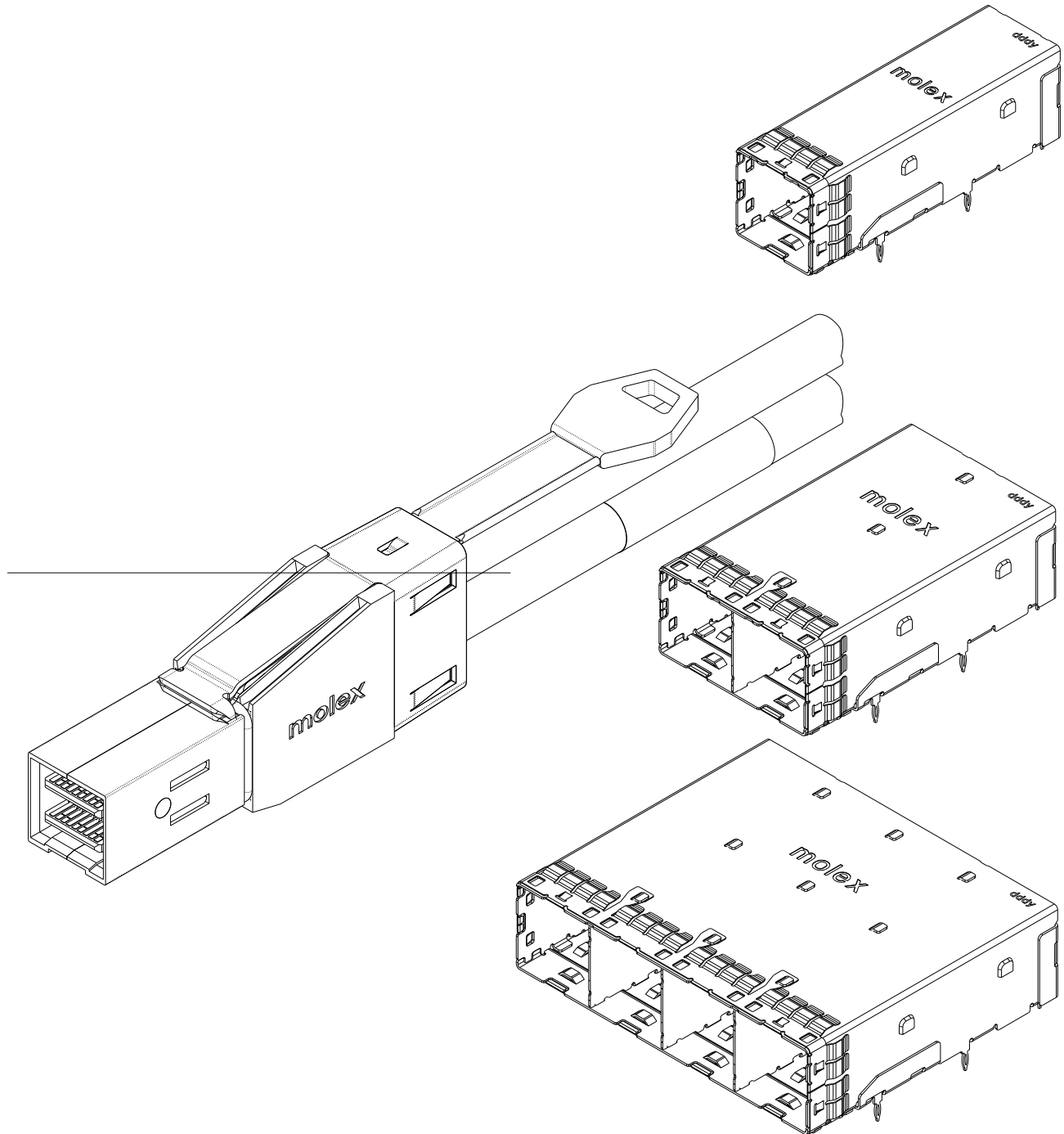

PRODUCT SPECIFICATION

iPass+ HD EXTERNAL R/A CONNECTOR SYSTEM



REVISION: B	ECR/ECN INFORMATION: EC No: 613300 DATE: 2019 / 03/ 06	TITLE: PRODUCT SPECIFICATION iPass+ HD Series R/A External I/O Connector & Cable	SHEET No. 1 of 19
DOCUMENT NUMBER: PS-76866-001	CREATED / REVISED BY: KBINGHAM	CHECKED BY: TMcCLELLAND	APPROVED BY: TMcCLELLAND



PRODUCT SPECIFICATION

TABLE OF CONTENTS

1.0	SCOPE.....	4
2.0	PRODUCT DESCRIPTION.....	4
2.1	PRODUCT NAME AND SERIES NUMBER(S).....	4
2.2	DIMENSION, MATERIALS, PLATING AND MARKINGS.....	4
2.3	SAFETY AGENCY APPROVALS.....	4
2.4	PIN ASSIGNMENTS	4
2.5	ADDITIONAL GENERAL SPECIFICATIONS	4
3.0	APPLICABLE DOCUMENTS AND SPECIFICATIONS.....	5
3.1	MOLEX DOCUMENTS.....	5
3.2	INDUSTRY DOCUMENTS.....	5
4.0	QUALIFICATION.....	5
5.0	RATINGS.....	5
5.1	VOLTAGE.....	5
5.2	CURRENT.....	5
5.3	TEMPERATURE	5
5.4	DURABILITY	5
5.5	FIELD LIFE	5
6.0	PERFORMANCE (MECHANICAL & ENVIRONMENTAL).....	6
6.1	TEST GROUP 1 – TEMPERATURE LIFE.....	6
6.2	TEST GROUP 2 – CYCLIC TEMPERATURE & HUMIDITY	7
6.3	TEST GROUP 3 – MECHANICAL VIBRATION.....	8
6.4	TEST GROUP 4 – MIXED FLOWING GAS	9
	TEST GROUP 4 (CONTINUED)	10
6.5	TEST GROUP 7 – DIELECTRIC WITHSTANDING VOLTAGE	11
6.6	MECHANICAL TEST GROUP 1	12
6.7	MECHANICAL TEST GROUP 2	12
6.8	MECHANICAL TEST GROUP 3	13
6.9	MECHANICAL TEST GROUP 4.....	13
6.10	MECHANICAL TEST GROUP 5	13
6.11	MECHANICAL TEST GROUP 6.....	14
6.12	MECHANICAL TEST GROUP 7	14
6.13	MECHANICAL TEST GROUP 8	14
7.0	PERFORMANCE (HIGH SPEED CHARACTERIZATION).....	15
7.1	SIGNAL INTEGRITY REQUIREMENTS (CONNECTOR ONLY).....	15
7.2	SIGNAL INTEGRITY REQUIREMENTS (CONNECTOR & CABLE SYSTEM, SAS/SATA)	16
8.0	PACKAGING.....	17
8.1	CONNECTOR AND CAGE.....	17

REVISION: B	EGR/ECN INFORMATION: EC No: 613300 DATE: 2019 / 03 / 06	TITLE: PRODUCT SPECIFICATION iPass+ HD Series R/A External I/O Connector & Cable	SHEET No. 2 of 19
DOCUMENT NUMBER: PS-76866-001	CREATED / REVISED BY: KBINGHAM	CHECKED BY: TMcCLELLAND	APPROVED BY: TMcCLELLAND



PRODUCT SPECIFICATION

8.2	PLUG AND CABLE ASSEMBLY	17
9.0	GAGES AND FIXTURES	18
10.0	OTHER INFORMATION	19
THIS PAGE INTENTIONALLY LEFT BLANK		19

REVISION: B	ECR/ECN INFORMATION: EC No: 613300 DATE: 2019 / 03/ 06	TITLE: PRODUCT SPECIFICATION iPass+ HD Series R/A External I/O Connector & Cable	SHEET No. 3 of 19
DOCUMENT NUMBER: PS-76866-001	CREATED / REVISED BY: KBINGHAM	CHECKED BY: TMcCLELLAND	APPROVED BY: TMcCLELLAND



PRODUCT SPECIFICATION

1.0 SCOPE

This Product Specification covers this 0.75 mm centerline (pitch) printed circuit board (PCB) connector series and cable assemblies.

2.0 PRODUCT DESCRIPTION

2.1 PRODUCT NAME AND SERIES NUMBER(S)

Product Name:	iPass+ HD External R/A Connector
Cage/Connector Series:	76866
Plug & Cable Series:	111068, 111073, 111075, 111077

2.2 DIMENSION, MATERIALS, PLATING AND MARKINGS

See the appropriate sales drawing for information on dimensions, materials, plating, marking, and footprint patterns.

2.3 SAFETY AGENCY APPROVALS

UL file:	E107635
CSA file:	19980

2.4 PIN ASSIGNMENTS

Pin assignment may vary depending on the cable assembly configuration. Different configurations will have different part numbers within the series. Reference the appropriate cable sales drawing of the specific part number for the correct pin assignment.

2.5 ADDITIONAL GENERAL SPECIFICATIONS

Plug PCB:

- Material is FR4
- Overall thickness of 1mm over pads
- Contacts are 0.76µm minimum hard gold plated over 3.81µm minimum thick nickel plating

Plug:

- Backshells – Zinc Diecast
- Pull – Nylon
- Latch – Stainless Steel

Bulk Cable:

- See specific sales drawing

REVISION: B	ECR/ECN INFORMATION: EC No: 613300 DATE: 2019 / 03 / 06	TITLE: PRODUCT SPECIFICATION iPass+ HD Series R/A External I/O Connector & Cable	SHEET No. 4 of 19
DOCUMENT NUMBER: PS-76866-001	CREATED / REVISED BY: KBINGHAM	CHECKED BY: TMcCLELLAND	APPROVED BY: TMcCLELLAND



PRODUCT SPECIFICATION

3.0 APPLICABLE DOCUMENTS AND SPECIFICATIONS

3.1 MOLEX DOCUMENTS

TS-76866-001 Test Summary – iPass+ HD Series
 AS-76866-001 Application Specification
 AS-76866-002 Application Specification – Routing Guide
 PK-76866-001 Packaging Specification
 PS-45499-002 Cosmetic Specification (Receptacle)

3.2 INDUSTRY DOCUMENTS

EIA 364 Series Electrical Connector Test Procedures Including Environmental Classifications with Test Procedures
 EIA 364-1000 Environmental Test Methodology for Assessing the Performance of Connectors and Sockets Used in Business Office Applications

4.0 QUALIFICATION

Laboratory condition and sample selection are in accordance with EIA 364

5.0 RATINGS

5.1 VOLTAGE

30 Volts AC (RMS)/DC Max.

5.2 CURRENT

0.75 Amps Max.

5.3 TEMPERATURE

Maximum Operating: +80°C
 Non-operating: -55°C to +80°C

5.4 DURABILITY

PL1 – Performance Level 1 – 0.76 μm Au – 250 cycles

5.5 FIELD LIFE

+85°C, 5 year, 14 day MFG

REVISION: B	ECR/ECN INFORMATION: EC No: 613300 DATE: 2019 / 03 / 06	TITLE: PRODUCT SPECIFICATION iPass+ HD Series R/A External I/O Connector & Cable	SHEET No. 5 of 19
DOCUMENT NUMBER: PS-76866-001	CREATED / REVISED BY: KBINGHAM	CHECKED BY: TMcCLELLAND	APPROVED BY: TMcCLELLAND



PRODUCT SPECIFICATION

6.0 PERFORMANCE (MECHANICAL & ENVIRONMENTAL)

6.1 TEST GROUP 1 – TEMPERATURE LIFE

ITEM	TEST	TEST PROCEDURE	CONDITION	REQUIREMENT
1	Low Level Contact Resistance	EIA-364-23; apply a maximum voltage of 20 mV and a current of 100 mA.	Mated	PL1 – baseline
2	Durability (precondition)	EIA-364-09; perform plug & unplug cycles: PL1 (50)		No evidence of physical damage
3	Temperature Life	EIA-364-17, method A, Test Condition 3 at 105°±2°C PL1 – 240 hours	Mated	Conditioning Exposure
4	Low Level Contact Resistance	EIA-364-23; apply a maximum voltage of 20 mV and a current of 100 mA.	Mated	PL1 - <10 mΩ Δ max from initial
5	Reseating	Manually unplug & plug the connector, 3 cycles		No evidence of physical damage
6	Low Level Contact Resistance	EIA-364-23; apply a maximum voltage of 20 mV and a current of 100 mA.	Mated	PL1 - <10 mΩ Δ max from initial

REVISION: B	ECR/ECN INFORMATION: EC No: 613300 DATE: 2019 / 03 / 06	TITLE: PRODUCT SPECIFICATION iPass+ HD Series R/A External I/O Connector & Cable	SHEET No. 6 of 19
DOCUMENT NUMBER: PS-76866-001	CREATED / REVISED BY: KBINGHAM	CHECKED BY: TMcCLELLAND	APPROVED BY: TMcCLELLAND



PRODUCT SPECIFICATION

6.2 TEST GROUP 2 – CYCLIC TEMPERATURE & HUMIDITY

ITEM	TEST	TEST PROCEDURE	CONDITION	REQUIREMENT
1	Low Level Contact Resistance	EIA-364-23; apply a maximum voltage of 20 mV and a current of 100 mA.	Mated	PL1 - baseline
2	Durability (precondition)	EIA-364-09; perform plug & unplug cycles: PL1 (50)		No evidence of physical damage
3	Thermal Shock	EIA-364-32, method A test condition I (10 cycles)	Mated	Conditioning Exposure
4	Low Level Contact Resistance	EIA-364-23; apply a maximum voltage of 20 mV and a current of 100 mA.	Mated	PL1 - <10 mΩ Δ max from initial
5	Cyclic Temperature & Humidity	EIA-364-31 Cycle connectors between 25° ± 3°C at 80% RH and 65 °± 3 °C at 50% RH: PL1 (24), PL2(N/A) cycles. Ramp times should be 0.5 hour and dwell should be 1.0 hour.	Mated	Conditioning Exposure
6	Low Level Contact Resistance	EIA-364-23; apply a maximum voltage of 20 mV and a current of 100 mA.	Mated	PL1 - <10 mΩ Δ max from initial
7	Reseating	Manually unplug & plug the connector, 3 cycles		No evidence of physical damage
8	Low Level Contact Resistance	EIA-364-23; apply a maximum voltage of 20 mV and a current of 100 mA.	Mated	PL1 - <10 mΩ Δ max from initial

REVISION: B	ECR/ECN INFORMATION: EC No: 613300 DATE: 2019 / 03 / 06	TITLE: PRODUCT SPECIFICATION iPass+ HD Series R/A External I/O Connector & Cable	SHEET No. 7 of 19
DOCUMENT NUMBER: PS-76866-001	CREATED / REVISED BY: KBINGHAM	CHECKED BY: TMcCLELLAND	APPROVED BY: TMcCLELLAND



PRODUCT SPECIFICATION

6.3 TEST GROUP 3 – MECHANICAL VIBRATION

ITEM	TEST	TEST PROCEDURE	CONDITION	REQUIREMENT
1	Low Level Contact Resistance	EIA-364-23; apply a maximum voltage of 20 mV and a current of 100 mA.	Mated	PL1 - baseline
2	Durability (precondition)	EIA-364-09; perform plug & unplug cycles: PL1 (50)		No evidence of physical damage
3	Temperature Life (precondition)	EIA-364-17, method A, Test Condition 3 at 105±2°C PL1 – 336 hours	Mated	Conditioning Exposure
4	Low Level Contact Resistance	EIA-364-23; apply a maximum voltage of 20 mV and a current of 100 mA.	Mated	PL1 - <10 mΩ Δ max from initial
5	Mechanical Vibration	EIA-364-28 test condition VII test condition letter D 15 minutes in each of 3 mutually perpendicular directions. Both mating halves rigidly fixed to not contribute to relative motion of one contact against another.	Mated	Discontinuity < 1 μsec No evidence of physical damage
6	Low Level Contact Resistance	EIA-364-23; apply a maximum voltage of 20 mV and a current of 100 mA.	Mated	PL1 - <10 mΩ Δ max from initial

REVISION: B	ECR/ECN INFORMATION: EC No: 613300 DATE: 2019 / 03 / 06	TITLE: PRODUCT SPECIFICATION iPass+ HD Series R/A External I/O Connector & Cable	SHEET No. 8 of 19
DOCUMENT NUMBER: PS-76866-001	CREATED / REVISED BY: KBINGHAM	CHECKED BY: TMcCLELLAND	APPROVED BY: TMcCLELLAND



PRODUCT SPECIFICATION

6.4 TEST GROUP 4 – MIXED FLOWING GAS

ITEM	TEST	TEST PROCEDURE	CONDITION	REQUIREMENT
1	Low Level Contact Resistance	EIA-364-23; apply a maximum voltage of 20 mV and a current of 100 mA.	Mated	PL1 - baseline
2	Durability (precondition)	EIA-364-09; perform plug & unplug cycles: PL1 (50)		No evidence of physical damage
3	Temperature Life (precondition)	EIA-364-17, method A, Test Condition 3 at 105 \pm 2 $^{\circ}$ C PL1 – 336 hours	Mated	Conditioning Exposure
4	Low Level Contact Resistance	EIA-364-23; apply a maximum voltage of 20 mV and a current of 100 mA.	Mated	PL1 - <10 m Ω Δ max from initial
5	Mixed Flowing Gas	EIA-364-65 class IIA, Option 1A & 1B test condition VII PL1 – 14 days (336 hours) See Note	Unmated	Conditioning Exposure
6	Low Level Contact Resistance	EIA-364-23; apply a maximum voltage of 20 mV and a current of 100 mA.	Mated	PL1 - <10 m Ω Δ max from initial

Note:

- For PL1, expose 1/2 of the specimens unmated for 224 hours of the test duration. Mate the specimen to the same one used during preconditioning temperature life. Expose for the duration of the test (112 hours).
- For PL2, expose 1/2 of the specimens unmated for 5 days, mate & un-mate all specimens 1 time, measure LLCR on all specimens. Expose same 1/2 of specimens unmated for 5 days, mate & un-mate all specimens 1 time, measure LLCR on all specimens. Expose all specimens mated for 5 days, mate & un-mate all specimens 1 time, measure LLCR on all specimens. Expose all specimens mated for 5 days, mate & un-mate all specimens 1 time.
- Characterize porosity & plating thickness before test sequence.

REVISION: B	ECR/ECN INFORMATION: EC No: 613300 DATE: 2019 / 03 / 06	TITLE: PRODUCT SPECIFICATION iPass+ HD Series R/A External I/O Connector & Cable	SHEET No. 9 of 19
DOCUMENT NUMBER: PS-76866-001	CREATED / REVISED BY: KBINGHAM	CHECKED BY: TMcCLELLAND	APPROVED BY: TMcCLELLAND



PRODUCT SPECIFICATION

TEST GROUP 4 (CONTINUED)

ITEM	TEST	TEST PROCEDURE	CONDITION	REQUIREMENT
7	Mixed Flowing Gas	EIA-364-65 class IIA, Option 1A & 1B test condition VII PL1 – 112 hours	Mated	None
8	Low Level Contact Resistance	EIA-364-23; apply a maximum voltage of 20 mV and a current of 100 mA.	Mated	PL1 - <10 mΩ Δ max from initial
9	Thermal Disturbance	Cycle connectors 10 times between 15° ± 3°C at 80% RH and 85 °± 3 °C at 50% RH. Ramps should be a minimum of 2°C per minute and dwell times should ensure that the contacts reach the temperature extremes for a minimum of 5 minutes.	Mated	Conditioning Exposure
10	Low Level Contact Resistance	EIA-364-23; apply a maximum voltage of 20 mV and a current of 100 mA.	Mated	PL1 - <10 mΩ Δ max from initial
11	Reseating	Manually unplug & plug the connector, 3 cycles		No evidence of physical damage
12	Low Level Contact Resistance	EIA-364-23; apply a maximum voltage of 20 mV and a current of 100 mA.	Mated	PL1 - <10 mΩ Δ max from initial

REVISION: B	ECR/ECN INFORMATION: EC No: 613300 DATE: 2019 / 03 / 06	TITLE: PRODUCT SPECIFICATION iPass+ HD Series R/A External I/O Connector & Cable	SHEET No. 10 of 19
DOCUMENT NUMBER: PS-76866-001	CREATED / REVISED BY: KBINGHAM	CHECKED BY: TMcCLELLAND	APPROVED BY: TMcCLELLAND



PRODUCT SPECIFICATION

6.5 TEST GROUP 7 – DIELECTRIC WITHSTANDING VOLTAGE

ITEM	TEST	TEST PROCEDURE	CONDITION	REQUIREMENT
1	Dielectric Withstanding Voltage	EIA-364-20; apply a voltage of 300 VDC for 1 minute between adjacent terminals and between adjacent terminals and ground.	Mated	No disruptive discharge No leakage current in excess of 5mA
2	Low Level Contact Resistance	EIA-364-23; apply a maximum voltage of 20 mV and a current of 100 mA.	Mated	PL1 - baseline
3	Durability	EIA-364-09; perform plug & unplug cycles: PL1 (250)		No evidence of physical damage
4	Low Level Contact Resistance	EIA-364-23; apply a maximum voltage of 20 mV and a current of 100 mA.	Mated	PL1 - <10 mΩ Δ max from initial
5	Dielectric Withstanding Voltage	EIA-364-20; apply a voltage of 300 VDC for 1 minute between adjacent terminals and between adjacent terminals and ground.	Mated	No disruptive discharge No leakage current in excess of 5mA

Note:

1. Separate sets of test specimens will be used to access dielectric withstanding voltage and the change in low level contact resistance.
2. Dielectric withstanding voltage testing will use different contacts than those used for low level contact resistance testing.

REVISION: B	ECR/ECN INFORMATION: EC No: 613300 DATE: 2019 / 03/ 06	TITLE: PRODUCT SPECIFICATION iPass+ HD Series R/A External I/O Connector & Cable	SHEET No. 11 of 19
DOCUMENT NUMBER: PS-76866-001	CREATED / REVISED BY: KBINGHAM	CHECKED BY: TMcCLELLAND	APPROVED BY: TMcCLELLAND



PRODUCT SPECIFICATION

6.6 MECHANICAL TEST GROUP 1

ITEM	TEST	TEST PROCEDURE	CONDITION	REQUIREMENT
1	Temperature Rise (via current cycling)	Measure the temperature rise at the rated current after 96 hours. (45 minutes ON and 15 minutes OFF). Fixture as required.	Mated	Temperature Rise: +30°C maximum

6.7 MECHANICAL TEST GROUP 2

ITEM	TEST	TEST PROCEDURE	CONDITION	REQUIREMENT
1	Connector Mate Forces (Module only)	Mate connector at a rate of 25 mm per min.	Mate	60 N MAX insertion force
2	Connector Un-mate Forces (Module only)	Un-mate connector at a rate of 25 mm per min.	Un-mate	30 N MAX withdrawal force
3	Plug Mate Forces	Mate connector at a rate of 25 mm per min.	Mate	4X – 70 N MAX 8X – 140 N MAX
4	De-Latch Plug (Axial Load)	Mate connector and place axial load on latch pull to de-latch plug	Un-mate	4X – 40 N MAX 8X – 70 N MAX
5	Latch Pull (Axial Load)	Place axial load on plug pull	Mate	4X – 35 N MIN 8X – 55 N MIN No Visible Damage

REVISION: B	ECR/ECN INFORMATION: EC No: 613300 DATE: 2019 / 03 / 06	TITLE: PRODUCT SPECIFICATION iPass+ HD Series R/A External I/O Connector & Cable	SHEET No. 12 of 19
DOCUMENT NUMBER: PS-76866-001	CREATED / REVISED BY: KBINGHAM	CHECKED BY: TMcCLELLAND	APPROVED BY: TMcCLELLAND



PRODUCT SPECIFICATION

6.8 MECHANICAL TEST GROUP 3

ITEM	TEST	TEST PROCEDURE	CONDITION	REQUIREMENT
1	Normal Force	Apply a perpendicular force.		0.49 N, (50 grams) MINIMUM normal force

6.9 MECHANICAL TEST GROUP 4

ITEM	TEST	TEST PROCEDURE	CONDITION	REQUIREMENT
1	Latitudinal Load	Mate connector and load plug with latitudinal load until open circuit. See section 9.	Mated	75 N MIN
2	Longitudinal Load	Mate connector and load plug with longitudinal load until open circuit. See section 9.	Mated	75 N MIN
3	Plug Pullout Force (Axial Load)	Mate plug to connector and apply an axial pullout force on the wire at a rate of 25 mm per min.	Mated	100 N MIN Force to overcome Latch
4	Plug Pullout Force (Right Angle Load)	Mate plug to connector and apply a right angle pullout force on the wire at a rate of 25 mm per min.	Mated	75 N MIN

6.10 MECHANICAL TEST GROUP 5

ITEM	TEST	TEST PROCEDURE	CONDITION	REQUIREMENT
1	Continuity		Un-Mated	No Discontinuity
2	Cable Jacket Retention Force (Axial Load)	Apply an axial load of 100 N to cable for 20 seconds	Un-Mated	1 mm Max movement of Cable Jacket
3	Continuity		Un-Mated	No Discontinuity

REVISION: B	ECR/ECN INFORMATION: EC No: 613300 DATE: 2019 / 03 / 06	TITLE: PRODUCT SPECIFICATION iPass+ HD Series R/A External I/O Connector & Cable	SHEET No. 13 of 19
DOCUMENT NUMBER: PS-76866-001	CREATED / REVISED BY: KBINGHAM	CHECKED BY: TMcCLELLAND	APPROVED BY: TMcCLELLAND



PRODUCT SPECIFICATION

6.11 MECHANICAL TEST GROUP 6

ITEM	TEST	TEST PROCEDURE	CONDITION	REQUIREMENT
1	Continuity		Mated	No Discontinuity
2	Wire Flex	Flex cable 180° for 25 cycles, Flexing rate of 14 cycles/min Bending mandrel located 25 mm from cable exit Load on cable – see below 24 AWG – 500 g 24 AWG – 25 mm R mandrel 28 AWG – 300 g 28 AWG – 12.5 mm R mandrel	Mated	Conditioning Exposure
3	Continuity		Mated	No Discontinuity

6.12 MECHANICAL TEST GROUP 7

ITEM	TEST	TEST PROCEDURE	CONDITION	REQUIREMENT
1	Compliant Pin Insertion into PCB	Apply an axial insertion force on the terminal at a rate of 25±6 mm/min.	OSP HASL ENIG	17.7 N (4.0 lbf) max insertion force per pin (Nominal PTH .37ø)
2	Compliant Pin Retention to PCB	Apply an axial extraction force on the terminal at a rate of 25±6 mm/min.	OSP HASL ENIG	2.0 N (0.45 lbf) min retention force per pin (Nominal PTH .37ø)

6.13 MECHANICAL TEST GROUP 8

ITEM	TEST	TEST PROCEDURE	CONDITION	REQUIREMENT
1	Screw Torque (strip out)		Un-Mated	225 N-mm (2.0 in-lbf) min torque

REVISION: B	EGR/ECN INFORMATION: EC No: 613300 DATE: 2019 / 03 / 06	TITLE: PRODUCT SPECIFICATION iPass+ HD Series R/A External I/O Connector & Cable	SHEET No. 14 of 19
DOCUMENT NUMBER: PS-76866-001	CREATED / REVISED BY: KBINGHAM	CHECKED BY: TMcCLELLAND	APPROVED BY: TMcCLELLAND



PRODUCT SPECIFICATION

7.0 PERFORMANCE (HIGH SPEED CHARACTERIZATION)

7.1 SIGNAL INTEGRITY REQUIREMENTS (CONNECTOR ONLY)

ITEM	DESCRIPTION	TEST CONDITION	REQUIREMENT
1	Return Loss	Frequency range 50MHz to 7.5GHz Frequency range 7.5GHz to 15GHz • 2.5dB at 15GHz	≤ -10 dB Equation 1
2	Differential Impedance	Rise-time of 25ps (20-80%)	100 ± 10 ohms
3	Insertion Loss	Frequency range 50 MHz to 12.5 GHz	Equation 2
4	Isolation	Power-sum crosstalk, all Transmit aggressors, and balance of Receive aggressors, Rx0 as victim	-40 dB largest contributor -36 db total power sum Up to 6000 MHz
5	Differential Skew (Within Pair)	Mate plug to receptacle	<1 psec

Note:

PCB Interface Option 1 – Compliant Pin, single port
 PCB Interface Option 2 – Compliant Pin, dual port or stacked ports
 Equation 1: $\leq -10 - 25\log_{10}(f / 7.5\text{GHz})$ dB
 Equation 2: $\leq -20\log_{10}(a1 * \sqrt{f} + a2 * f + a3 * f^2)$ dB
 Where a1=1.0E-0.5, a2=1.0E-10, a3=1.0E-20

REVISION: B	ECR/ECN INFORMATION: EC No: 613300 DATE: 2019 / 03 / 06	TITLE: PRODUCT SPECIFICATION iPass+ HD Series R/A External I/O Connector & Cable	SHEET No. 15 of 19
DOCUMENT NUMBER: PS-76866-001	CREATED / REVISED BY: KBINGHAM	CHECKED BY: TMcCLELLAND	APPROVED BY: TMcCLELLAND



PRODUCT SPECIFICATION

7.2 SIGNAL INTEGRITY REQUIREMENTS (CONNECTOR & CABLE SYSTEM, SAS/SATA)

ITEM	DESCRIPTION	TEST CONDITION	REQUIREMENT
1	Differential Impedance	Rise time of 55 ps (20 % - 80 %)	100 ± 15 ohms (mated cable)
2	Common-mode Impedance	Rise time of 55 ps (20 % - 80 %)	32.5 ± 7.5 ohms (cable)
3	Differential Mode Return Loss	- Measured from 10 MHz < f < 4.5 GHz - Measured from 4.5 GHz < f < 6.5 GHz	≤ -8 dB ≤ -8+16 dB per decade
4	Common Mode Return Loss	Measured from 10 MHz to 6.5 GHz	≤ -5 dB
5	Differential to Common Mode Conversion	- SCD22: 10 MHz < f < 9.0 GHz - SCD21: 10 MHz < f < 9.0 GHz	≤ -26 dB ≤ -20 dB
6	Differential Insertion Loss	Measured from 10 MHz to 6.0 GHz, 10 MHz steps	≥ -24 dB
7	Isolation	Power-sum crosstalk, all Transmit aggressors, and balance of Receive aggressors, Rx0 as victim	-40 dB largest contributor -36 dB total power sum Up to 6000MHz

REVISION: B	ECR/ECN INFORMATION: EC No: 613300 DATE: 2019 / 03 / 06	TITLE: PRODUCT SPECIFICATION iPass+ HD Series R/A External I/O Connector & Cable	SHEET No. 16 of 19
DOCUMENT NUMBER: PS-76866-001	CREATED / REVISED BY: KBINGHAM	CHECKED BY: TMcCLELLAND	APPROVED BY: TMcCLELLAND



PRODUCT SPECIFICATION

8.0 PACKAGING

8.1 CONNECTOR AND CAGE

- 8.1.1 Product shall be packaged in trays per the packaging specification as called out on the applicable assembly print.
- 8.1.2 Packaging shall meet the requirements of and be tested per the packaging specification as called out on the applicable assembly print.

8.2 PLUG AND CABLE ASSEMBLY

- 8.2.1 Product shall be packaged to protect against damage during handling, transit and storage.

REVISION: B	ECR/ECN INFORMATION: EC No: 613300 DATE: 2019 / 03/ 06	TITLE: PRODUCT SPECIFICATION iPass+ HD Series R/A External I/O Connector & Cable	SHEET No. 17 of 19
DOCUMENT NUMBER: PS-76866-001	CREATED / REVISED BY: KBINGHAM	CHECKED BY: TMcCLELLAND	APPROVED BY: TMcCLELLAND



PRODUCT SPECIFICATION

9.0 GAGES AND FIXTURES

Test setup for latitudinal and longitudinal load testing and shell retention testing. Probe is about 6mm in diameter with a full radius nose. The probe is to be placed 25mm from the front edge of the panel and located at the centerline of the plug. Apply load to plug at a rate of 25mm per minute.

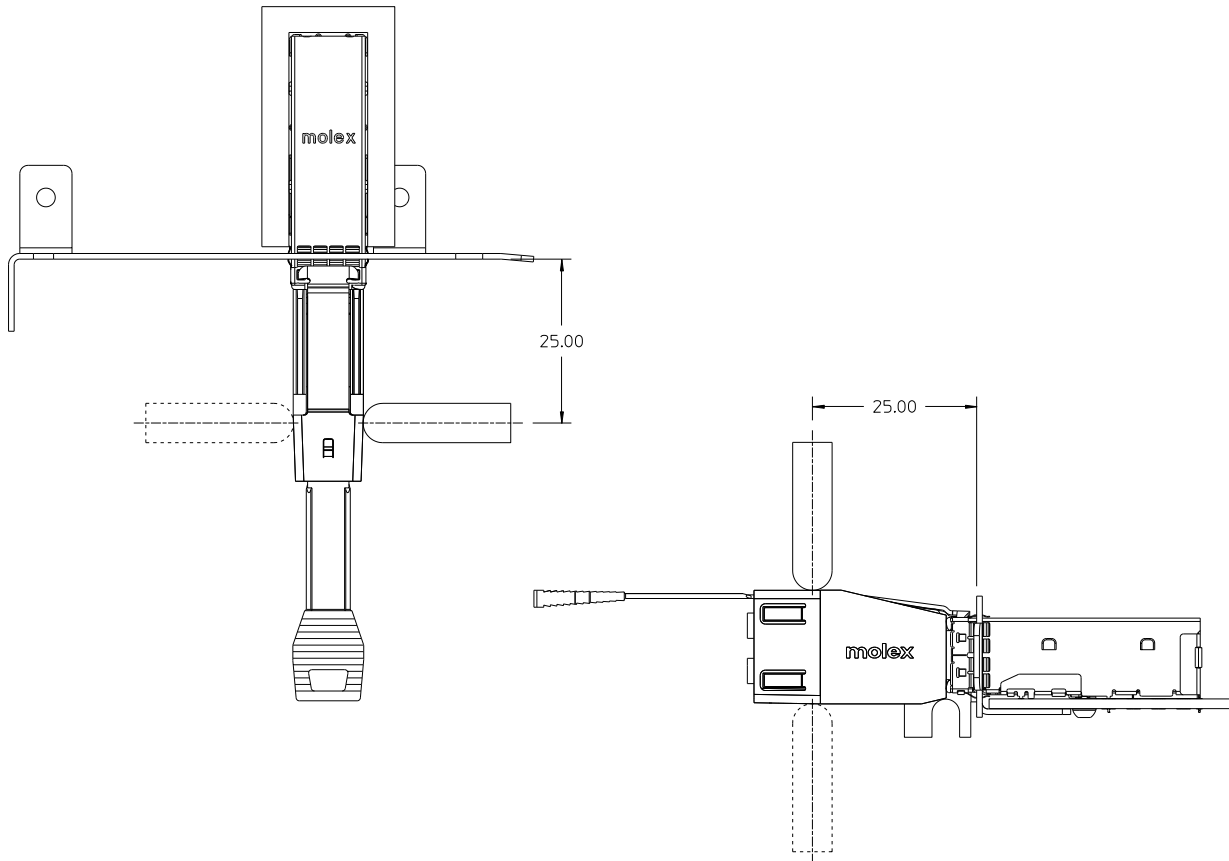

REVISION: B	ECR/ECN INFORMATION: EC No: 613300 DATE: 2019 / 03/ 06	TITLE: PRODUCT SPECIFICATION iPass+ HD Series R/A External I/O Connector & Cable	SHEET No. 18 of 19
DOCUMENT NUMBER: PS-76866-001	CREATED / REVISED BY: KBINGHAM	CHECKED BY: TMcCLELLAND	APPROVED BY: TMcCLELLAND



PRODUCT SPECIFICATION

10.0 OTHER INFORMATION

This page intentionally left blank

REVISION: B	ECR/ECN INFORMATION: EC No: 613300 DATE: 2019 / 03/ 06	TITLE: PRODUCT SPECIFICATION iPass+ HD Series R/A External I/O Connector & Cable	SHEET No. 19 of 19
DOCUMENT NUMBER: PS-76866-001	CREATED / REVISED BY: KBINGHAM	CHECKED BY: TMcCLELLAND	APPROVED BY: TMcCLELLAND