

PART NO.	LENGTH	REF. OVERALL LENGTH (H)
847281002	1.5M (4' 11.06")	1.55M (5 FT 1 1/8 IN)
847281001	2.0M (6' 6.74")	2.05M (6 FT 8 13/16 IN)
847281003	3.0M (9' 10.10")	3.05M (10 FT 3/16 IN)
847281004	5.0M (16' 4.85")	5.05M (16 FT 6 7/8 IN)
847281005	0.15M (0' 5.91")	.20M (0 FT 8 IN)

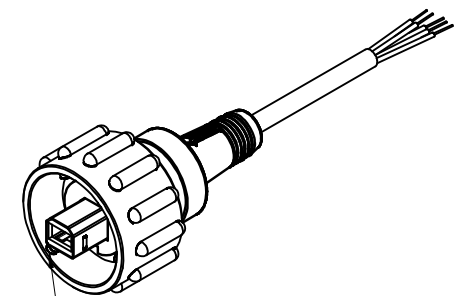
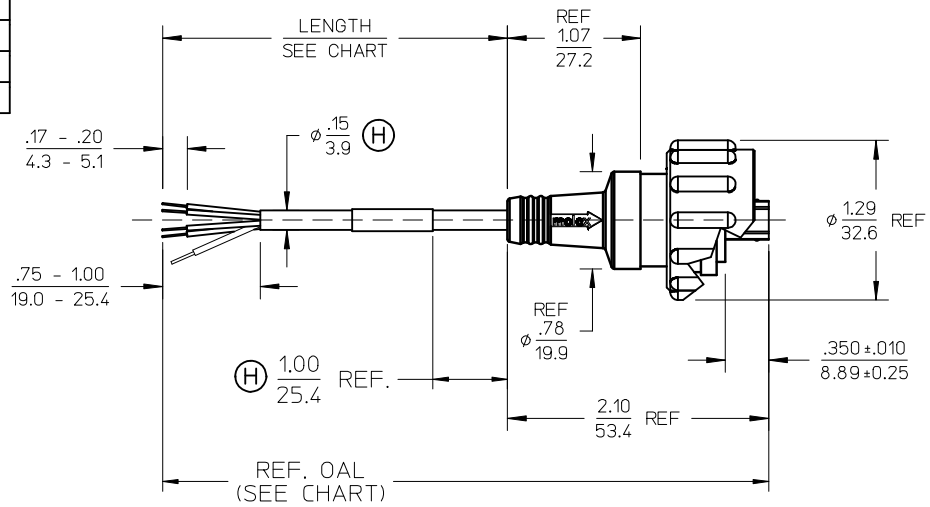

BAYONET STYLE LOCKING INTERFACE

P1

RED	1
WHT	2
GRN	3
BLK	4
DRAIN	

SHIELD

WIRING DIAGRAM

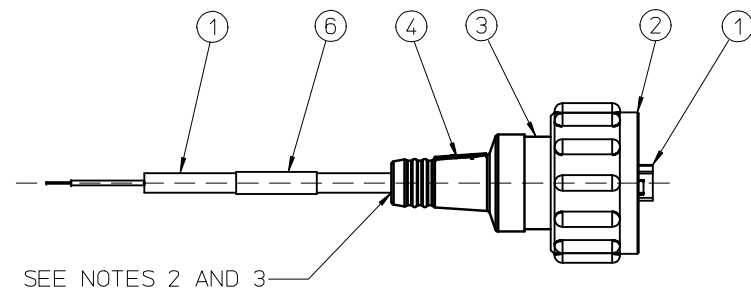

SEE NOTES 2 AND 3

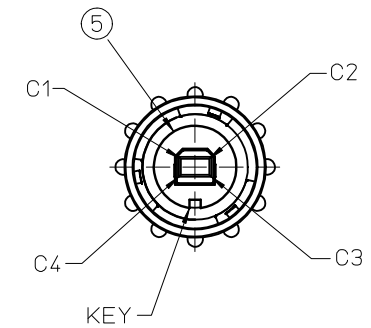

KEY

- (H)
- NOTES: UNLESS OTHERWISE SPECIFIED.
1. MATERIAL: SEE TABLE.
 2. FINISHES: SEE TABLE.
 3. PRODUCT SPEC: PS-84727-002
 4. PACKAGING: SEALED POLY BAG.
 5. MATES WITH: USB TYPE-B RECEPTACLES.
 6. ASSEMBLY IS RoHS COMPLIANT.

ITEM	QTY.	DESCRIPTION	MATERIAL	FINISH
6	1	WRAP LABEL	PLASTIC FILM	BLACK/YELLOW
5	1	GASKET SEAL	NITRILE	BLACK
4	1	OVER MOLDING	PVC	BLACK
3	1	HOLDER	POLYESTER	BLACK
2	1	COUPLING RING	POLYESTER	BLACK
1	1	USB TYPE-A PLUG SHIELDED PIGTAIL	BRASS/PLASTIC	(H)

ADD LABEL, REV'D NOTES EC NO: WNA2010-0029 DR: WAINSTONE 2009/07/13 CHKDK: JOZWIK APPR: J MURPHY 2009/07/20 REV DESCRIPTION	QUALITY SYMBOLS ▽=0 ▽=0	GENERAL TOLERANCES (UNLESS SPECIFIED) mm INCH 4 PLACES ± --- ± --- 3 PLACES ± --- ± .005 2 PLACES ± 0.13 ± .01 1 PLACE ± 0.3 ± --- ANGULAR ± 2 °	DIMENSION STYLE IN/MM DRAWN BY DATE S. GILBERT 06-29-04 CHECKED BY DATE G. ROBERTSON 10-05-04 APPROVED BY DATE AMP 10-05-04	SCALE 1:1 DESIGN UNITS INCH THIRD ANGLE PROJECTION
	DRAFT WHERE APPLICABLE MUST REMAIN WITHIN DIMENSIONS			
	MATERIAL NO. SEE CHART		DOCUMENT NO. SD-84728-001	
	SIZE B		THIS DRAWING CONTAINS INFORMATION THAT IS PROPRIETARY TO MOLEX INCORPORATED AND SHOULD NOT BE USED WITHOUT WRITTEN PERMISSION	