

- NOTES
2. CRIMP FOR 22 TO 26 GA. WIRE WITH MAX. INSULATION DIA. OF (.165)±.065
 3. PLATINGS CONFORM TO MOLEX ENG. STD. SDES-88.
 4. DIMENSIONS GIVEN ACROSS CENTERLINES ARE SYMMETRICAL ABOUT THOSE CENTERLINES WITHIN HALF THE TOTAL TOLERANCE.
 5. PARTS CONFORM TO PRODUCT SPECIFICATION PS-40-02.

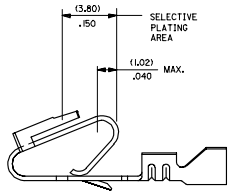

SELECTIVE PLATING AREA

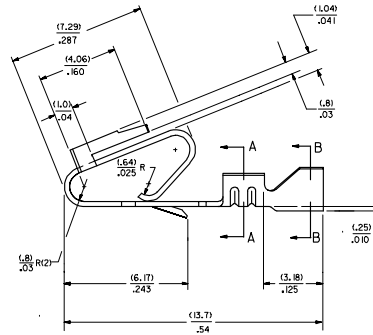
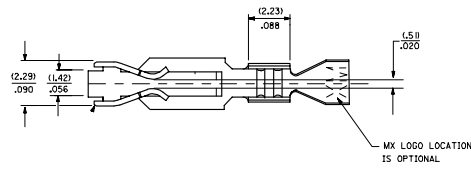
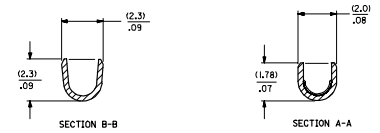
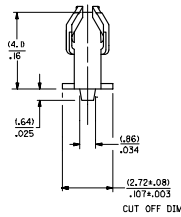

MAT'L: (.27)±.016 THK. J
 BLANK+BRASS
 A=PHOS. BRONZE

7258-1111

FORM
 BLANK+ CHAIN PER DETAIL B
 A=CHAIN PER DETAIL A
 L= LOOSE

PLATING PER SDES- 88

(909) * OVERALL HOT TIN DIP: .00254 MICROMETERS MIN.
 (558) SELECT GOLD: .00016 MICROMETERS MIN.
 OVERALL GOLD FLASH: .00005 MICROMETERS MIN.
 OVERALL NICKEL UNDERPLATE: .00127 MICROMETERS MIN.
 (561) SELECT GOLD: .00076 MICROMETERS MIN.
 OVERALL NICKEL UNDERPLATE: .00127 MICROMETERS MIN.

*THE PRIMARY SHIPPING CARTON WILL BE LABELED "COMPLIANT TO RoHS DIRECTIVE 2002/95/EC AND ELY ANNEX II OF DIRECTIVE 2000/53/EC" CARTONS WITHOUT THIS LABEL MAY CONTAIN PRODUCT WITH TIN-LEAD PLATING.

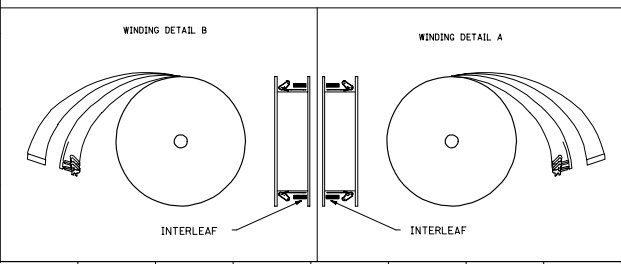

CHANGE TO METO EC INX 12/2005-0964 DRN/BRATNOL 2004/11/19 CHOKSANEK 2008/07/29 APPROVED FOR RELEASE 11	QUALITY SYMBOLS	GENERAL TOLERANCES (UNLESS SPECIFIED)	DIMENSION STYLE	SCALE	DESIGN UNITS	THIRD ANGLE PROJECTION	
	4 PLACES ±.005 3 PLACES ±.010 2 PLACES ±.025 1 PLACE ±.036 ANGULAR ±1/2°	IN/MM INCH IN/MM	DRAWN BY: JJS CHECKED BY: DATE: 12/03/87 DESIGNED BY: DATE: 12/03/87 APPROVED BY: DATE: 12/03/87 MATERIAL NO: LENZ SEE CHART	IN/MM INCH	--- INCH	INCH	TRIFURCON TERMINAL CRIMP TYPE, 156 CENTERS 22 TO 26 AWG MOLEX INCORPORATED DOCUMENT NO: SD-7258 SHEET NO: 1 OF 2
	DRAFT WHERE APPLICABLE MUST REMAIN WITHIN DIMENSIONS	THIS DRAWING CONTAINS INFORMATION THAT IS PROPRIETARY TO MOLEX INCORPORATED AND SHOULD NOT BE USED WITHOUT WRITTEN PERMISSION					

7258-(*)*		7258-A(*)*																			
PART NO.	ENG. NO.	PART NO.	ENG. NO.	PART NO.	ENG. NO.	PART NO.	ENG. NO(SUFFIX ONLY)	PART NO.	ENG. NO(SUFFIX ONLY)	VOID CKT.	PART NO.	ENG. NO(SUFFIX ONLY)	VOID CKT.								
08-50-0183	7258-P909I	08-04-0001	7258-A(999)																		
08-50-0185	7258-AP909IL	08-65-0121	7258-AP56 IL			ES-276-P561															
08-56-0181	7258-1503L	08-65-0122	7258-AP56 IL			MAKE FROM															
08-56-0182	7258-1503L	08-56-0123	7258-AP558I			7258-AP56 IL															
08-50-0283	7258-P909IA	08-56-0124	7258-AP558IL			7258-AP56 IL															
			7258-A(56 I)																		
			7258-A(56 IL)																		
		08-52-0124	7258-AP909I																		
		08-52-0125	7258-AP909IL																		
		08-65-0126	7258-AP555I			ES-276-P555															
		08-65-0127	7258-AP555IL			7258-AP555IL															
		08-58-0133	7258-A(550 I)			MAKE FROM															
		08-58-0134	7258-A(550 IL)			7258-AP555I															

COLUMN NO. 1	CONT. IN COLUMN NO.	SHEET NO.	COLUMN NO. 2	CONT. IN COLUMN NO.	SHEET NO.	COLUMN NO. 3	CONT. IN COLUMN NO.	SHEET NO.	COLUMN NO. 4	CONT. IN COLUMN NO.	SHEET NO.	COLUMN NO. 4	CONT. IN COLUMN NO.	SHEET NO.	COLUMN NO. 4	CONT. IN COLUMN NO.	SHEET NO.
--------------	---------------------	-----------	--------------	---------------------	-----------	--------------	---------------------	-----------	--------------	---------------------	-----------	--------------	---------------------	-----------	--------------	---------------------	-----------

CHANGE TO METO EC NO. ICP2005-0964 DRAWN BY: 2004/11/19 CHECKED BY: 2004/11/19 APPROVED BY: 2004/11/19 DESIGNED BY: 2004/11/19	QUALITY SYMBOLS	GENERAL TOLERANCES (UNLESS SPECIFIED)	DISPOSITION STYLE	SCALE	DESIGN UNITS	THIRD ANGLE PROJECTION
	▽=0	mm INCH	IN/MM	---	INCH	☉
	▽=0	4 PLACES ± --- ± ---	DRAWN BY DATE	JJS 12/07/87	TITLE	TRIFURCON TERMINAL
		3 PLACES ± --- ± ---	CHECKED BY DATE	PATEL 12/07/87		CRIMP TYPE
	2 PLACES ± --- ± ---	APPROVED BY DATE	LENZ 12/07/87	MATERIAL NO.	MOLEX INCORPORATED	
	1 PLACE ± --- ± ---	ANGULAR ±1/2°	SEE CHART	DOCUMENT NO.	SD-7258	SHEET NO. 2
DRAFT WHERE APPLICABLE MUST REMAIN WITHIN DIMENSIONS		THIS DRAWING CONTAINS INFORMATION THAT IS PROPRIETARY TO MOLEX INCORPORATED AND SHOULD NOT BE USED WITHOUT WRITTEN PERMISSION				

Rev. 1	19	18	17	16	15	14	13	12	11	10	9	8	7	6	5	4	3	2	1
--------	----	----	----	----	----	----	----	----	----	----	---	---	---	---	---	---	---	---	---