

CKT SIZE	DIMENSION					
	A	B	C	D	E	F
4	6.65	4.85	2.00	---	---	5.00
6	8.65	6.85	4.00	---	2.00	7.00
8	10.65	8.85	6.00	---	4.00	9.00
10	12.65	10.85	8.00	---	6.00	11.00
12	14.65	12.85	10.00	---	8.00	13.00
14	16.65	14.85	12.00	8.00	10.00	15.00
16	18.65	16.85	14.00	10.00	12.00	17.00
18	20.65	18.85	16.00	12.00	14.00	19.00
20	22.65	20.85	18.00	14.00	16.00	21.00
22	24.65	22.85	20.00	16.00	18.00	23.00
24	26.65	24.85	22.00	18.00	20.00	25.00
26	28.65	26.85	24.00	20.00	22.00	27.00
28	30.65	28.85	26.00	22.00	24.00	29.00
30	32.65	30.85	28.00	24.00	26.00	31.00
32	34.65	32.85	30.00	26.00	28.00	33.00
34	36.65	34.85	32.00	28.00	30.00	35.00
36	38.65	36.85	34.00	30.00	32.00	37.00
38	40.65	38.85	36.00	32.00	34.00	39.00
40	42.65	40.85	38.00	34.00	36.00	41.00
42	44.65	42.85	40.00	36.00	38.00	43.00
44	46.65	44.85	42.00	38.00	40.00	45.00
46	48.65	46.85	44.00	40.00	42.00	47.00
48	50.65	48.85	46.00	42.00	44.00	49.00
50	52.65	50.85	48.00	44.00	46.00	51.00

ADD 34CKT T&R P/N EC NO: S2009-0642 DRWN:SKANG 2009/03/11 CHKD:ATSEE 2009/03/11 APPR:MLONG 2009/03/18	QUALITY SYMBOLS ▽=0 ◻=0	GENERAL TOLERANCES (UNLESS SPECIFIED)		DIMENSION STYLE MM ONLY		SCALE NTS	DESIGN UNITS METRIC	THIRD ANGLE PROJECTION		
				DRAWN BY ATSEE	DATE 2003/10/14	TITLE MGRID, SHROUDED HEADER SMT, W/PEGS/CAP FOR PICK & PLACE IN TUBE AND T&R				
				CHECKED BY KCL ING	DATE 2003/11/07	MOLEX INCORPORATED				
				APPROVED BY SKTOH	DATE 2003/11/07	DOCUMENT NO. SD-87832-007				
A9	REV	DRAFT WHERE APPLICABLE MUST REMAIN WITHIN DIMENSIONS		SEE TABLE		SHEET NO. 1 OF 4				
				SIZE A3	THIS DRAWING CONTAINS INFORMATION THAT IS PROPRIETARY TO MOLEX INCORPORATED AND SHOULD NOT BE USED WITHOUT WRITTEN PERMISSION					

WITH CAP
TUBE PACKAGING

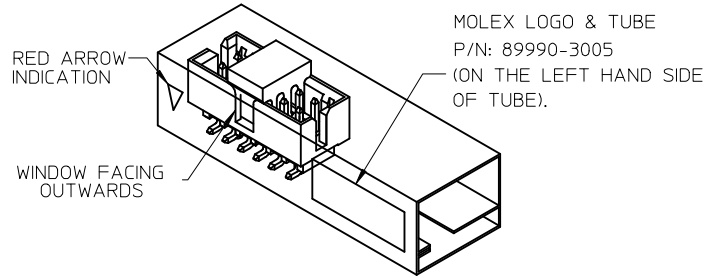
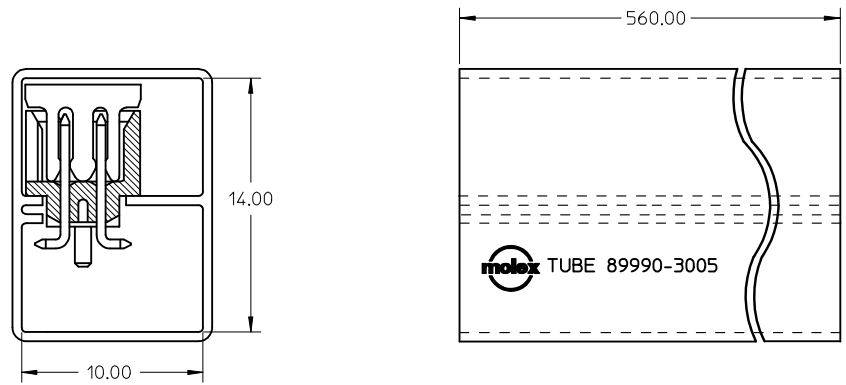

REF : ORIENTATION OF PART IN TUBE,
(FOR THE REFERENCE OF PART/TUBE ASSEMBLY.)

ADD 34CKT T&R P/N EC NO: S2009-0642 DRWN:SKANG 2009/03/11 CHKD:ATSEE 2009/03/11 APPR:MLONG 2009/03/18	DESCRIPTION REV	QUALITY SYMBOLS	GENERAL TOLERANCES (UNLESS SPECIFIED)		DIMENSION STYLE MM ONLY		SCALE NTS	DESIGN UNITS METRIC	THIRD ANGLE PROJECTION		
		▼=0 □=0	mm	INCH	DRAWN BY ATSEE	DATE 2003/10/14	TITLE MGRID, SHROUDED HEADER SMT, W/PEGS/CAP FOR PICK & PLACE IN TUBE AND T&R				
			4 PLACES ± --- ± ---	3 PLACES ± --- ± ---	CHECKED BY KCLING	DATE 2003/11/07	MOLEX INCORPORATED				
			2 PLACES ± 0.2 ± ---	1 PLACE ± --- ± ---	APPROVED BY SKTOH	DATE 2003/11/07	DOCUMENT NO. SD-87832-007				
A9			ANGULAR ± 3 °		MATERIAL NO. SEE TABLE		SHEET NO. 2 OF 4		THIS DRAWING CONTAINS INFORMATION THAT IS PROPRIETARY TO MOLEX INCORPORATED AND SHOULD NOT BE USED WITHOUT WRITTEN PERMISSION		
DRAFT WHERE APPLICABLE MUST REMAIN WITHIN DIMENSIONS											

EMBOSSED CARRIER TAPE LAYOUT OPTION A
24 CKT USE FOR ILLUSTRATION ONLY

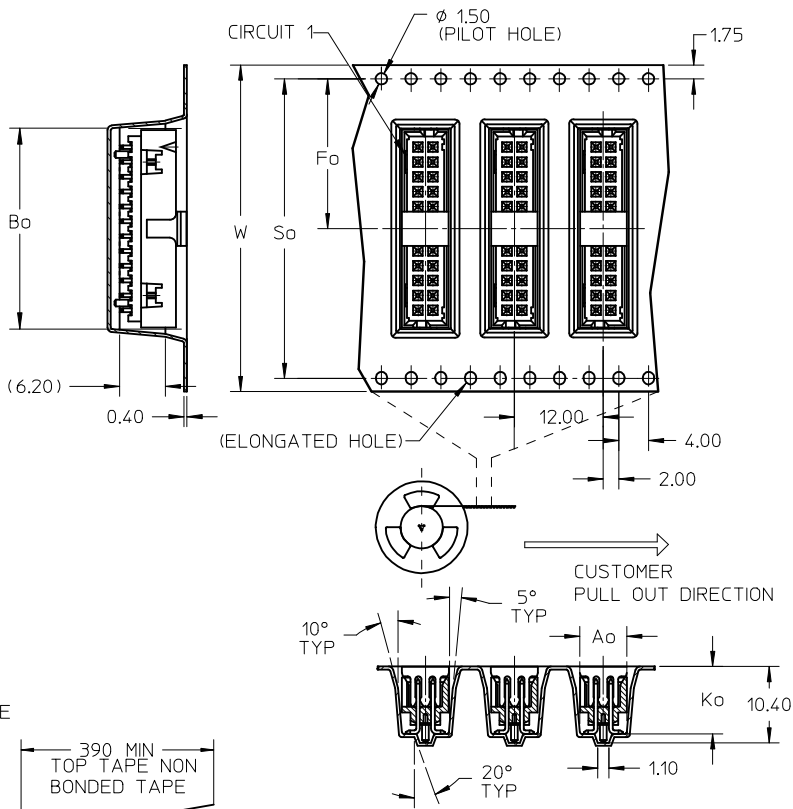

EMBOSSED CARRIER TAPE LAYOUT OPTION B
24 CKT USE FOR ILLUSTRATION ONLY

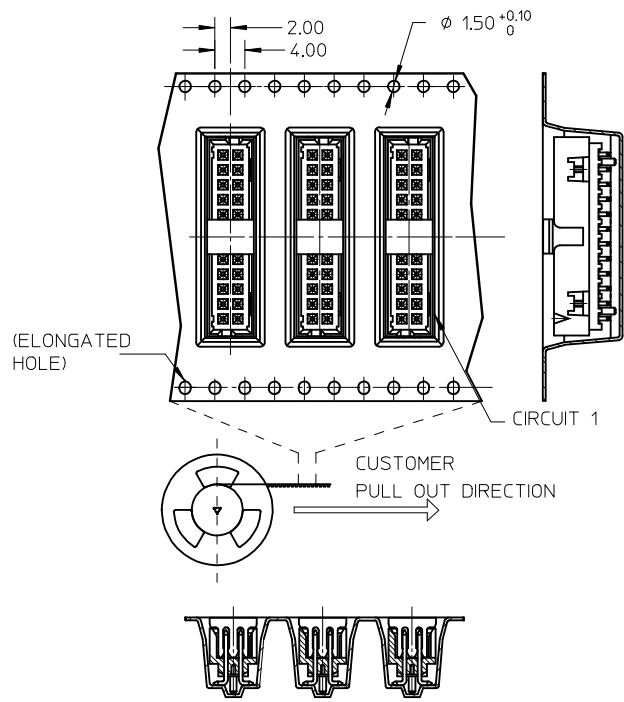

NOTES:

1. LEADER AND TRAILER TAPE

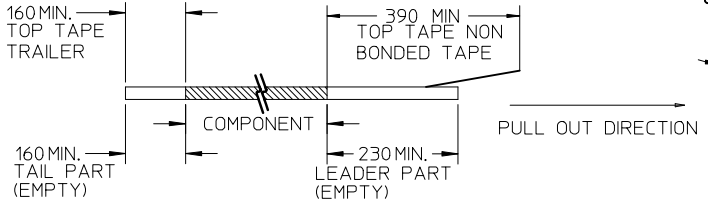

2. PEELING OFF FORCE OF THE TOP TAPE: 20-80gf.
(PEELING DIRECTION AS SHOWN IN FOLLOWING FIGURE)

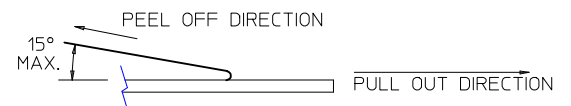

3. PACKAGING STANDARD IS AS PER EIA-481.

ADD 34CKT T&R P/N	2009/03/11	2009/03/11	2009/03/18
EC NO: S2009-0642	DRWN:SKANG	CHKD:ATSEE	APPR:MLONG
REV	DESCRIPTION		
A9			

QUALITY SYMBOLS	▽=0
	∇=0
GENERAL TOLERANCES (UNLESS SPECIFIED)	mm
	INCH
	4 PLACES ± --- ± ---
	3 PLACES ± --- ± ---
	2 PLACES ± 0.2 ± ---
1 PLACE ± --- ± ---	
ANGULAR ± 3 °	
DRAFT WHERE APPLICABLE MUST REMAIN WITHIN DIMENSIONS	

DIMENSION STYLE		SCALE	DESIGN UNITS	THIRD ANGLE PROJECTION
MM ONLY		NTS	METRIC	☉ □
DRAWN BY	DATE	TITLE		
ATSEE	2003/10/14	MGRID, SHROUDED HEADER SMT, W/PEGS/CAP FOR PICK & PLACE IN TUBE AND T&R		
CHECKED BY	DATE	MOLEX INCORPORATED		
KCL ING	2003/11/07	SD-87832-007		
APPROVED BY	DATE	SHEET NO.		
SKTOH	2003/11/07	3 OF 4		
MATERIAL NO.	SEE TABLE	THIS DRAWING CONTAINS INFORMATION THAT IS PROPRIETARY TO MOLEX INCORPORATED AND SHOULD NOT BE USED WITHOUT WRITTEN PERMISSION		

REG OPTION	P/N W/O CAP IN TUBE	P/N W/CAP IN TUBE (SHEET 2)	P/N W/CAP TAPE & REEL (SHEET 3)	CKT SIZE	DIMENSION						PACKAGING OPTION (SHEET 3)
					W	Fo	Bo	So	Ao	Ko	
NO	87832-0421	87832-0423	87832-5123	04	16.00	7.50	7.15	-	6.40	9.30	A
YES	87832-0621	87832-0623	87832-5223	06	24.00	11.50	9.15	-	6.40	9.30	A
YES	87832-0821	87832-0823	87832-5323	08	24.00	11.50	11.05	-	6.40	9.30	A
YES	87832-1021	87832-1023	87832-5423	10	24.00	11.50	13.05	-	6.40	9.30	A
YES	87832-1221	87832-1223	87832-5523	12	32.00	14.20	15.15	28.40	6.40	9.30	A
YES	87832-1421	87832-1423	87832-5623	14	32.00	14.20	17.05	28.40	6.40	9.30	A
YES	87832-1621	87832-1623	87832-5723	16	32.00	14.20	19.05	28.40	6.40	9.30	A
YES	87832-1821	87832-1823	87832-5823	18	44.00	20.20	21.05	40.40	6.40	9.30	A
YES	87832-2021	87832-2023	87832-5923	20	44.00	20.20	23.05	40.40	6.40	9.30	A
YES	87832-2221	87832-2223	87832-6023	22	44.00	20.20	25.05	40.40	6.40	9.30	A
YES	87832-2421	87832-2423	87832-6123	24	44.00	20.20	27.05	40.40	6.40	9.30	A
YES	87832-2621	87832-2623	87832-6223	26	44.00	20.20	29.05	40.40	6.40	9.30	A
YES	87832-2821	87832-2823	87832-6323	28	56.00	26.20	31.05	52.40	6.40	9.30	A
YES	87832-3021	87832-3023	87832-6423	30	56.00	26.20	33.05	52.40	6.40	9.30	A
YES	87832-3221	87832-3223	--	32	--	--	--	--	--	--	-
YES	87832-3421	87832-3423	87832-6623	34	56.00	26.20	37.05	52.40	6.40	9.30	A
YES	87832-3621	87832-3623	--	36	--	--	--	--	--	--	-
YES	87832-3821	87832-3823	--	38	--	--	--	--	--	--	-
YES	87832-4021	87832-4023	87832-6923	40	56.00	26.20	43.05	52.40	6.40	9.30	A
YES	87832-4221	87832-4223	--	42	--	--	--	--	--	--	-
YES	87832-4421	87832-4423	87832-7123	44	56.00	26.20	46.80	52.40	6.40	9.30	A
YES	87832-4621	87832-4623	--	46	--	--	--	--	--	--	-
YES	87832-4821	87832-4823	--	48	--	--	--	--	--	--	-
YES	87832-5021	87832-5023	87832-7423	50	72.00	34.20	53.05	68.40	6.40	9.30	A
YES	--	--	87832-9423	10	24.00	11.50	13.05	-	6.40	9.30	B

PLS REFER TO PART
87832-***09 FOR CENTER
LOCKING SLOT OPTION.

- NOTES:
- FOR ILLUSTRATION PURPOSES, 20 CIRCUIT SIZE WAFER IS SHOWN.
 - MATERIAL :
HOUSING & CAP : 30% G.F., NYLON 46, UL94V-0, COLOR BLACK.
PIN : 0.50MM SQ.PHOSPHOR BRONZE.
 - PLATING : 0.76um/30uin GOLD IN CONTACT AREA AND 1.88um/75uin MIN.TIN
IN SOLDER TAIL AREA OVER 1.27um/50uin MIN. NICKEL OVERALL.
 - PRODUCT SPECIFICATION PS-87831-027 APPLIES.
 - COPLANARITY IS TO BE MEASURED BY RESTING THE SOLDER TAIL
ON A GAUGE SURFACE.
 - NO SIDE LOCKING SLOT FROM 4 TO 12 CKT SIZE.
 - CKT 4 & 6 HAS NO IDENTIFICATION TAG.
 - POSITION OF CAP TO BE LOCATED AT CENTER OF DIMENSION 'A'
REGARDLESS OF CIRCUIT SIZE.
 - TOP SURFACE OF CAP TO BE FLAT FOR THE PURPOSE OF PICK-&-PLACE
BY VACUUM SUCTION NOZZLE.
 - THIS HEADER MATES WITH MOLEX:
a) CRIMP RECEPTACLE HOUSING, 51110 SERIES
WITH CRIMP TERMINAL, 50394 SERIES.
b) 2MM MILLIGRID DUAL ROW IDT, 87568 SERIES.
 - NO CENTRE POLARIZATION SLOT FOR CKT SIZE 4 AND 6.
 - PARTS SHALL BE PACKED IN MOISTURE BARRIER BAG.

ADD 34CKT T&R P/N EC NO: S2009-0642 DRWN:SKANG 2009/03/11 CHKD:ATSEE 2009/03/11 APPR:MLONG 2009/03/18	QUALITY SYMBOLS ▽=0 ◻=0	GENERAL TOLERANCES (UNLESS SPECIFIED)		DIMENSION STYLE MM ONLY		SCALE NTS	DESIGN UNITS METRIC	THIRD ANGLE PROJECTION			
		4 PLACES ± --- ± --- 3 PLACES ± --- ± --- 2 PLACES ± 0.2 ± --- 1 PLACE ± --- ± ---	mm INCH	DRAWN BY ATSEE	DATE 2003/10/14	TITLE MGRID, SHROUDED HEADER SMT, W/PEGS/CAP FOR PICK & PLACE IN TUBE AND T&R					
		ANGULAR ± 3 °		CHECKED BY KCLING	DATE 2003/11/07	MOLEX INCORPORATED					
		DRAFT WHERE APPLICABLE MUST REMAIN WITHIN DIMENSIONS		APPROVED BY SKTOH	DATE 2003/11/07	MATERIAL NO. SEE TABLE	DOCUMENT NO. SD-87832-007	SHEET NO. 4 OF 4			

P/N IN TUBE	PEG OPTION	CKT SIZE
87832-063*	YES	6

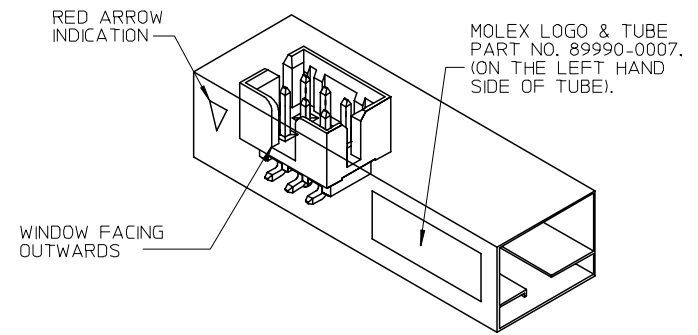
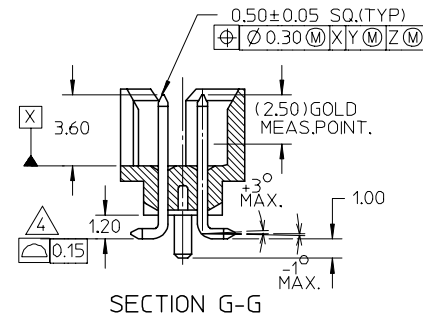
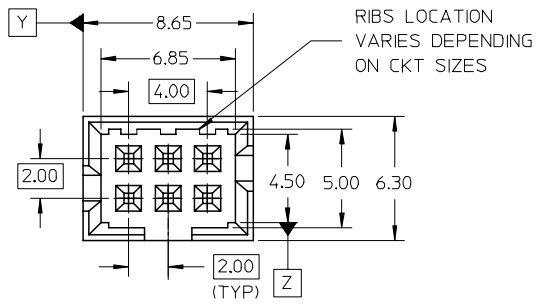

REF : ORIENTATION OF PART IN TUBE.
(FOR THE REFERENCE OF PART/TUBE ASSEMBLY.)

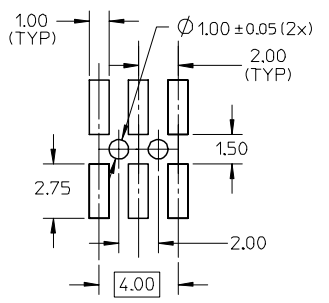
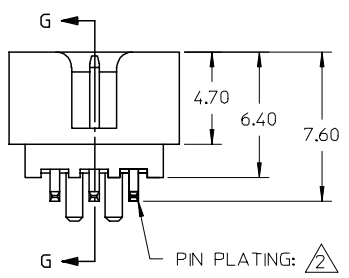

RECOMMENDED PCB PATTERN

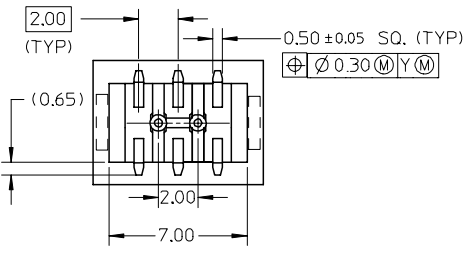

- NOTES:
- MATERIAL :
HOUSING : 30% G.F., NYLON 46, UL94V-0, COLOR BLACK.
PIN : 0.50MM SQ.PHOSPHOR BRONZE.
 - PLATING :
33 - 0.38um/15uin GOLD IN CONTACT AREA AND 1.88um/75uin MIN. TIN IN SOLDER TAIL AREA OVER 1.27um/50uin MIN. NICKEL OVERALL.
34 - 0.76um/30uin GOLD IN CONTACT AREA AND 1.88um/75uin MIN. TIN IN SOLDER TAIL AREA OVER 1.27um/50uin MIN. NICKEL OVERALL.
 - PRODUCT SPECIFICATION PS-87831-027 APPLIES.
 - COPLANARITY IS TO BE MEASURED BY RESTING THE SOLDER TAIL ON A GAUGE SURFACE.
 - BEND DEPRESSION ON SMT TAIL IS ACCEPTABLE SO LONG AS IT DOES NOT AFFECT THE OVERALL COPLANARITY OF THE TAIL.

PART NUMBER LEGEND

87832 - 06 * *
PLATING OPTIONS

REVISED EC NO: S2008-0049 DRWNS:KANG CHKD:ATSEE APPR:MLONG	QUALITY SYMBOLS ▽=0 ◁=0	GENERAL TOLERANCES (UNLESS SPECIFIED)		DIMENSION STYLE MM ONLY	SCALE NTS	DESIGN UNITS METRIC	THIRD ANGLE PROJECTION	
		4 PLACES ± --- ± ---	3 PLACES ± --- ± ---	2 PLACES ± 0.20 ± ---	1 PLACE ± --- ± ---	DRAWN BY ATSEE DATE 2004/10/20		TITLE MGRID, SHROUDED HEADER WITH LOCATING PEGS, SMT
		ANGULAR ± 3 °				CHECKED BY SHONG DATE 2004/11/19		MOLEX INCORPORATED
		DRAFT WHERE APPLICABLE MUST REMAIN WITHIN DIMENSIONS		SEE TABLE		APPROVED BY KCLING DATE 2004/11/19		
A1	REV			SIZE A3	SHEET NO. 1 OF 1			