

Distributed by:

**JAMECO**<sup>®</sup>  
ELECTRONICS

**www.Jameco.com ♦ 1-800-831-4242**

The content and copyrights of the attached  
material are the property of its owner.

Jameco Part Number 1961217



# PRODUCT SPECIFICATION

## TITLE

### 1.0 SCOPE

This Product Specification covers the 2.54 mm (.100 inch) centerline (pitch) 0.64 mm (.025) square pin headers when mated with connectors terminated with 22 to 30 AWG wire using crimp technology.

### 2.0 PRODUCT DESCRIPTION

#### 2.1 PRODUCT NAME AND SERIES NUMBERS

Crimp Terminals: 7879  
Crimp Housings: 7880  
Other products conforming to this specification are noted on the individual drawings.

#### 2.2 DIMENSIONS, MATERIALS, PLATINGS AND MARKINGS

Terminal Material: Brass or Phos. Bronze (for Max performance use phos bronze material.)  
Housing: Nylon, 94V-0, Color: White  
Pins: Brass or Phos. Bronze  
For more information on dimensions, materials, and plating see the individual drawings.

#### 2.3 SAFETY AGENCY APPROVALS

UL File Number ..... E29179  
CSA .....LR19980

### 3.0 APPLICABLE DOCUMENTS AND SPECIFICATIONS

None

### 4.0 RATINGS

#### 4.1 VOLTAGE

250 Volts AC (RMS) {or 176 Volts DC}

#### 4.2 CURRENT AND APPLICABLE WIRES

Current is dependent on wire size, connector size, contact material, plating, ambient temperature, and related factors. Actual current rating is application dependent and should be evaluated for each application.

AWG	Amps (Max)	Outside Insulation Diameter
22	4.00	See Drawings
24	3.75	See Drawings
26	3.50	See Drawings
28	3.00	See Drawings

#### 4.3 TEMPERATURE (ambient + 30° temp rise)

Operating: 0°C to +75°C  
Nonoperating: - 40°C to +105°C

<b>REVISION:</b> <b>G1</b>	<b>EGR/ECN INFORMATION:</b> EC No: <b>UCP2005-2745</b> DATE: <b>2005/06/14</b>	<b>TITLE:</b> <b>PRODUCT SPECIFICATION</b> <b>.100 CENTER KK CONNECTORS</b>	<b>SHEET No.</b> <b>1 of 4</b>
<b>DOCUMENT NUMBER:</b> <b>PS-7879</b>		<b>CREATED / REVISED BY:</b> <b>NDUNNE</b>	<b>CHECKED BY:</b> <b>KSAMIEC</b>
		<b>APPROVED BY:</b> <b>COMERCI</b>	



# PRODUCT SPECIFICATION

## 5.0 PERFORMANCE

### 5.1 ELECTRICAL REQUIREMENTS

DESCRIPTION	TEST CONDITION	REQUIREMENT
Contact Resistance (Low Level)	Mate connectors: apply a maximum voltage of 20 mV and a current of 15 mA.	10 milliohms MAXIMUM [initial]
Contact Resistance of Wire Termination (Low Level)	Terminate the applicable wire to the terminal and measure wire using a voltage of 20 mV and a current of 15 mA.	2 milliohms MAXIMUM [initial]
Insulation Resistance	Unmate & unmount connectors: apply a voltage of 500 VDC between adjacent terminals and between terminals to ground.	1000 Megohms MINIMUM
Dielectric Withstanding Voltage	Unmate connectors: apply a voltage of {two times the rated voltage plus 1000 volts} VAC for 1 minute between adjacent terminals and between terminals to ground.	No breakdown
Capacitance	Measure between adjacent terminals at 1 MHz.	2 picofarads MAXIMUM
Temperature Rise (via Current Cycling)	Mate connectors: measure the temperature rise at the rated current after: 1) 96 hours (steady state) 2) 240 hours (45 minutes ON and 15 minutes OFF per hour) 3) 96 hours (steady state)	Temperature rise: +30°C MAXIMUM

REVISION: <b>G1</b>	EGR/ECN INFORMATION: EC No: <b>UCP2005-2745</b> DATE: <b>2005/06/14</b>	TITLE: <b>PRODUCT SPECIFICATION .100 CENTER KK CONNECTORS</b>	SHEET No. <b>2 of 4</b>
DOCUMENT NUMBER: <b>PS-7879</b>	CREATED / REVISED BY: <b>NDUNNE</b>	CHECKED BY: <b>KSAMIEC</b>	APPROVED BY: <b>COMERCI</b>



# PRODUCT SPECIFICATION

## 5.2 MECHANICAL REQUIREMENTS

DESCRIPTION	TEST CONDITION	REQUIREMENT
Connector Mate and Unmate Forces	Per circuit when mated to an .025 Sq. pin. Mate and unmate connector (male to female) at a rate of 25 ± 6 mm (1 ± ¼ inch) per minute.	4.6 N (1.0 lbf) MAXIMUM insertion force & 0.8 N (0.22 lbf) MINIMUM withdrawal force
Terminal Insertion Force (into Housing)	Apply an axial insertion force on the terminal at a rate of 25 ± 6 mm (1 ± ¼ inch).	6.67 N (1.5 lbf) MAXIMUM insertion force
Terminal Retention Force (in Housing)	Axial pullout force on the terminal in the housing at a rate of 25 ± 6 mm (1 ± ¼ inch) per minute.	17.8 N (4.0 lbf) MINIMUM withdrawal force
Durability	Mate connectors up to 25 cycles at a maximum rate of 5 cycles per minute prior to Environmental Tests.	10 milliohms MAXIMUM (change from initial)
Vibration (Random)	Mate connectors and vibrate per EIA 364-28, test condition VII.	10 milliohms MAXIMUM (change from initial) & Discontinuity < 1 microsecond
Shock (Mechanical)	Mate connectors and shock at 50 g's with ½ sine wave (11 milliseconds) shocks in the ±X,±Y,±Z axes (18 shocks total).	10 milliohms MAXIMUM (change from initial) & Discontinuity < 1 microsecond
Wire Pullout Force (Axial)	Apply an axial pullout force on the wire at a rate of 25 ± 6 mm (1 ± ¼ inch). (When terminated using Molex Application Tooling.)	24 awg = 35 N (8 lbf) 26 awg = 26 N (6 lbf) 28 awg = 17 N (4 lbf) 30 awg = 13 N (3 lbf)
Normal Force	Apply a perpendicular force.	6.28 N (640 grams) average

REVISION: <b>G1</b>	EGR/ECN INFORMATION: EC No: <b>UCP2005-2745</b> DATE: <b>2005/06/14</b>	TITLE: <b>PRODUCT SPECIFICATION .100 CENTER KK CONNECTORS</b>	SHEET No. <b>3 of 4</b>
DOCUMENT NUMBER: <b>PS-7879</b>	CREATED / REVISED BY: <b>NDUNNE</b>	CHECKED BY: <b>KSAMIEC</b>	APPROVED BY: <b>COMERCI</b>



# PRODUCT SPECIFICATION

## 5.3 ENVIRONMENTAL REQUIREMENTS

DESCRIPTION	TEST CONDITION	REQUIREMENT										
Shock (Thermal)	Mate connectors; expose to 5 cycles of: <table border="1"> <thead> <tr> <th>Temperature °C</th> <th>Duration (Minutes)</th> </tr> </thead> <tbody> <tr> <td>-40 +0/-3</td> <td>30</td> </tr> <tr> <td>+25 ±10</td> <td>5 MAXIMUM</td> </tr> <tr> <td>+105 +3/-0</td> <td>30</td> </tr> <tr> <td>+25 ±10</td> <td>5 MAXIMUM</td> </tr> </tbody> </table>	Temperature °C	Duration (Minutes)	-40 +0/-3	30	+25 ±10	5 MAXIMUM	+105 +3/-0	30	+25 ±10	5 MAXIMUM	10 milliohms MAXIMUM (change from initial) & Visual: No Damage
Temperature °C	Duration (Minutes)											
-40 +0/-3	30											
+25 ±10	5 MAXIMUM											
+105 +3/-0	30											
+25 ±10	5 MAXIMUM											
Thermal Aging	Mate connectors; expose to: 96 hours at 105 ± 2°C	10 milliohms MAXIMUM (change from initial]) & Visual: No Damage										
Humidity (Steady State)	Mate connectors: expose to a temperature of 40 ± 2°C with a relative humidity of 90-95% for 96 hours.  Note: Remove surface moisture and air dry for 1 hour prior to measurements.	10 milliohms MAXIMUM (change from initial) & Dielectric Withstanding Voltage: No Breakdown at 500 VAC & Insulation Resistance: 1000 Megohms MINIMUM & Visual: No Damage										
Humidity (Cyclic)	Mate connectors: cycle per EIA-364-31: 24 cycles at temperature 25 ± 3°C at 80 ± 5% relative humidity and 65 ± 3°C at 50 ± 5% relative humidity; dwell time of 1.0 hour; ramp time of 0.5 hours.  {Note: Remove surface moisture and air dry for 1 hour prior to measurements.}	10 milliohms MAXIMUM (change from initial) & Dielectric Withstanding Voltage: No Breakdown at 500 VAC & Insulation Resistance: 1000 Megohms MINIMUM & Visual: No Damage										
Solderability	Per SMES-152	Solder coverage: 95% MINIMUM (per SMES-152)										

## 6.0 PACKAGING

Parts shall be packaged to protect against damage during handling, transit and storage.

## 7.0 GAGES AND FIXTURES

## 8.0 OTHER

REVISION: <b>G1</b>	EGR/ECN INFORMATION: EC No: <b>UCP2005-2745</b> DATE: <b>2005/06/14</b>	TITLE: <b>PRODUCT SPECIFICATION .100 CENTER KK CONNECTORS</b>	SHEET No. <b>4 of 4</b>
DOCUMENT NUMBER: <b>PS-7879</b>	CREATED / REVISED BY: <b>NDUNNE</b>	CHECKED BY: <b>KSAMIEC</b>	APPROVED BY: <b>COMERCI</b>

NO. OF CKT'S.	DIM. A	DIM. B
1		.122±.010 (3.10±.25)
2	.100±.004 (2.54±.10)	.222±.010 (5.64±.25)
3	.200±.004 (5.08±.10)	.322±.010 (8.18±.25)
4	.300±.004 (7.62±.10)	.422±.010 (10.72±.25)
5	.400±.004 (10.16±.10)	.522±.010 (13.26±.25)
6	.500±.005 (12.70±.13)	.622±.010 (15.80±.25)
7	.600±.005 (15.24±.13)	.722±.011 (18.34±.28)
8	.700±.005 (17.78±.13)	.822±.011 (20.88±.28)
9	.800±.006 (20.32±.15)	.922±.011 (23.42±.28)
10	.900±.006 (22.86±.15)	1.022±.012 (25.96±.30)
11	1.000±.006 (25.40±.15)	1.122±.012 (28.50±.30)
12	1.100±.006 (27.94±.15)	1.222±.012 (31.04±.30)
13	1.200±.007 (30.48±.18)	1.322±.012 (33.58±.30)
14	1.300±.007 (33.02±.18)	1.422±.013 (36.12±.33)
15	1.400±.011 (35.56±.28)	1.522±.013 (38.66±.33)
16	1.500±.011 (38.10±.28)	1.622±.013 (41.20±.33)
17	1.600±.011 (40.64±.28)	1.722±.013 (43.74±.33)
18	1.700±.011 (43.18±.28)	1.822±.014 (46.28±.36)
19	1.800±.011 (45.72±.28)	1.922±.014 (48.82±.36)
20	1.900±.011 (48.26±.28)	2.022±.014 (51.36±.36)
21	2.000±.012 (50.80±.30)	2.122±.015 (53.90±.38)
22	2.100±.012 (53.34±.30)	2.222±.015 (56.44±.38)
23	2.200±.012 (55.88±.30)	2.322±.015 (58.98±.38)
24	2.300±.012 (58.42±.30)	2.422±.016 (61.52±.41)
25	2.400±.013 (60.96±.33)	2.522±.016 (64.06±.41)
26	2.500±.013 (63.50±.33)	2.622±.016 (66.60±.41)
27	2.600±.013 (66.04±.33)	2.722±.016 (69.14±.41)
28	2.700±.013 (68.58±.33)	2.822±.017 (71.68±.43)

NOTES:

1. DIMENSIONS GIVEN ACROSS CENTERLINES ARE SYMMETRICAL ABOUT THOSE CENTERLINES WITHIN HALF THE TOTAL TOLERANCES.
2. THIS HOUSING FOR USE WITH SHROUDED TERMINAL 7879.
3. THIS PRODUCT COMPLIES WITH MOLEX PRODUCT SPEC. NO. 7879.
4. SPECIAL SUPPORT MAY BE REQUIRED FOR PRINTED CIRCUIT BOARDS USED WITH 10 OR MORE CIRCUIT CONNECTORS.
5. INSERTION AND WITHDRAWL FORCES RANGE FROM 1.3 TO 1.9 POUNDS PER CIRCUIT.

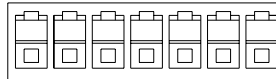
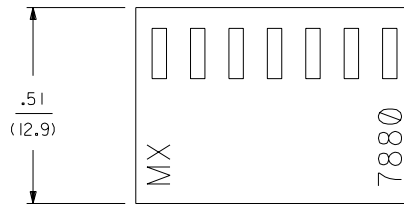
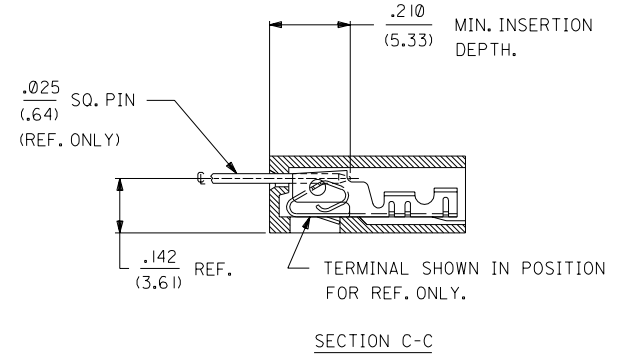
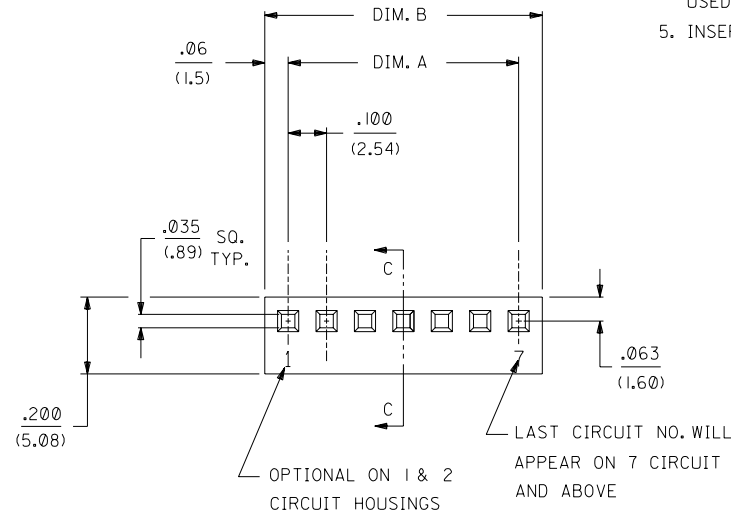

7880 - N \* - \*

NO. OF CKTS.

VOID CODE  
NO. CORRESPONDS TO  
CKT. NO. VOIDED.  
MULT. VOIDS START WITH 51.

OPTION CODE		
OPT. CODE	RAMP	MATERIAL
A	NONE	NYLON, 94V-0, COLOR-WHITE
B	STD. RAMP	NYLON, 94V-0, COLOR-WHITE
C	POL. RAMP	NYLON, 94V-0, COLOR-WHITE

DIMENSIONS SHOWN (METRIC) INCH UNLESS OTHERWISE SPECIFIED TOLERANCES: ANGULAR ± 1/2°		▽ = 0	▼ = 0	REVISE ONLY ON CAD SYSTEM
3 PLACE ± .010		INCH		TITLE (2.54)/.100 KK, HOUSING FOR SHROUDED CRIMP TYPE TERMINAL
2 PLACE ± .014 ± 0.25		METRIC		
1 PLACE --- ± 0.35				
DRAWING WHERE APPLICABLE MUST REMAIN WITHIN DIMENSIONS				MOLEX INCORPORATED LITSE,ILL. 60532 U.S.A.
PART NO. SD-7880		SHEET NO. 1 OF 2		DATE 08/24/88
DRAWN BY GUZIK		CHK'D BY PATEL		FILE NAME SEE CHART
APP'D BY LENZ		SCALE :		THIS DRAWING CONTAINS INFORMATION THAT IS PROPRIETARY TO MOLEX INC. AND SHOULD NOT BE USED WITHOUT WRITTEN PERMISSION.
LTR.	REVISIONS	LTR.	REVISIONS	MFG. SH. REV.
				2 L
				1 L I

7880-NA-*			7880-NB-*			7880-NC-*		
PART NO.	ENG. NO.	VOID CKT.	PART NO.	ENG. NO.	VOID CKT.	PART NO.	ENG. NO.	VOID CKT.
10-01-2019	7880-1A		10-11-2013	7880-1B		N/A	7880-1C	
10-01-2029	7880-2A		10-11-2023	7880-2B		10-11-2024	7880-2C	
10-01-2039	7880-3A		10-11-2033	7880-3B		10-11-2034	7880-3C	
10-01-2049	7880-4A		10-11-2043	7880-4B		10-11-2044	7880-4C	
10-01-2059	7880-5A		10-11-2053	7880-5B		10-11-2054	7880-5C	
10-01-2069	7880-6A		10-11-2063	7880-6B		10-11-2064	7880-6C	
10-01-2079	7880-7A		10-11-2073	7880-7B		10-11-2074	7880-7C	
10-01-2089	7880-8A		10-11-2083	7880-8B		10-11-2084	7880-8C	
10-01-2099	7880-9A		10-11-2093	7880-9B		10-11-2094	7880-9C	
10-01-2109	7880-10A		10-11-2103	7880-10B		10-11-2104	7880-10C	
10-01-2119	7880-11A		10-11-2113	7880-11B		10-11-2114	7880-11C	
10-01-2129	7880-12A		10-11-2123	7880-12B		10-11-2124	7880-12C	
10-01-2139	7880-13A		10-11-2133	7880-13B		10-11-2134	7880-13C	
10-01-2149	7880-14A		10-11-2143	7880-14B		10-11-2144	7880-14C	
10-01-2159	7880-15A		10-11-2153	7880-15B		10-11-2154	7880-15C	
10-01-2169	7880-16A		10-11-2163	7880-16B		10-11-2164	7880-16C	
10-01-2179	7880-17A		10-11-2173	7880-17B		10-11-2174	7880-17C	
10-01-2189	7880-18A		10-11-2183	7880-18B		10-11-2184	7880-18C	
10-01-2199	7880-19A		10-11-2193	7880-19B		10-11-2194	7880-19C	
10-01-2209	7880-20A		10-11-2203	7880-20B		10-11-2204	7880-20C	
10-01-2219	7880-21A		10-11-2213	7880-21B		10-11-2214	7880-21C	
10-01-2229	7880-22A		10-11-2223	7880-22B		10-11-2224	7880-22C	
10-01-2239	7880-23A		10-11-2233	7880-23B		10-11-2234	7880-23C	
10-01-2249	7880-24A		10-11-2243	7880-24B		10-11-2244	7880-24C	
10-01-2259	7880-25A		10-11-2253	7880-25B		10-11-2254	7880-25C	
10-01-2269	7880-26A		10-11-2263	7880-26B		10-11-2264	7880-26C	
10-01-2279	7880-27A		10-11-2273	7880-27B		10-11-2274	7880-27C	
10-01-2289	7880-28A		10-11-2283	7880-28B		10-11-2284	7880-28C	
			10-11-2052	7880-5B-2	2			
			10-11-2092	7880-9B-2	2			
			10-11-2105	7880-10B-4	4			

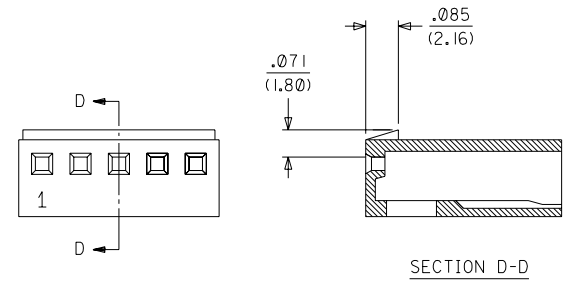

7880-NB-  
STD. RAMP OPTION

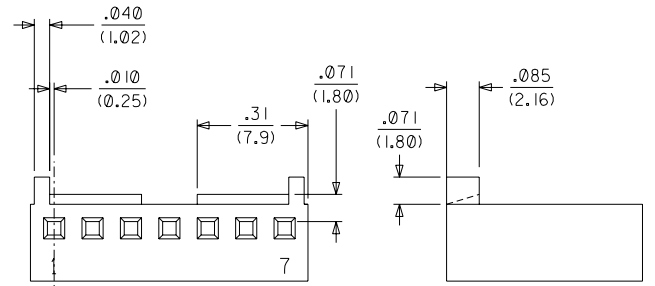

7880-NC-  
POLARIZING RAMP OPTION

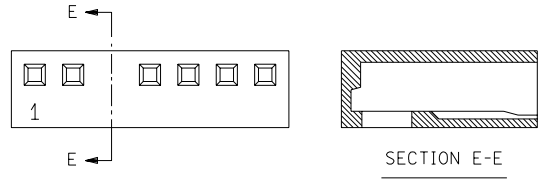

STD. VOID OPTION  
(VOIDS NOT AVAILABLE IN FIRST OR LAST CKT.)

SEE SHEET I	SEE SHEET I	DIMENSIONS SHOWN (METRIC) INCH UNLESS OTHERWISE SPECIFIED TOLERANCES: ANGULAR ± 1/2° INCH METRIC 3 PLACE ± .010 ± 0.25 2 PLACE ± .014 ± 0.25 1 PLACE ± .036 ± 0.36 DRAFT WHERE APPLICABLE MUST REMAIN WITHIN DIMENSIONS DRWG. BY GUZIK CHK'D BY PATEL APP'D BY LENZ SCALE :	∇ = 0 ▼ = 0 REVISE ONLY ON CAD SYSTEM TITLE (2.54)/.100 KK, HOUSING FOR SHROUDED CRIMP TYPE TERMINAL MOLEX INCORPORATED LITSE,ILL. 60532 U.S.A. SHEET NO. 2 DATE 08/24/88 PART NO. SEE CHART DRWG. NO. SD-7880
SEE SHEET I	SEE SHEET I		
SEE SHEET I	SEE SHEET I		
SEE SHEET I	SEE SHEET I		
SEE SHEET I	SEE SHEET I		
SEE SHEET I	SEE SHEET I		
LTR. REVISIONS	LTR. REVISIONS	THIS DRAWING CONTAINS INFORMATION THAT IS PROPRIETARY TO MOLEX INC. AND SHOULD NOT BE USED WITHOUT WRITTEN PERMISSION DIV. SIZE C	