

Distributed by:



www.Jameco.com ♦ 1-800-831-4242

The content and copyrights of the attached material are the property of its owner.

Jameco Part Number 522431

FEATURES AND SPECIFICATIONS

Features and Benefits

- Intermateable, intermountable and interchangeable with industry-standard versions
- Cross tested to assure industry compatibility
- Positive locks
- Fully isolated contacts

Reference Information

Product Specification: PS-42022-0001
 Packaging: Tray
 UL File No.: E29179
 CSA File No.: LR19980
 Designed In: Inches

Electrical

Voltage: 600V
 Current:

Circuit	2	3	4	6	9	12	15
Amperes	13.5	13.5	13.5	11.0	11.0	11.0	11.0

Contact Resistance: 3.5mΩ max.
 Dielectric Withstanding Voltage: 2900V
 Insulation Resistance: 1000 MΩ min.

Physical

Header Housing: See Table
 Header Contact: Phosphor Bronze
 Plating: Tin
 Operating Temperature: -55 to +105°C



**2.13mm (.084") Diameter
 MLX
 Power Connector
 Header**

**42002
 Vertical**

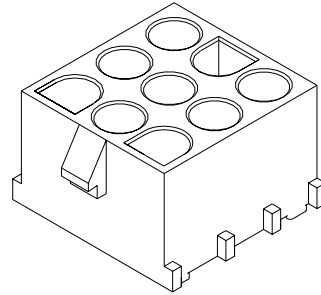

CATALOG DRAWING (FOR REFERENCE ONLY)

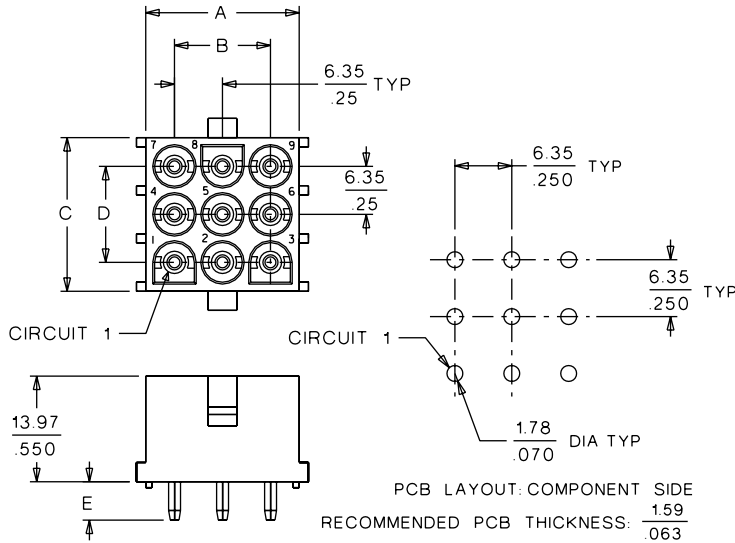

ORDERING INFORMATION AND DIMENSIONS

Circuits	Order No.				Housing	Dimension				
	White		Brick Red			A	B	C	D	E
	Male	Female	Male	Female						
2	• 10-84-4020	• 10-84-4022			94V-2	7.62 (.300)		13.97 (.550)	6.35 (.250)	4.30 (.170)
	10-84-5020	10-84-5021	• 10-84-4021	• 10-84-4023	94V-0					
3	• 10-84-4030	• 10-84-4032			94V-2	7.62 (.300)		20.32 (.800)	12.70 (.500)	4.30 (.170)
	10-84-5030	10-84-5031	• 10-84-4031	• 10-84-4033	94V-0					
4	• 10-84-4040	• 10-84-4042			94V-2	7.62 (.300)		26.67 (1.050)	19.05 (.750)	4.30 (.170)
	10-84-5040	10-84-5041	• 10-84-4041	• 10-84-4043	94V-0					
6	• 10-84-4060	• 10-84-4062			94V-2	20.32 (.800)	12.70 (.500)	13.97 (.550)	6.35 (.250)	4.30 (.170)
	10-84-5060	10-84-5061	• 10-84-4061	• 10-84-4063	94V-0					
9	• 10-84-4090	• 10-84-4092			94V-2	20.32 (.800)	12.70 (.500)	20.32 (.800)	12.70 (.500)	4.30 (.170)
	10-84-5090	10-84-5091	• 10-84-4091	• 10-84-4093	94V-0					
12	• 10-84-4120	• 10-84-4122			94V-2	20.32 (.800)	12.70 (.500)	26.67 (1.050)	19.05 (.750)	4.30 (.170)
	10-84-5120	10-84-5121	• 10-84-4121	• 10-84-4123	94V-0					
15	• 10-84-4150	• 10-84-4152			94V-2	20.32 (.800)	12.70 (.500)	33.02 (1.300)	25.40 (1.000)	4.30 (.170)
	10-84-5150	10-84-5151	• 10-84-4151	• 10-84-4153	94V-0					

• US Standard Product, available through Molex franchised distributors



PRODUCT SPECIFICATION
FOR .084/(2.13) DIAMETER SERIES
PIN AND SOCKET HEADER ASSEMBLIES

(HOT TIN PLATED TERMINALS ONLY)

1.0 Scope:

This specification covers the .250 inch (6.35 mm) centerline tin plated printed circuit board connector series.

2.0 Product Description:

2.1 Product Name and Part Number

Product Name	Part Number
Pin header assembly, 2 circuit	A-42002-2*1A*
Pin header assembly, 3 circuit	A-42002-3*1A*
Pin header assembly, 4 circuit	A-42002-4*1A*
Pin header assembly, 6 circuit	A-42002-6*1A*
Pin header assembly, 9 circuit	A-42002-9*1A*
Pin header assembly, 12 circuit	A-42002-12*1A*
Pin header assembly, 15 circuit	A-42002-15*1A*

Socket header assembly, 2 circuit	A-42002-2*1A*
Socket header assembly, 3 circuit	A-42002-3*1A*
Socket header assembly, 4 circuit	A-42002-4*1A*
Socket header assembly, 6 circuit	A-42002-6*1A*
Socket header assembly, 9 circuit	A-42002-9*1A*
Socket header assembly, 12 circuit	A-42002-12*1A*
Socket header assembly, 15 circuit	A-42002-15*1A*

2.2 Mating components

Housing: Plug	42021-*
Terminal: Pin	42023-1A1*
Terminal: Socket	42024-A1*

2.3 Printed circuit board

Solder tail length:

- For a .062/(1.57) thick board, the .17/(4.3) solder tail length is recommended.
- For a .125/(3.18) thick board, the .23/(4.3) solder tail length is recommended.

2.4 Materials, Platings and Markings

See the appropriate Sales Drawings for information on materials, platings and markings

DRWG. NO.
PSX-42002-0001

DRWG. NO.
PSX-42002-0001

REV.	2	2	2	2	2
SHT.	1	2	3	4	5

FILE NAME PS42002X1	=	=
------------------------	---	---

REVISE ONLY ON CAD SYSTEM

REV. 2

DGN

THIS DRAWING CONTAINS INFORMATION THAT IS PROPRIETARY TO MOLEX INC. AND SHOULD NOT BE USED WITHOUT WRITTEN PERMISSION.

SHT. 1 OF 5



PRODUCT SPECIFICATION
FOR .084/(2.13) DIAMETER SERIES
PIN AND SOCKET HEADER ASSEMBLIES

(HOT TIN PLATED TERMINALS ONLY)

3.0 Applicable Documents and Specifications:
See the Sales Drawings and the other sections of this Specification.

3.1 Agency approvals:
UL file number: applied for
CSA file number: applied for

4.0 Ratings:

It is standard practice in the industry to rate header connector systems the same as in-line connector systems. All the below listed ratings and tests are valid, but it is possible that certain practices and materials of printed circuit board technology will undermine the below listed values, and as such are out of our control. It's the responsibility of the end user to determine the suitability of these products for the application.

4.1 Voltage: 600 Volts
4.2 Current: 12.0 Amps Maximum (under ideal conditions)
4.3 Temperature: Operating - 55 C to + 105 C

5.0 Performance Specifications
5.1 Electrical Performance

ITEM	TEST CONDITION	REQUIREMENT
Contact Resistance [Low Level]	Mate connectors with a maximum voltage of 20 mV and a current of 100 mA (MIL-STD-1344A METHOD 3004.1)	2.5 milliohms Maximum (initial)
Insulation Resistance	Mate connectors with a voltage of 500 VDC between adjacent terminals. (MIL-STD-1344A METHOD 3003.1)	1000 Megohms Minimum (initial)
Dielectric Strength	Mate connectors with a voltage of 2900 VAC for 1 minute between adjacent terminals. (MIL-STD-1344A METHOD 3001.1)	No Breakdown

DRWG. NO. PSX-42002-0001

DRWG. NO. PSX-42002-0001

REV.
SHT.

FILE NAME
PS42002X2
DGN

▽ = ▽ =

REVISE ONLY ON CAD SYSTEM

REV. 2
SHT. 2

THIS DRAWING CONTAINS INFORMATION THAT IS PROPRIETARY TO MOLEX INC. AND SHOULD NOT BE USED WITHOUT WRITTEN PERMISSION.



PRODUCT SPECIFICATION
FOR .084/(2.13) DIAMETER SERIES
PIN AND SOCKET HEADER ASSEMBLIES

(HOT TIN PLATED TERMINALS ONLY)

5.2 Mechanical Performance

ITEM	TEST CONDITION	REQUIREMENT	
		MAX	Min
Connector Insertion and Withdrawal	Insert and withdraw connectors at a rate of 0.5 inches per minute (12.7 mm per minute) (MIL-STD-1344A METHOD 2013.1)	INSERTION 3.0	WITHDRAWAL 0.5 (per terminal, initial)
Retention Force in Housing	Axial push out force on the terminal in the housing at a rate of .5 inches per minute (12.7 mm per minute) (MIL-STD-1344A METHOD 2010.1)	4 lbf	Minimum
Durability	Mate connectors up to 50 cycles at a maximum rate of 5 cycles per minute (MIL-STD-1344A METHOD 2016)	2.6 million	Max
Vibration	Amplitude: .060" (1.5 mm) peak to peak Sweep: 10-55-10 Hertz in one minute Duration: 2 hours in each X-Y-Z axis (MIL-STD-1344A METHOD 2005.1) (TEST CONDITION I)	Appearance: No Damage Contact Resistance: 5.0 milliohm Maximum Discontinuity: 1 micro second Maximum	
Mechanical Shock	50 G's with three shocks in each X-Y-Z axis (MIL-STD-1344A METHOD 2004.1) (TEST CONDITION A)	Appearance: No Damage Contact Resistance: 6 milliohm Maximum Discontinuity: 1 micro second Maximum	

DRWG. NO.
PSX-42002-0001

DRWG. NO.
PSX-42002-0001

REV.
SHT.

FILE NAME PS42002X3	= =	REVISE ONLY ON CAD SYSTEM	REV.	2
DGN	THIS DRAWING CONTAINS INFORMATION THAT IS PROPRIETARY TO MOLEX INC. AND SHOULD NOT BE USED WITHOUT WRITTEN PERMISSION.		SHT.	3



PRODUCT SPECIFICATION
FOR .084/(2.13) DIAMETER SERIES
PIN AND SOCKET HEADER ASSEMBLIES

(HOT TIN PLATED TERMINALS ONLY)

5.3 Environmental Performance

ITEM	TEST CONDITION	REQUIREMENT
Thermal Shock	Mate connectors exposed for 25 cycles of: Temperature Duration -55 +0/-3 C 30 minutes 85 +3/0 C 30 minutes (MIL-STD-1344A METHOD 1003.1) (TEST CONDITION A-1)	Appearance: No Damage Contact Resistance: 12.0 milliohm Maximum Dielectric strength: 2900 Vac for 1 minute
Humidity-temperature cycling	Mate connectors and expose to Temperature -humidity cycling between 25 c and 65 c at 95% RH, -10 c with humidity not controlled (MIL-STD-1344A METHOD 1002.1) (TYPE II)	Appearance: No Damage Contact Resistance: 6.00 milliohm Maximum Dielectric Strength: 5000 VAC for 1 minute Insulation Resistance: 100 Megohms Minimum
Salt spray	Expose unmated connector assemblies to a salt spray concentration of 5% at 35 C for 48 hours. (MIL-STD-1344A METHOD 1001.1)	7.00 milliohm Maximum Dielectric Strength: 5000 VAC for 1 minute
Thermal Aging	Mate connectors exposed for 96 hours at 105 +/- 2 C (MIL-STD-1344A METHOD 1005.1) (TEST CONDITION 4) (TEST TIME CONDITON A)	Appearance: No Damage Contact Resistance: 10 milliohm Maximum
Solderability	Solder Time: 3 +/- 0.5 seconds Solder Temperature: 230 +/- 5 C	95% of immersed area must show no voids, pin holes, etc.
Resistance to Solder Heats	Solder Time: 3 +/- 0.5 seconds Solder Temperature: 260 +/- 5 C	Appearance: No Damage

DRWG. NO.
PSX-42002-0001

DRWG. NO.
PSX-42002-0001

REV.					
SHT.					
FILE NAME PS42002X4	= =	REVISE ONLY ON CAD SYSTEM	REV.	2	
DGN	THIS DRAWING CONTAINS INFORMATION THAT IS PROPRIETARY TO MOLEX INC. AND SHOULD NOT BE USED WITHOUT WRITTEN PERMISSION.		SHT.	4	



MOLEX INCORPORATED

LISLE, ILL.

60532

U.S.A.

PRODUCT SPECIFICATION
 FOR .084/(2.13) DIAMETER SERIES
 PIN AND SOCKET HEADER ASSEMBLIES

(HOT TIN PLATED TERMINALS ONLY)

LTR.	REVISIONS
1	"X" RELEASE PER ECN# UI0688 91/02/21 KBP
2	REVISED PER ECN# UI0721 91/04/03 KBP

DRWG. NO. PSX-42002-0001

REV.
SHT.

FILE NAME PS42002X5	DGN
------------------------	-----



REVISE ONLY ON CAD SYSTEM

REV.	2
SHT.	5

THIS DRAWING CONTAINS INFORMATION THAT IS PROPRIETARY TO MOLEX INC. AND SHOULD NOT BE USED WITHOUT WRITTEN PERMISSION.

DRWG. NO. PSX-42002-0001

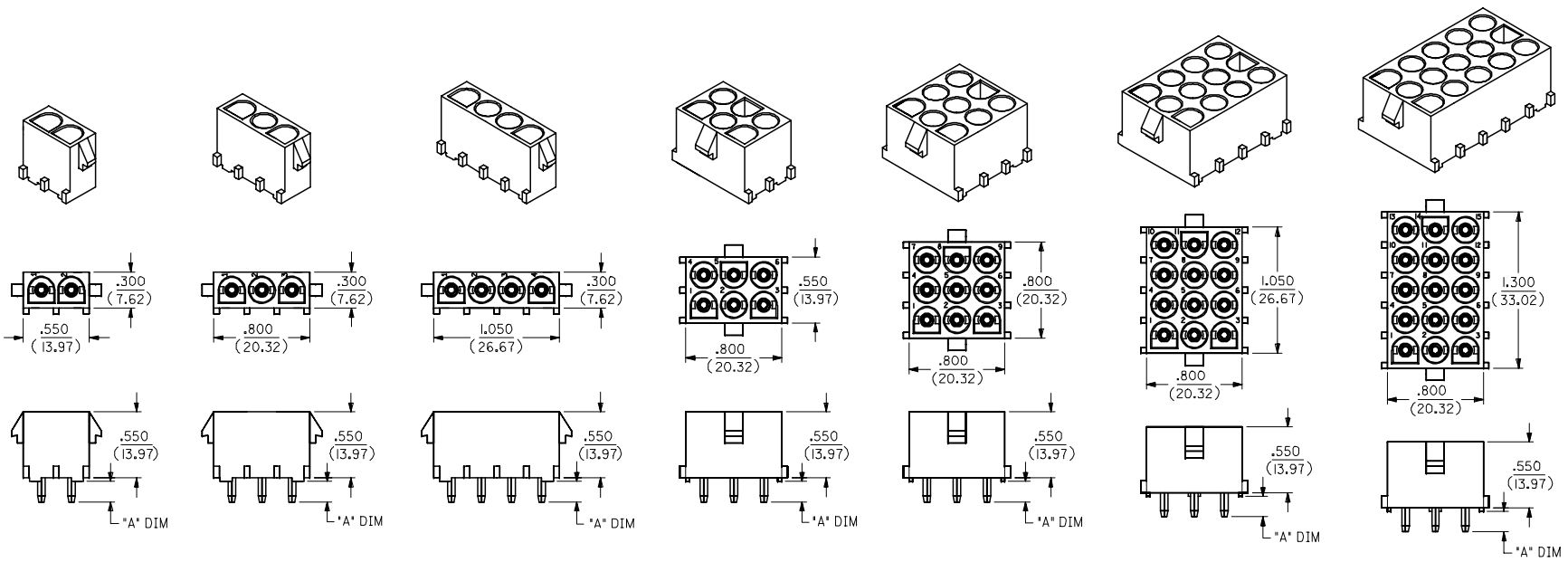

SEE CHARTS FOR "A" DIMENSION

P.C. BOARD MOUNTING DIMENSIONS

2, 3, & 4 POSITION HEADER ASSEMBLIES

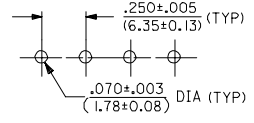

6, 9, 12 & 15 POSITION HEADER ASSEMBLIES

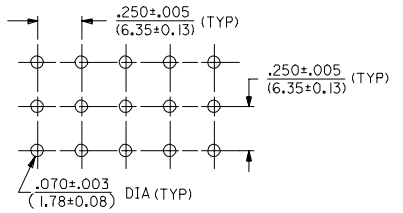

NOTES:

- 1) MATERIAL CODES:
 "A"= NYLON 6/6, 94V-2, NATURAL
 "B"= POLYESTER, 94V-0, BRICK RED
 "C"= PLOYESTER, 94V-0, WHITE/NATURAL
- 2) PLATING CODES:
 A = TIN 140m.I (3.50 MICRONS) TO 240m.I (6.00 MICRONS).
 "B" = 30 m.I./(.076 MICRONS) MINIMUM SELECT GOLD, AND
 100 m.I./(.254 MICRONS) MINIMUM SELECT TIN.
 50 m.I./(.127 MICRONS) MINIMUM NICKEL OVERALL.
- 3) TERMINAL LENGTH CODES:
 1= TERMINAL FOR .062/(1.57) THICK PC BOARD
 2= TERMINAL FOR .125/(3.18) THICK PC BOARD
- 4) DIMENSIONS ARE FOR REFERENCE ONLY UNLESS INDICATED OTHERWISE.
- 5) HEADER ASSEMBLY HOUSINGS MATE WITH :
 - PLUG HOUSINGS, .084/(2.13) DIA. SERIES: (42021-**)
- 6) CONTACTS ARE ON .250/(6.35) GRID CENTERLINE SPACING.

LEGEND:

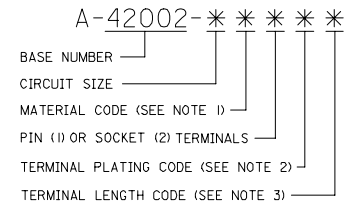

ENTER DESCRIPTION EC NO: 12005-0180 DRWNS: SSUDHIR 2006/01/20 CHKDG: JLOWE 2006/01/20 APPR: KPRASAD 2006/01/23 REV DESCRIPTION	QUALITY SYMBOLS	GENERAL TOLERANCES (UNLESS SPECIFIED)	DIMENSION STYLE	SCALE	DESIGN UNITS	THIRD ANGLE PROJECTION	
	$\nabla=0$ $\nabla=0$	mm INCH 4 PLACES ± --- ± --- 3 PLACES ± --- ± --- 2 PLACES ± --- ± --- 1 PLACE ± --- ± --- ANGULAR ± ---°	IN/MM	---	INCH		
			DRAWN BY SSUDHIR DATE 2004/06/08	TITLE	HEADER HOUSING ASSEMBLY .084/(2.13) DIA. SERIES		
			CHECKED BY GJLOWE DATE 2004/06/08	APPROVED BY GJLOWE DATE 2004/06/08	MOLEX INCORPORATED		
		DRAFT WHERE APPLICABLE MUST REMAIN WITHIN DIMENSIONS	MATERIAL NO. SEE CHART	DOCUMENT NO. SDA-42002-*****	SHEET NO. 1 OF 5		
			SIZE A2	THIS DRAWING CONTAINS INFORMATION THAT IS PROPRIETARY TO MOLEX INCORPORATED AND SHOULD NOT BE USED WITHOUT WRITTEN PERMISSION			

PART NO.	ENG. NO.	CIRCUIT SIZE	HOUSING MATERIAL (SEE NOTE 1)	PIN (1) OR SOCKET (2) TERMINALS	TERMINAL PLATING (SEE NOTE 2)	TERMINAL LENGTH (SEE NOTE 3)	*A* DIM ±.015
IO-84-4I20	A-42002-12A1A1	12	A	1	A	1	.17/(4,3)
IO-84-4I21	A-42002-12B1A1		B	1	A	1	
IO-84-5I20	A-42002-12C1A1		C	1	A	1	
IO-84-4I22	A-42002-12A2A1		A	2	A	1	
IO-84-4I23	A-42002-12B2A1		B	2	A	1	
IO-84-5I21	A-42002-12C2A1		C	2	A	1	
PRELIMINARY	A-42002-12A1A2		A	1	A	2	.23/(5,8)
PRELIMINARY	A-42002-12B1A2		B	1	A	2	
PRELIMINARY	A-42002-12C1A2		C	1	A	2	
PRELIMINARY	A-42002-12A2A2		A	2	A	2	
PRELIMINARY	A-42002-12B2A2		B	2	A	2	
PRELIMINARY	A-42002-12C2A2		C	2	A	2	
IO-84-4I50	A-42002-15A1A1	15	A	1	A	1	.17/(4,3)
IO-84-4I51	A-42002-15B1A1		B	1	A	1	
IO-84-5I50	A-42002-15C1A1		C	1	A	1	
IO-84-4I52	A-42002-15A2A1		A	2	A	1	
IO-84-4I53	A-42002-15B2A1		B	2	A	1	
IO-84-5I51	A-42002-15C2A1		C	2	A	1	
PRELIMINARY	A-42002-15A1A2		A	1	A	2	.23/(5,8)
PRELIMINARY	A-42002-15B1A2		B	1	A	2	
PRELIMINARY	A-42002-15C1A2		C	1	A	2	
PRELIMINARY	A-42002-15A2A2		A	2	A	2	
PRELIMINARY	A-42002-15B2A2		B	2	A	2	
PRELIMINARY	A-42002-15C2A2		C	2	A	2	

LEGEND:

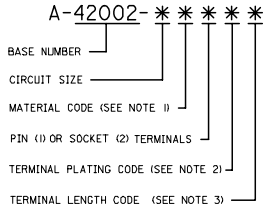

EC NO. 12005-0180 DRAWINGSDHIR 2006/01/20 CHKDCSDHIR 2006/01/20 APPROVEDASD 2006/01/23 D	QUALITY SYMBOLS 	GENERAL TOLERANCES (UNLESS SPECIFIED) mm INCH 4 PLACES ± --- ± --- 3 PLACES ± --- ± --- 2 PLACES ± --- ± --- 1 PLACE ± --- ± --- ANGULAR ±1/2°		DIMENSION STYLE IN/MM	SCALE 1:1	DESIGN UNITS INCH	THIRD ANGLE PROJECTION
		DRAWN BY SSUDHIR 2004/06/08	DATE 2004/06/08	TITLE HEADER HOUSING ASSEMBLES .084/(2.13) DIA. SERIES			
		CHECKED BY GJLOWE 2004/06/08	DATE 2004/06/08	APPROVED BY GJLOWE 2004/06/08			
		MATERIAL NO. SEE CHART		DOCUMENT NO. SDA-42002-*****		SHEET NO. 3 OF 3	

DRAFT WHERE APPLICABLE MUST REMAIN WITHIN DIMENSIONS
 THIS DRAWING CONTAINS INFORMATION THAT IS PROPRIETARY TO MOLEX INCORPORATED AND SHOULD NOT BE USED WITHOUT WRITTEN PERMISSION

PART NO.	ENG. NO.	CIRCUIT SIZE	HOUSING MATERIAL (SEE NOTE 1)	PIN (1) OR SOCKET (2) TERMINALS	TERMINAL PLATING (SEE NOTE 2)	TERMINAL LENGTH (SEE NOTE 3)	"A" DIM ±.015
IO-84-4024	A-42002-2A1B1	2	A	1	B	1	.17/(4,3)
IO-84-4025	A-42002-2B1B1		B	1	B	1	
IO-84-5022	A-42002-2C1B1		C	1	B	1	
IO-84-4026	A-42002-2A2B1		A	2	B	1	
IO-84-4027	A-42002-2B2B1		B	2	B	1	
IO-84-5023	A-42002-2C2B1		C	2	B	1	
PRELIMINARY	A-42002-2A1B2		A	1	B	2	.23/(5,8)
PRELIMINARY	A-42002-2B1B2		B	1	B	2	
PRELIMINARY	A-42002-2C1B2		C	1	B	2	
PRELIMINARY	A-42002-2A2B2		A	2	B	2	
PRELIMINARY	A-42002-2B2B2	B	2	B	2		
PRELIMINARY	A-42002-2C2B2	C	2	B	2		
IO-84-4034	A-42002-3A1B1	3	A	1	B	1	.17/(4,3)
IO-84-4035	A-42002-3B1B1		B	1	B	1	
IO-84-5032	A-42002-3C1B1		C	1	B	1	
IO-84-4036	A-42002-3A2B1		A	2	B	1	
IO-84-4037	A-42002-3B2B1		B	2	B	1	
IO-84-5033	A-42002-3C2B1		C	2	B	1	
PRELIMINARY	A-42002-3A1B2		A	1	B	2	.23/(5,8)
PRELIMINARY	A-42002-3B1B2		B	1	B	2	
PRELIMINARY	A-42002-3C1B2		C	1	B	2	
PRELIMINARY	A-42002-3A2B2		A	2	B	2	
PRELIMINARY	A-42002-3B2B2	B	2	B	2		
PRELIMINARY	A-42002-3C2B2	C	2	B	2		
IO-84-4044	A-42002-4A1B1	4	A	1	B	1	.17/(4,3)
IO-84-4045	A-42002-4B1B1		B	1	B	1	
IO-84-5042	A-42002-4C1B1		C	1	B	1	
IO-84-4046	A-42002-4A2B1		A	2	B	1	
IO-84-4047	A-42002-4B2B1		B	2	B	1	
IO-84-5043	A-42002-4C2B1		C	2	B	1	
PRELIMINARY	A-42002-4A1B2		A	1	B	2	.23/(5,8)
PRELIMINARY	A-42002-4B1B2		B	1	B	2	
PRELIMINARY	A-42002-4C1B2		C	1	B	2	
PRELIMINARY	A-42002-4A2B2		A	2	B	2	
PRELIMINARY	A-42002-4B2B2	B	2	B	2		
PRELIMINARY	A-42002-4C2B2	C	2	B	2		
IO-84-4064	A-42002-6A1B1	6	A	1	B	1	.17/(4,3)
IO-84-4065	A-42002-6B1B1		B	1	B	1	
IO-84-5062	A-42002-6C1B1		C	1	B	1	
IO-84-4066	A-42002-6A2B1		A	2	B	1	
IO-84-4067	A-42002-6B2B1		B	2	B	1	
IO-84-5063	A-42002-6C2B1		C	2	B	1	
PRELIMINARY	A-42002-6A1B2		A	1	B	2	.23/(5,8)
PRELIMINARY	A-42002-6B1B2		B	1	B	2	
PRELIMINARY	A-42002-6C1B2		C	1	B	2	
PRELIMINARY	A-42002-6A2B2		A	2	B	2	
PRELIMINARY	A-42002-6B2B2	B	2	B	2		
PRELIMINARY	A-42002-6C2B2	C	2	B	2		
IO-84-4094	A-42002-9A1B1	9	A	1	B	1	.17/(4,3)
IO-84-4095	A-42002-9B1B1		B	1	B	1	
IO-84-5092	A-42002-9C1B1		C	1	B	1	
IO-84-4096	A-42002-9A2B1		A	2	B	1	
IO-84-4097	A-42002-9B2B1		B	2	B	1	
IO-84-5093	A-42002-9C2B1		C	2	B	1	
PRELIMINARY	A-42002-9A1B2		A	1	B	2	.23/(5,8)
PRELIMINARY	A-42002-9B1B2		B	1	B	2	
PRELIMINARY	A-42002-9C1B2		C	1	B	2	
PRELIMINARY	A-42002-9A2B2		A	2	B	2	
PRELIMINARY	A-42002-9B2B2	B	2	B	2		
PRELIMINARY	A-42002-9C2B2	C	2	B	2		

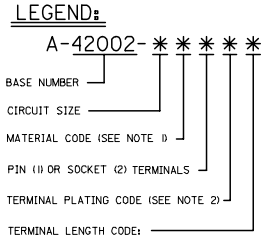

EC NO. 12005-0180 DRAWN BY: SSUDHIR 2006/01/20 CHECKED BY: CHIKOSUDHIR 2006/01/20 APPROVED BY: (APPROPRIATE)	QUALITY SYMBOLS ▽=0 ▽=0	GENERAL TOLERANCES (UNLESS SPECIFIED) .mm INCH		DIMENSION STYLE IN/MM		SCALE: 1:1	DESIGN UNITS: INCH	THIRD ANGLE PROJECTION
		4 PLACES ± --- ± --- 3 PLACES ± --- ± --- 2 PLACES ± --- ± --- 1 PLACE ± --- ± ---	DRAWN BY: SSUDHIR 2004/06/08 CHECKED BY: GJLOWE 2004/06/08 APPROVED BY: GJLOWE 2004/06/08	TITLE: ASSEMBLY, PIN AND SOCKET HEADERS .084/(2.13) DIA. SERIES			MATERIAL NO. SDA-42002-***** DOCUMENT NO.	SHEET NO. 4 OF 5
DRAFT WHERE APPLICABLE MUST REMAIN WITHIN DIMENSIONS		SEE CHART		THIS DRAWING CONTAINS INFORMATION THAT IS PROPRIETARY TO MOLEX INCORPORATED AND SHOULD NOT BE USED WITHOUT WRITTEN PERMISSION				

20	19	18	17	16	15	14	13	12	11	10	9	8	7	6	5	4	3	2	1
PART NO.	ENG. NO.	CIRCUIT SIZE	HOUSING MATERIAL (SEE NOTE 1)	PIN (1) OR SOCKET (2) TERMINALS	TERMINAL PLATING (SEE NOTE 2)	TERMINAL LENGTH (SEE NOTE 3)	'A' DIM ±.015												
IO-84-4I24	A-42002-12A1B1	12	A	1	B	1	.17/(4,3)												
IO-84-4I25	A-42002-12B1B1		B	1	B	1													
IO-84-5I22	A-42002-12C1B1		C	1	B	1													
IO-84-4I26	A-42002-12A2B1		A	2	B	1													
IO-84-4I27	A-42002-12B2B1		B	2	B	1													
IO-84-5I23	A-42002-12C2B1		C	2	B	1													
PRELIMINARY	A-42002-12A1B2		A	1	B	2	.23/(5,8)												
PRELIMINARY	A-42002-12B1B2		B	1	B	2													
PRELIMINARY	A-42002-12C1B2		C	1	B	2													
PRELIMINARY	A-42002-12A2B2	A	2	B	2														
PRELIMINARY	A-42002-12B2B2	B	2	B	2														
PRELIMINARY	A-42002-12C2B2	C	2	B	2														
IO-84-4I54	A-42002-15A1B1	15	A	1	B	1	.17/(4,3)												
IO-84-4I55	A-42002-15B1B1		B	1	B	1													
IO-84-5I52	A-42002-15C1B1		C	1	B	1													
IO-84-4I56	A-42002-15A2B1		A	2	B	1													
IO-84-4I57	A-42002-15B2B1		B	2	B	1													
IO-84-5I53	A-42002-15C2B1		C	2	B	1													
PRELIMINARY	A-42002-15A1B2		A	1	B	2	.23/(5,8)												
PRELIMINARY	A-42002-15B1B2		B	1	B	2													
PRELIMINARY	A-42002-15C1B2		C	1	B	2													
PRELIMINARY	A-42002-15A2B2	A	2	B	2														
PRELIMINARY	A-42002-15B2B2	B	2	B	2														
PRELIMINARY	A-42002-15C2B2	C	2	B	2														

LEGEND:

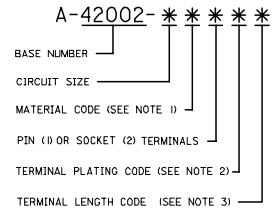

EC NO. 12005-0180 DRAWNSUDHIR 2006/01/20 CHECKSUDHIR 2006/01/20 APPROVEDSUDHIR 2006/01/20	QUALITY SYMBOLS 	GENERAL TOLERANCES (UNLESS SPECIFIED)		DIMENSION STYLE	SCALE	DESIGN UNITS	THIRD ANGLE PROJECTION
		mm	INCH	IN/MM	1:1	INCH	
DRAFT WHERE APPLICABLE MUST REMAIN WITHIN DIMENSIONS	SIZE A 1	4 PLACES ±	±	DRAWN BY	DATE	TITLE	ASSEMBLY, PIN AND SOCKET HEADERS .084/(2.13) DIA. SERIES MOLEX INCORPORATED
		3 PLACES ±	±	SSUDHIR	2004/06/08	SDA-42002-***** SHEET NO. 5 OF 5	
		2 PLACES ±	±	CHECKED BY	DATE		
		1 PLACE ±	±	GJLOWE	2004/06/08		
ANGULAR ±1/2°		APPROVED BY	DATE				
				GJLOWE	2004/06/08		