

13 12 11 10 9 8 7 6 5 4 3 2 1

# OPTION G

- NOTES:  
 1. MATERIAL:  
 HOUSING: POLYESTER/IBT, GLASS FILLED, UL94 V-0,  
 COLOR: BLACK  
 TERMINAL: PHOSPHOR BRONZE  
 2. FINISH:  
 15 GOLD: 0.38 MICROMETERS/15 MICROINCHES MINIMUM GOLD IN  
 1.91 MICROMETERS/75 MICROINCHES MINIMUM TIN  
 OVER NICKEL UNDERPLATE OVERALL  
 3. TO BE USED WITH 22 AWG STRANDED WIRE WITH (1.35)/.053  
 DIAMETER MAXIMUM INSULATION  
 4. SEE TABLE FOR AVAILABLE CIRCUIT SIZES  
 5. STANDARD PACKAGING PER PK-70873-0001. OPTIONAL PACKAGING  
 MAY BE AVAILABLE. REQUEST DRAWING PK-70400  
 6. PARTS STACKABLE END TO END ON (2.54)/.100 CENTERS  
 7. PRODUCT SPECIFICATION: PS-70400  
 8. SEE DRAWING SDA-70400-\*\*\*\* (SHEET 3) FOR OPTIONAL  
 HOUSING DETAILS  
 9. 4 CIRCUIT SHOWN, 3-25 CIRCUITS HAVE 2 RIBS  
 10. TO MATE WITH MOLEX PART NUMBERS: A-70373-\*\*\*\*,  
 A-70375-\*\*\*\*, A-70389-\*\*\*\*, A-70391-\*\*\*\*,  
 A-70107-\*\*\*\*, A-70018-\*\*\*\*, A-70543-\*\*\*\*,  
 A-70553-\*\*\*\*, A-70541-\*\*\*\*, A-70551-\*\*\*\*,  
 A-70545-\*\*\*\*, A-70555-\*\*\*\*  
 11. 2 CIRCUIT ASSEMBLIES SUPPLIED AS GROUPED PAIRS

CKT. SIZE	A	B	EDP. NO.
2	( 2.54 ) .100	( 5.05 ) .199	I4-56-7027
3	( 5.08 ) .200	( 7.59 ) .299	I4-56-7037
4	( 7.62 ) .300	( 10.13 ) .399	I4-56-7047
5	( 10.16 ) .400	( 12.67 ) .499	I4-56-7057
6	( 12.70 ) .500	( 15.21 ) .599	I4-56-7067
7	( 15.24 ) .600	( 17.75 ) .699	I4-56-7077
8	( 17.78 ) .700	( 20.29 ) .799	I4-56-7087
9	( 20.32 ) .800	( 22.83 ) .899	I4-56-7097
10	( 22.86 ) .900	( 25.37 ) .999	I4-56-7107
11	( 25.40 ) 1.000	( 27.91 ) 1.099	I4-56-7117
12	( 27.94 ) 1.100	( 30.45 ) 1.199	I4-56-7127
13	( 30.48 ) 1.200	( 32.99 ) 1.299	I4-56-7137
14	( 33.02 ) 1.300	( 35.53 ) 1.399	I4-56-7147
15	( 35.56 ) 1.400	( 38.07 ) 1.499	I4-56-7157
16	( 38.10 ) 1.500	( 40.61 ) 1.599	I4-56-7167
17	( 40.64 ) 1.600	( 43.15 ) 1.699	I4-56-7177
18	( 43.18 ) 1.700	( 45.69 ) 1.799	I4-56-7187
19	( 45.72 ) 1.800	( 48.23 ) 1.899	I4-56-7197
20	( 48.26 ) 1.900	( 50.77 ) 1.999	I4-56-7207
21	( 50.80 ) 2.000	( 53.31 ) 2.099	I4-56-7217
22	( 53.34 ) 2.100	( 55.85 ) 2.199	I4-56-7227
23	( 55.88 ) 2.200	( 58.39 ) 2.299	I4-56-7237
24	( 58.42 ) 2.300	( 60.93 ) 2.399	I4-56-7247
25	( 60.96 ) 2.400	( 63.47 ) 2.499	I4-56-7257

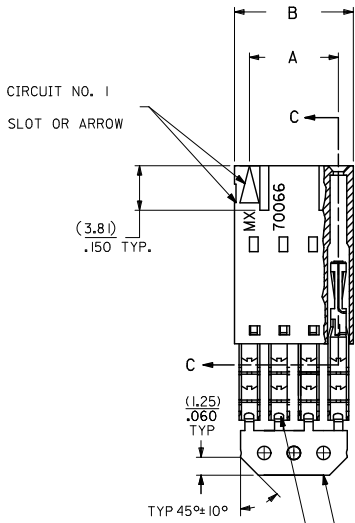
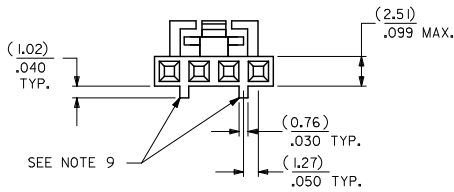

## SECTION C-C

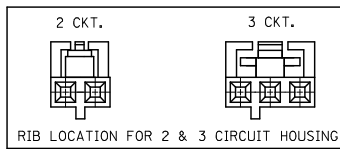
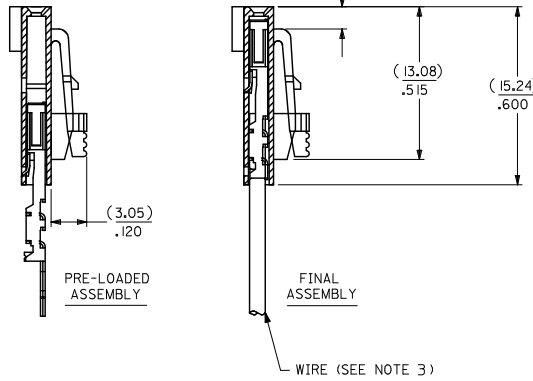

I.D. SLOT CODE TO WIRE GAUGE CHART	
I.D. SLOT CODE	WIRE GAUGE
D	22 AWG.

PLATING CODE (STRIPE ON CARRIER STRIP)	
PLATING	COLOR
15 GOLD	YELLOW

REMOVE ENG. NO. E.C. NO. UGP2011-110	QUALITY SYMBOLS	GENERAL TOLERANCES (UNLESS SPECIFIED)		DIMENSION STYLE	SCALE	DESIGN UNITS	THIRD ANGLE PROJECTION
		mm	INCH	MM/IN	INCH	INCH	INCH
2010/10/19	MSI BARRA	4 PLACES ± .010	± .010	DRAWN BY	DATE	TITLE	
2010/10/19	CHANDRAN	3 PLACES ± .010	± .010	CHECKED BY	DATE	ASSEMBLY, SL CONNECTOR	
2010/11/24	APPR: SMILLER	2 PLACES ± .025	± .014	WAZ	1987/10/26	SINGLE ROW	
		1 PLACE ± 0.35	± .010	APPROVED BY	DATE	2.54/.100	
		ANGULAR ± 1/2°		SMILLER	2010/11/24	MOLEX INCORPORATED	
		DRAFT WHERE APPLICABLE MUST REMAIN WITHIN DIMENSIONS		MATERIAL NO.	DOCUMENT NO.	SHEET NO.	
				SEE TABLE	SDA-70400-2976-2999	1 OF 1	

12 11 10 9 8 7 6 5 4 3 2 1