

Distributed by:

JAMECO[®]
ELECTRONICS

www.Jameco.com ♦ 1-800-831-4242

The content and copyrights of the attached
material are the property of its owner.

Jameco Part Number 741407

FEATURES AND SPECIFICATIONS

Features and Benefits

- Positive housing locks to mate with Mini-Fit, Jr. receptacles
- Fully isolated terminals to protect contacts from damage
- Mini-Fit, BMI connectors have the capability of being selectively loaded with longer pins for grounding
- 43759 is a first-mate/last-break header

Reference Information

Product Specification: PS-5556-0002
 Packaging: Tray and bag
 UL File No.: E29179
 CSA File No.: LR19980
 TUV License No.: R75142
 Mates With: [42385](#), [42474](#), [44475](#) and [5557](#)
 dual row receptacles
 Use With: Standard Mini-Fit terminals
 Designed In: Millimeters

Electrical

Voltage: 600V
 Current: (Used with 16 AWG)

Circuits	2-3	4-6	7-10	12-24
Amperes-BMI	9	8	7	6
Amperes-BMI with HCS	12	11	10	9

Contact Resistance: 10mΩ max.
 Dielectric Withstanding Voltage: 1500V
 Insulation Resistance: 1000 MΩ min.

Mechanical

Insertion Force to PCB: 5.0kg max.
 Mating Force: 0.7kg (1.54 lb) max.
 Unmating Force: 0.35kg (0.7 lb) min.
 Normal Force: 200g min.
 Durability: 30 cycles

Physical

Housing: 6/6 nylon, UL 94V-2 or 94V-0
 Contact: Brass
 Plating: Tin, select Gold or overall Gold
 Operating Temperature: -40 to +105°C



4.20mm (.165") Pitch Mini-Fit, BMI™ Header

42404/43759

Right Angle Dual Row

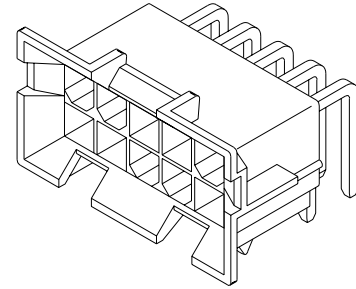

CATALOG DRAWING (FOR REFERENCE ONLY)

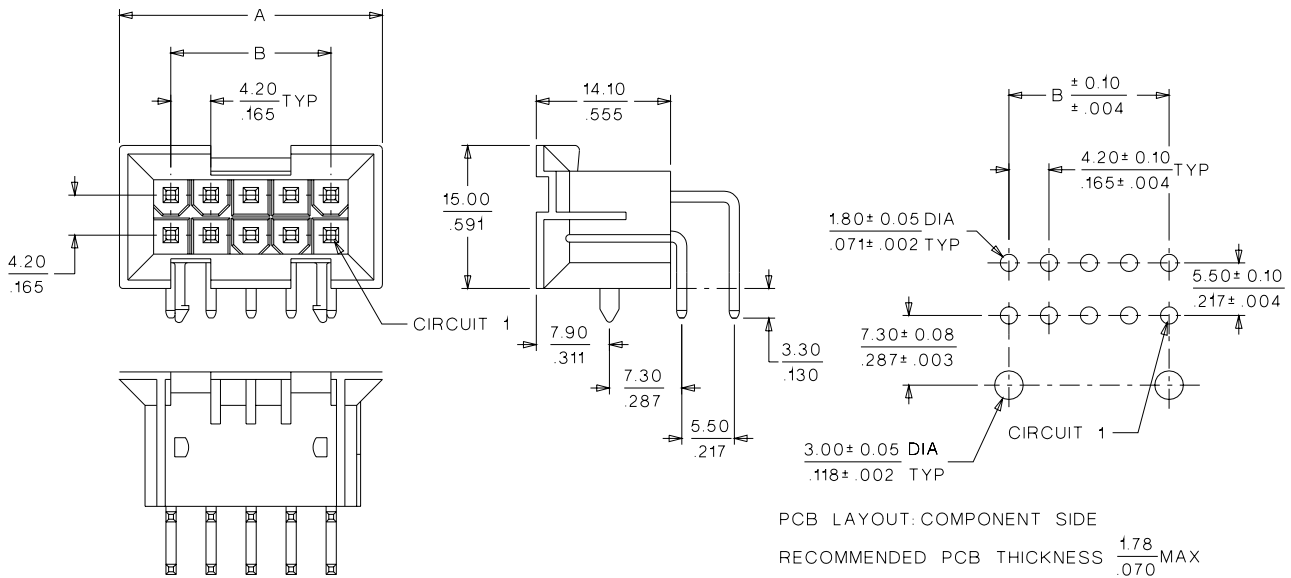

ORDERING INFORMATION AND DIMENSIONS

Circuits	Order No.				Dimension	
	Tin Plated		Gold Plated		A	B
	94V-2	94V-0	94V-2	94V-0		
4	• 15-24-6040	• 15-24-9044	• 15-24-9043	• 15-24-9045	15.00 (.590)	4.20 (.165)
6	• 15-24-6060	• 15-24-9064	• 15-24-9063	• 15-24-9065	19.20 (.760)	8.40 (.331)
10	• 15-24-6100	• 15-24-9104	• 15-24-9103	• 15-24-9105	27.60 (1.090)	16.80 (.661)
14	• 15-24-6140	• 15-24-9144	• 15-24-9143	• 15-24-9145	36.00 (1.420)	25.20 (.992)
16		• 15-24-9164		• 15-24-9165	40.20 (1.580)	29.40 (1.157)
18	• 15-24-6180	• 15-24-9184	• 15-24-9183	• 15-24-9185	44.40 (1.750)	33.60 (1.323)
24	• 15-24-6240	• 15-24-9244	• 15-24-9243	• 15-24-9245	57.00 (2.240)	46.20 (1.819)
36	• 43759-0001				82.20 (3.240)	71.40 (2.811)

• US Standard Product, available through Molex franchised distributors



PRODUCT SPECIFICATION

MINI-FIT BMI

1.0 SCOPE

This Product Specification covers performance requirements for the MINI-FIT BMI 4.20 mm (.165 inch) centerline (pitch) printed circuit board (PCB) connector series with Tin or Gold plating, and The MINI-FIT BMI connector series terminated with 16 to 28 AWG wire using Crimp technology with Tin or Gold plating.

2.0 PRODUCT DESCRIPTION

2.1 PRODUCT NAME AND SERIES NUMBER (S)

<u>PRODUCT NAME</u>	<u>PART NUMBER</u>
Female Crimp Terminal	5556-****
Male Crimp Terminal	5558-****
Receptacle Housing	42474-****
Plug Housing	42475-****
Vertical Header Assembly	42440-****
Right Angle Header Assembly	42404-****
Receptacle Header Assembly	42385-****
Plug Housing	43588-06*1
Right Angle Header Assembly	44499-****

2.2 DIMENSIONS, MATERIALS, PLATINGS AND MARKINGS

See the appropriate sales drawings for the information on dimensions, materials, platings and markings.

2.3 SAFETY AGENCY APPROVALS

UL File: E29179
CSA Certificate: LR 19980
TUV Certificate: R75142-8

3.0 APPLICABLE DOCUMENTS AND SPECIFICATIONS

See sales drawings and the other sections of this specification for the necessary referenced documents and specifications

4.0 RATINGS

4.1 VOLTAGE

600 Volts AC (RMS) (or 600 Volts DC)

4.2 CURRENT AND APPLICABLE WIRES

Maximum Insulation Diameter and Applicable Wire Gauges	16 AWG: 3.10/. 122 MAXIMUM
	18-24 AWG: 3.10/. 122 MAXIMUM
	22-28 AWG: 1.80/. 071 MAXIMUM

REVISION: D3	EGR/ECN INFORMATION: EC No: UCP2005-1352 DATE: 2005 / 01 / 05	TITLE: PRODUCT SPECIFICATION FOR MINI-FIT BMI CONNECTOR SYSTEM	SHEET No. 1 of 5
DOCUMENT NUMBER: PS-5556-002	CREATED / REVISED BY: BANDURA	CHECKED BY: BANDURA	APPROVED BY: MARGULIS



PRODUCT SPECIFICATION

4.2 CURRENT AND APPLICABLE WIRES (continued)

MAXIMUM CURRENT RATING (Amperes)										
Brass					Phosphor Bronze					
Wire \ Ckt. Size	2 & 3	4 - 6	7 - 10	12 - 24	Wire \ Ckt. Size	2 & 3	4 - 6	7 - 10	12 - 24	
AWG #16	9	8	7	6	AWG #16	8	7	6	5	
AWG #18	9	8	7	6	AWG #18	8	7	6	5	
AWG #20	7	6	5	5	AWG #20	6	5	4	4	
AWG #22	5	4	4	4	AWG #22	4	3	3	3	
AWG #24	4	3	3	3	AWG #24	3	2	2	2	
AWG #26	3	2	2	2	AWG #26	2	1	1	1	
AWG #28	2	1	1	1	AWG #28	1	1	1	1	

4.3 TEMPERATURE

Operating: * - 40°C to + 105°C

Nonoperating: - 40°C to + 105°C

**Including 30°C terminal temperature at rated current*

5.0 PERFORMANCE

5.1 ELECTRICAL REQUIREMENTS

ITEM	DESCRIPTION	TEST CONDITION	REQUIREMENT
1	Contact Resistance (Low Level)	Mate connectors: apply a maximum voltage of 20 mV and a current of 100 mA. Wire resistance shall be removed from the measured value.	10 milliohms MAXIMUM [initial]
2	Contact Resistance @ Rated Current	Mate connectors: apply a maximum voltage of 20 mV at rated current.	10 milliohms MAXIMUM [initial]
3	Contact Resistance of Wire Termination (Low Level)	Terminate the applicable wire to the terminal and measure wire using a voltage of 20 mV and a current of 100 mA.	5 milliohms MAXIMUM [initial]

REVISION: D3	EGR/ECN INFORMATION: EC No: UCP2005-1352 DATE: 2005 / 01 / 05	TITLE: PRODUCT SPECIFICATION FOR MINI-FIT BMI CONNECTOR SYSTEM	SHEET No. 2 of 5
DOCUMENT NUMBER: PS-5556-002	CREATED / REVISED BY: BANDURA	CHECKED BY: BANDURA	APPROVED BY: MARGULIS



PRODUCT SPECIFICATION

4	Insulation Resistance	Mate connectors: apply a voltage of 500 VDC between adjacent terminals and between terminals to ground.	1000 Megohms MINIMUM
----------	------------------------------	---	-------------------------

5.1 ELECTRICAL REQUIREMENTS (continued)

ITEM	DESCRIPTION	TEST CONDITION	REQUIREMENT
5	Dielectric Withstanding Voltage	Mate connectors: apply a voltage of 1500 VAC for 1 minute between adjacent terminals and between terminals to ground.	No breakdown. Current leakage < 5 mA
6	Temperature Rise (via Current Cycling)	Mate connectors. Measure the temperature rise at the rated current after 96 hours, during current cycling (45 minutes ON and 15 minutes OFF per hour) for 240 hours, and after final 96-hour steady state.	Temperature rise: +30°C MAXIMUM

5.2 MECHANICAL REQUIREMENTS

ITEM	DESCRIPTION	TEST CONDITION	REQUIREMENT
1	Terminal Mate and Unmate Forces	Insert and withdraw terminal (male to female) at a rate of 25 ± 6 mm (1 ± ¼ inch) per minute.	14.7 N (3.30 lbf) MAXIMUM insertion force & 1.0 N (0.02 lbf) MINIMUM withdrawal force
2	Crimp Terminal Retention Force (in Housing)	Axial pullout force on the terminal in the housing at a rate of 25 ± 6 mm (1 ± ¼ inch) per minute.	30 N (6.74 lbf) MINIMUM retention force
3	Terminal Pin to Header Retention Force	Axial pullout force on the terminal in the housing at a rate of 25 ± 6 mm (1 ± ¼ inch) per minute.	4.45 N (1.00 lbf) MINIMUM retention force
4	Durability	Mate connectors up to 30 cycles at a maximum rate of 10 cycles per minute prior to Environmental Tests.	20 milliohms MAXIMUM
5	Vibration (Random)	Mate connectors and vibrate per EIA 364-28, test condition VII.	10 milliohms MAXIMUM (change from initial) & Discontinuity < 1 microsecond
6	Shock (Mechanical)	Mate connectors and shock at 50 g's with ½ sine wave (11 milliseconds) shocks in the ±X, ±Y, ±Z axes, (18 shocks total).	20 milliohms MAXIMUM & Discontinuity < 1 microsecond

REVISION: D3	EGR/ECN INFORMATION: EC No: UCP2005-1352 DATE: 2005 / 01 / 05	TITLE: PRODUCT SPECIFICATION FOR MINI-FIT BMI CONNECTOR SYSTEM	SHEET No. 3 of 5
DOCUMENT NUMBER: PS-5556-002	CREATED / REVISED BY: BANDURA	CHECKED BY: BANDURA	APPROVED BY: MARGULIS



PRODUCT SPECIFICATION

5.2 MECHANICAL REQUIREMENTS (continued)

7	Wire Pullout Force (Axial)	Apply an axial pullout force on the wire at a rate of 25 ± 6 mm (1 ± ¼ inch).	16 Awg = 88.0 N (19.8 lbf) Min. 18 Awg = 88.0 N (19.8 lbf) Min. 20 Awg = 59.0 N (13.3 lbf) Min. 22 Awg = 39.0 N (8.78 lbf) Min. 24 Awg = 29.0 N (6.52 lbf) Min. 26 Awg = 19.0 N (4.27 lbf) Min. 28 Awg = 9.80 N (2.20 lbf) Min.
8	Crimp Terminal Insertion Force (into Housing)	Apply an axial insertion force on the terminal at a rate of 25 ± 6 mm (1 ± ¼ inch).	15.0 N (3.37 lbf) MAXIMUM insertion force
9	Normal Force	Apply a perpendicular force.	0.49 N (50 grams) MINIMUM [Gold (noble) plating] OR 1.47 N (150 grams) MINIMUM [Tin (non-noble) plating]
10	PCB Engagement and Separation Forces	Engage and separate a connector at a rate of 25 ± 6 mm (1 ± ¼ inch) per minute. (Applies to parts with PCB retention features only)	49.0 N (11.0 lbf) MAXIMUM insertion force & 10.0 N (2.24 lbf) MINIMUM withdrawal force
11	Panel Insertion and Withdrawal Forces	Insert and withdraw a connector at a rate of 25 ± 6 mm (1 ± ¼ inch) per minute. (Applies to parts with panel retention features only)	225 N (50.7 lbf) MAXIMUM insertion force & 157 N (35.3 lbf) MINIMUM withdrawal force

5.3 ENVIRONMENTAL REQUIREMENTS

ITEM	DESCRIPTION	TEST CONDITION	REQUIREMENT
1	Thermal Shock	Mate connectors: expose for 5 cycles between temperatures -55 and 105°C; dwell 0.5 hours at each temperature.	20 milliohms MAXIMUM Visual: No Damage Dielectric Strength per 5.1.5 Insulation Resistance per 5.1.4
2	Thermal Aging	Mate connectors; expose to: 96 hours at 105 ± 2°C	20 milliohms MAXIMUM & Visual: No Damage

REVISION: D3	EGR/ECN INFORMATION: EC No: UCP2005-1352 DATE: 2005 / 01 / 05	TITLE: PRODUCT SPECIFICATION FOR MINI-FIT BMI CONNECTOR SYSTEM	SHEET No. 4 of 5
DOCUMENT NUMBER: PS-5556-002	CREATED / REVISED BY: BANDURA	CHECKED BY: BANDURA	APPROVED BY: MARGULIS



PRODUCT SPECIFICATION

3	Humidity (Steady State)	Mate connectors: expose to a temperature of $60 \pm 2^{\circ}\text{C}$ with a relative humidity of 90-95% for 96 hours.	20 milliohms MAXIMUM Dielectric Strength per 5.1.5 Insulation Resistance per 5.1.4 Visual: No Damage
----------	------------------------------------	---	---

5.3 ENVIRONMENTAL REQUIREMENTS (continued)

ITEM	DESCRIPTION	TEST CONDITION	REQUIREMENT
4	Solderability	Per SMES-152	Solder coverage: 95% MINIMUM (per SMES-152)
5	Solder Resistance	Dip connector terminal tails in solder: Solder Duration: 5 ± 0.5 seconds; Solder Temperature: $235 \pm 5^{\circ}\text{C}$	Visual: No Damage to insulator material
6	Cold Resistance	Mate connectors: Duration: 96 hours; Temperature: $-40 \pm 3^{\circ}\text{C}$	20 milliohms MAXIMUM Visual: No Damage
7	Corrosive Atmosphere: Sulfur Dioxide Gas (SO₂)	Mate connectors: Duration: 24 hours exposure. Atmosphere: 50 parts per million (ppm) SO ₂ Gas. Temperature: $40 \pm 3^{\circ}\text{C}$	20 milliohms MAXIMUM Visual: No damage

6.0 PACKAGING

Parts shall be packaged to protect against damage during handling, transit and storage.

REVISION: D3	EGR/ECN INFORMATION: EC No: UCP2005-1352 DATE: 2005 / 01 / 05	TITLE: PRODUCT SPECIFICATION FOR MINI-FIT BMI CONNECTOR SYSTEM	SHEET No. 5 of 5
DOCUMENT NUMBER: PS-5556-002		CREATED / REVISED BY: BANDURA	CHECKED BY: BANDURA
		APPROVED BY: MARGULIS	

CIRCUIT SIZE	DIM. 'A'	DIM. 'B'
6	.331 (8.40)	.76 (19.2)
8	.496 (12.60)	.92 (23.4)
10	.661 (16.80)	1.09 (27.6)
12	.827 (21.00)	1.25 (31.8)
14	.992 (25.20)	1.42 (36.0)
16	1.157 (29.40)	1.58 (40.2)
18	1.323 (33.60)	1.75 (44.4)
20	1.488 (37.80)	1.91 (48.6)
22	1.654 (42.00)	2.08 (52.8)
24	1.819 (46.20)	2.24 (57.0)

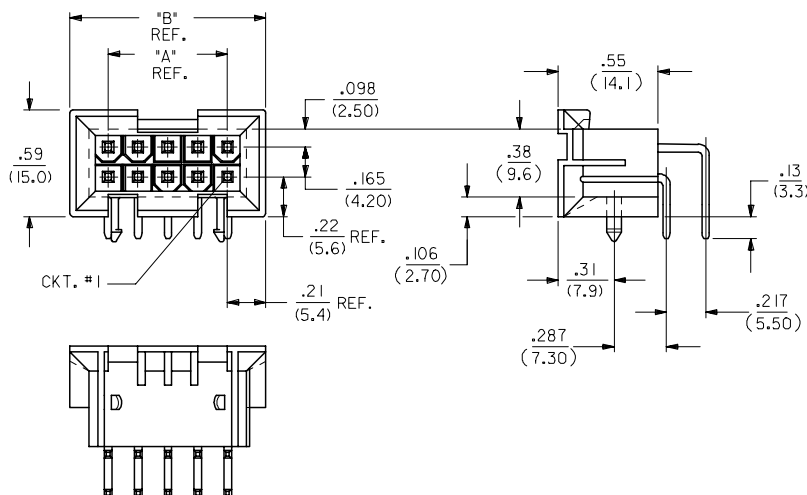

NOTES:

- HOUSING MATERIAL: "A" = NYLON 6/6, U.L. 94V-2, COLOR: NATURAL. "B" = NYLON 6/6, U.L. 94V-0, COLOR: NATURAL.
- TERMINAL MATERIAL: BRASS, ALLOY 260.
- 4-24 CKT. PARTS MATE WITH MINI-FIT JR. RECEPTACLES #5557, #42385 AND #42474. 2 CKT. PART MATES WITH #42385 AND #42474 ONLY.
- PART ALLOWS FOR UP TO .100/(2.54) MISALIGNMENT WITH MATING RECEPTACLE IN ANY DIRECTION. SEE MATING CONNECTOR DRAWINGS FOR SPECIFIC ALLOWANCES.
- TERMINAL PLATING:
 - .000100/(.00254) MIN. BRIGHT TIN OVER .000050/(.00127) MIN. NICKEL OVERALL.
 - .000030/(.00076) MIN. GOLD OVER .000050/(.00127) MIN. NICKEL OVERALL.
 - .000100/(.00254) MIN. MATTE TIN OVER .000050/(.00127) MIN. NICKEL OVERALL.
 - .000050/(.00127) MIN. GOLD OVER .000050/(.00127) MIN. NICKEL OVERALL.
 - .000030/(.00076) MIN. GOLD AND .000100/(.00254) MIN. MATTE TIN OVER .000050/(.00127) MIN. NICKEL OVERALL.
- THE PRIMARY SHIPPING CARTON WILL BE LABELED "COMPLIANT TO RoHS DIRECTIVE 2002/95/EC AND ELV ANNEX II OF DIRECTIVE 2000/53/EC." CARTONS WITHOUT THIS LABEL MAY CONTAIN PRODUCT WITH TIN-LEAD PLATING.
- PRODUCT SPECIFICATION AND PROCESSING PARAMETERS: SEE PS-5556-002
- CONNECTOR ASSEMBLIES ARE NOT TO BE MATED OR UNMATED WHILE CIRCUITS ARE LIVE.
- A MAXIMUM TOLERANCE OF .050/(1.27) ALLOWS FOR 2 POINTS OF ELECTRICAL CONTACT. A MAXIMUM TOLERANCE OF .020/(.51) ALLOWS FOR 4 POINTS OF CONTACT.
- DISCOLORATION IN THE BANDOLIER CARRIER AREA OF THE PIN IS INHERENT TO THE PLATING PROCESS AND IS DUE TO THE MASKING EFFECT OF THE CARRIER. THIS DISCOLORATION IS IN A NON-FUNCTIONAL AREA OF THE PIN AND WILL NOT AFFECT THE PERFORMANCE OF THE HEADER ASSEMBLY..
- PART IS NOT DESIGNED FOR CURRENT SHARING.

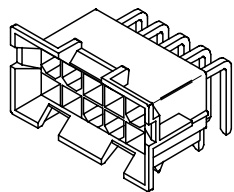

A-42404-****

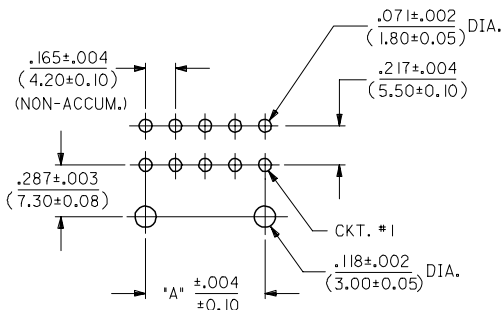

RECOMMENDED HOLE LAYOUT FOR .070/(1.78) MAX. THICK P.C. BOARD VIEWED FROM COMPONENT SIDE

LEGEND:

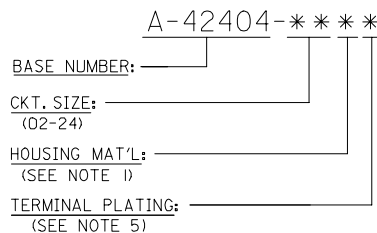

Part	Part No.	Material	Plating	
C	---B2, _**B4	42474-**2I, 5556-PBGS*P	94V-0	
	---A2, _**A4	42474-**1I, 5556-PBGS*P	94V-2	
	---B1, _**B3	42474-**2I, 5556-PBS*P	94V-0	
	---A1, _**A3	42474-**1I, 5556-PBS*P	94V-2	
	---B2, _**B4	42474-**2I, 5556-GS*P	94V-0	
	---A2, _**A4	42474-**1I, 5556-GS*P	94V-2	
B	---B1, _**B3	42474-**2I, 5556-S*P	94V-0	
	---A1, _**A3	42474-**1I, 5556-S*P	94V-2	
	---B2, _**B4	A-42385-**D2	94V-0	
	---A2, _**A4	A-42385-**C2	94V-2	
	---B1, _**B3	A-42385-**D1	94V-0	
	---A1, _**A3	A-42385-**C1	94V-2	
A	---B2, _**B4	A-42385-**B2	94V-0	
	---A2, _**A4	A-42385-**A2	94V-2	
	---B1, _**B3	A-42385-**B1	94V-0	
	---A1, _**A3	A-42385-**A1	94V-2	
	R.A. HEADER	A-42404	MATING CONNECTOR	HSG. MAT'L, TERM. MAT'L, PLATING
	MATING CONNECTOR MATING CONNECTOR FEATURES			

ADDED SHEET 4 EC NO: UCP2006-1780 DRAWN: ADRAINOL 2006/02/03 CHKD: GPOLGAR 2006/02/03 APPR: ICOMERCJ 2006/02/06	QUALITY SYMBOLS ▽=0 ▽=0	GENERAL TOLERANCES (UNLESS SPECIFIED) mm INCH 4 PLACES ± --- ± --- 3 PLACES ± --- ± .010 2 PLACES ± 0.25 ± .015 1 PLACE ± 0.38 ± --- ANGULAR ±1/2°	DIMENSION STYLE IN/MM DRAWN BY DATE RWK 2/7/89 CHECKED BY DATE RJF 2/7/89 APPROVED BY DATE RAS 2/7/89	SCALE 2:1 DESIGN UNITS METRIC THIRD ANGLE PROJECTION	TITLE MINI-FIT JR. 2-24 CKT RIGHT ANGLE HEADER ASSY (BLIND MATE)	MATERIAL NO. DOCUMENT NO. SHEET NO. 1 OF 4	
		DRAFT WHERE APPLICABLE MUST REMAIN WITHIN DIMENSIONS			SEE SHTS 3&4 SDA-42404-****		MOLEX INCORPORATED
		THIS DRAWING CONTAINS INFORMATION THAT IS PROPRIETARY TO MOLEX INCORPORATED AND SHOULD NOT BE USED WITHOUT WRITTEN PERMISSION					
		R.A. HEADER A-42404 MATING CONNECTOR HSG. MAT'L, TERM. MAT'L, PLATING MATING CONNECTOR FEATURES					

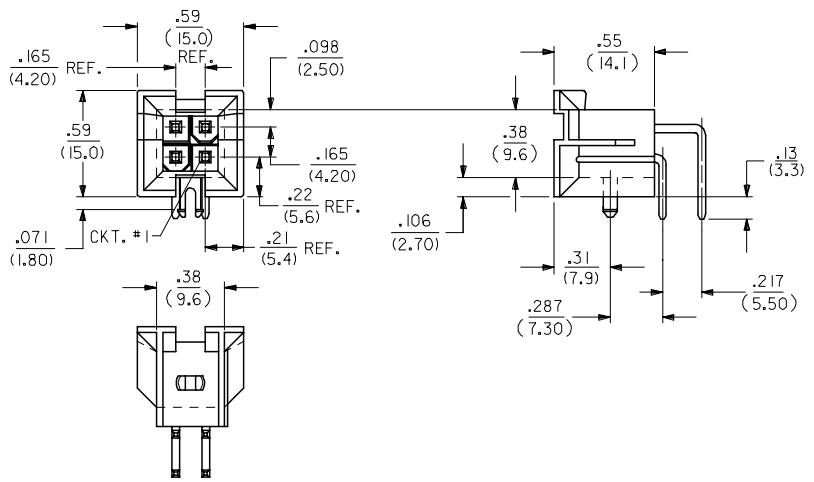

A-42404-04**

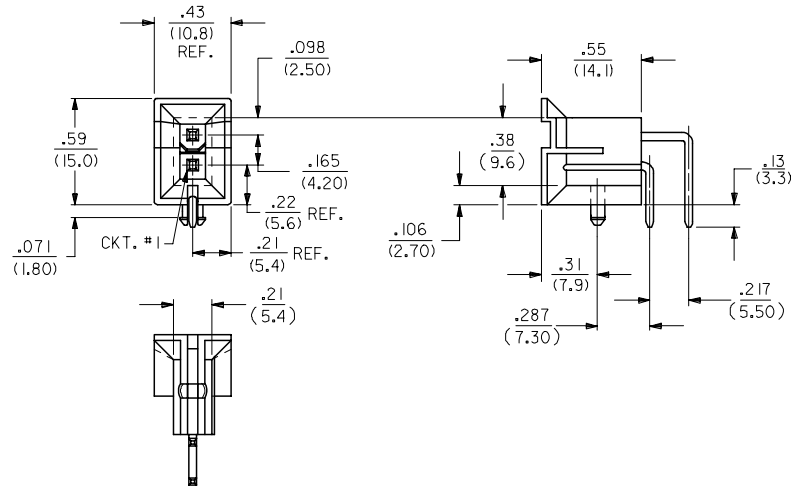

A-42404-02**

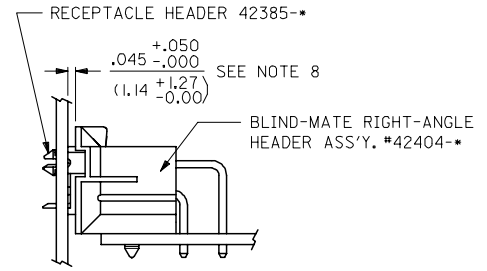
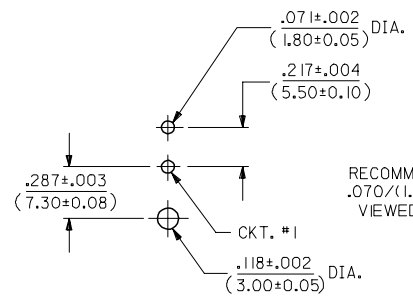
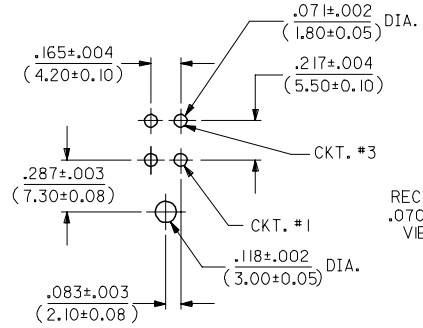

SEE SHEET 1 FC NO: UCP2006-1780 DRW:ADRAINOL 2006/02/03 CHKD:GPOLGAR 2006/02/03 APPR:ICOMERCJ 2006/02/06 REV DESCRIPTION	QUALITY SYMBOLS	GENERAL TOLERANCES (UNLESS SPECIFIED)	DIMENSION STYLE	SCALE	DESIGN UNITS	THIRD ANGLE PROJECTION
	$\nabla=0$ $\nabla=0$	mm INCH 4 PLACES ± --- ± --- 3 PLACES ± --- ± .01 2 PLACES ± 0.25 ± .015 1 PLACE ± 0.38 ± --- ANGULAR ±1/2°	IN/MM	2:1	METRIC	
	DRAWN BY: RWK CHECKED BY: RJF APPROVED BY: RAS MATERIAL NO.: DATE: 1989/02/07	DATE: 1989/02/07 DATE: 1989/02/07 DATE: 1989/02/07	TITLE			MINI-FIT JR. 2-24 CKT RIGHT ANGLE HEADER ASSY (BLIND MATE)
	DRAFT WHERE APPLICABLE MUST REMAIN WITHIN DIMENSIONS	SEE SHTS 3&4 SIZE: C THIS DRAWING CONTAINS INFORMATION THAT IS PROPRIETARY TO MOLEX INCORPORATED AND SHOULD NOT BE USED WITHOUT WRITTEN PERMISSION	MOLEX MOLEX INCORPORATED	DOCUMENT NO.: SDA-42404-****	SHEET NO.: 2 OF 4	

J	I	H	G	F	E	D	C	B	A
PLATING (NOTE 5)	HOUSING MATERIAL	CKT. SIZE	ENG. NUMBER	PART NUMBER	PLATING (NOTE 5)	HOUSING MATERIAL	CKT. SIZE	ENG. NUMBER	PART NUMBER
TIN-LEAD/NICKEL	94V-2	2	A-42404-02A3	NOT TOOLED	TIN OVER NICKEL	94V-2	2	A-42404-02A1	NOT TOOLED
		4	-04A3	15-24-6040			4	-04A1	15-24-6040
		6	-06A3	15-24-6060			6	-06A1	15-24-6060
		8	-08A3	NOT TOOLED			8	-08A1	NOT TOOLED
		10	-10A3	15-24-6100			10	-10A1	15-24-6100
		12	-12A3	NOT TOOLED			12	-12A1	NOT TOOLED
		14	-14A3	15-24-6140			14	-14A1	15-24-6140
		16	-16A3	NOT TOOLED			16	-16A1	NOT TOOLED
		18	-18A3	15-24-6180			18	-18A1	15-24-6180
		20	-20A3	NOT TOOLED			20	-20A1	NOT TOOLED
		22	-22A3	NOT TOOLED			22	-22A1	NOT TOOLED
TIN-LEAD/NICKEL	94V-2	24	A-42404-24A3	15-24-6240	TIN OVER NICKEL	94V-2	24	A-42404-24A1	15-24-6240
		2	A-42404-02A4	NOT TOOLED			2	A-42404-02A2	NOT TOOLED
50 M.I. GOLD	94V-2	4	-04A4	15-24-9046	30 M.I. GOLD	94V-2	4	-04A2	15-24-9043
		6	-06A4	NOT TOOLED			6	-06A2	15-24-9063
		8	-08A4	NOT TOOLED			8	-08A2	NOT TOOLED
		10	-10A4	NOT TOOLED			10	-10A2	15-24-9103
		12	-12A4	NOT TOOLED			12	-12A2	NOT TOOLED
		14	-14A4	NOT TOOLED			14	-14A2	15-24-9143
		16	-16A4	NOT TOOLED			16	-16A2	NOT TOOLED
		18	-18A4	NOT TOOLED			18	-18A2	15-24-9183
		20	-20A4	NOT TOOLED			20	-20A2	NOT TOOLED
		22	-22A4	NOT TOOLED			22	-22A2	NOT TOOLED
50 M.I. GOLD	94V-2	24	A-42404-24A4	15-24-9243	30 M.I. GOLD	94V-2	24	A-42404-24A2	15-24-9243
		2	A-42404-02B4	NOT TOOLED			2	A-42404-02B1	NOT TOOLED
50 M.I. GOLD	94V-0	4	-04B4	15-24-9044	TIN OVER NICKEL	94V-0	4	-04B1	15-24-9044
		6	-06B4	15-24-9064			6	-06B1	15-24-9064
		8	-08B4	NOT TOOLED			8	-08B1	NOT TOOLED
		10	-10B4	15-24-9104			10	-10B1	15-24-9104
		12	-12B4	NOT TOOLED			12	-12B1	NOT TOOLED
		14	-14B4	15-24-9144			14	-14B1	15-24-9144
		16	-16B4	15-24-9164			16	-16B1	15-24-9164
		18	-18B4	15-24-9184			18	-18B1	15-24-9184
		20	-20B4	NOT TOOLED			20	-20B1	NOT TOOLED
		22	-22B4	NOT TOOLED			22	-22B1	NOT TOOLED
50 M.I. GOLD	94V-0	24	A-42404-24B4	15-24-9244	TIN OVER NICKEL	94V-0	24	A-42404-24B1	15-24-9244
		2	A-42404-02B2	NOT TOOLED			2	A-42404-02B2	NOT TOOLED
		4	-04B2	15-24-9045	30 M.I. GOLD	94V-0	4	-04B2	15-24-9045
		6	-06B2	15-24-9065			6	-06B2	15-24-9065
		8	-08B2	NOT TOOLED			8	-08B2	NOT TOOLED
		10	-10B2	15-24-9105			10	-10B2	15-24-9105
		12	-12B2	NOT TOOLED			12	-12B2	NOT TOOLED
		14	-14B2	15-24-9145			14	-14B2	15-24-9145
		16	-16B2	15-24-9165			16	-16B2	15-24-9165
		18	-18B2	15-24-9185			18	-18B2	15-24-9185
		20	-20B2	NOT TOOLED			20	-20B2	NOT TOOLED
		22	-22B2	NOT TOOLED			22	-22B2	NOT TOOLED
		24	A-42404-24B2	15-24-9245	30 M.I. GOLD	94V-0	24	A-42404-24B2	15-24-9245

SEE SHEET 1
 FC NO: UCP2006-1780
 DRAWN: ADRA1NOL 2006/02/03
 CHKD: GPOLGAR 2006/02/03
 APPR: ICOMERCI 2006/02/06

QUALITY SYMBOLS

 GENERAL TOLERANCES (UNLESS SPECIFIED)

	mm	INCH
4 PLACES	± .15	± .005
3 PLACES	± .10	± .004
2 PLACES	± .07	± .003
1 PLACE	± .05	± .002

 ANGULAR ±1/2°
 DRAFT WHERE APPLICABLE
 MUST REMAIN WITHIN DIMENSIONS

DIMENSION STYLE
 IN/MM
 DRAWN BY: RWK DATE: 1989/02/08
 CHECKED BY: RWF DATE: 1989/02/08
 APPROVED BY: RAS DATE: 1989/02/08
 MATERIAL NO.
 SEE CHARTS

SCALE: ---
 DESIGN UNITS: METRIC
 THIRD ANGLE PROJECTION
 MINI-FIT JR. 2-24 CKT
 RIGHT ANGLE HEADER ASSY
 (BLIND MATE)
 MOLEX MOLEX INCORPORATED
 MATERIAL NO. SDA-42404-****
 SHEET NO. 3 OF 4
 THIS DRAWING CONTAINS INFORMATION THAT IS PROPRIETARY TO MOLEX INCORPORATED AND SHOULD NOT BE USED WITHOUT WRITTEN PERMISSION