

CIRCUIT SIZE	DIM. 'A'	DIM. 'B'
6	.331 (8.40)	.76 (19.2)
8	.496 (12.60)	.92 (23.4)
10	.661 (16.80)	1.09 (27.6)
12	.827 (21.00)	1.25 (31.8)
14	.992 (25.20)	1.42 (36.0)
16	1.157 (29.40)	1.58 (40.2)
18	1.323 (33.60)	1.75 (44.4)
20	1.488 (37.80)	1.91 (48.6)
22	1.654 (42.00)	2.08 (52.8)
24	1.819 (46.20)	2.24 (57.0)

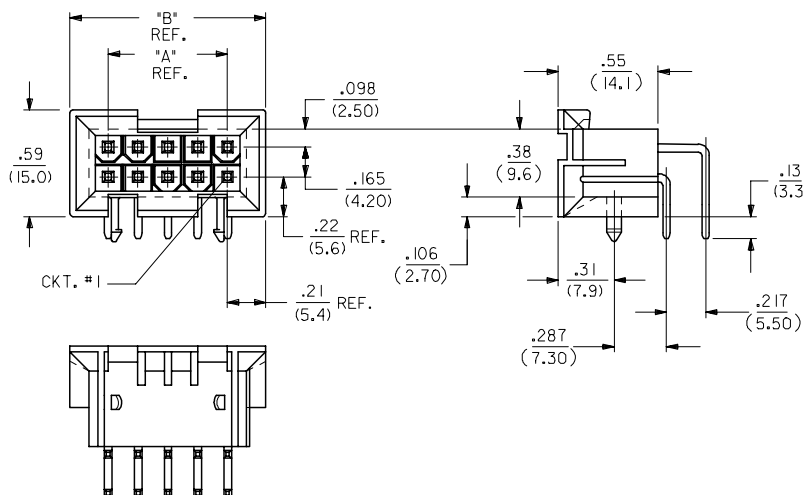

NOTES:

- HOUSING MATERIAL: "A" = NYLON 6/6, U.L. 94V-2, COLOR: NATURAL.
"B" = NYLON 6/6, U.L. 94V-0, COLOR: NATURAL.
- TERMINAL MATERIAL: BRASS, ALLOY 260.
- 4-24 CKT. PARTS MATE WITH MINI-FIT JR. RECEPTACLES #5557, #42385 AND #42474. 2 CKT. PART MATES WITH #42385 AND #42474 ONLY.
- PART ALLOWS FOR UP TO .100/(2.54) MISALIGNMENT WITH MATING RECEPTACLE IN ANY DIRECTION. SEE MATING CONNECTOR DRAWINGS FOR SPECIFIC ALLOWANCES.
- TERMINAL PLATING:
 - .000100/(.00254) MIN. BRIGHT TIN OVER .000050/(.00127) MIN. NICKEL OVERALL.
 - .000030/(.00076) MIN. GOLD OVER .000050/(.00127) MIN. NICKEL OVERALL.
 - .000100/(.00254) MIN. MATTE TIN OVER .000050/(.00127) MIN. NICKEL OVERALL.
 - .000050/(.00127) MIN. GOLD OVER .000050/(.00127) MIN. NICKEL OVERALL.
 - .000030/(.00076) MIN. GOLD AND .000100/(.00254) MIN. MATTE TIN OVER .000050/(.00127) MIN. NICKEL OVERALL.

*THE PRIMARY SHIPPING CARTON WILL BE LABELED "COMPLIANT TO RoHS DIRECTIVE 2002/95/EC AND ELV ANNEX II OF DIRECTIVE 2000/53/EC." CARTONS WITHOUT THIS LABEL MAY CONTAIN PRODUCT WITH TIN-LEAD PLATING.
- PRODUCT SPECIFICATION AND PROCESSING PARAMETERS: SEE PS-5556-002
- CONNECTOR ASSEMBLIES ARE NOT TO BE MATED OR UNMATED WHILE CIRCUITS ARE LIVE.
- A MAXIMUM TOLERANCE OF .050/(1.27) ALLOWS FOR 2 POINTS OF ELECTRICAL CONTACT. A MAXIMUM TOLERANCE OF .020/(.51) ALLOWS FOR 4 POINTS OF CONTACT.
- DISCOLORATION IN THE BANDOLIER CARRIER AREA OF THE PIN IS INHERENT TO THE PLATING PROCESS AND IS DUE TO THE MASKING EFFECT OF THE CARRIER. THIS DISCOLORATION IS IN A NON-FUNCTIONAL AREA OF THE PIN AND WILL NOT AFFECT THE PERFORMANCE OF THE HEADER ASSEMBLY..
- PART IS NOT DESIGNED FOR CURRENT SHARING.

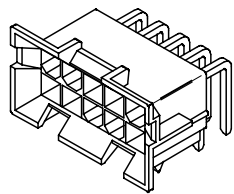

A-42404-****

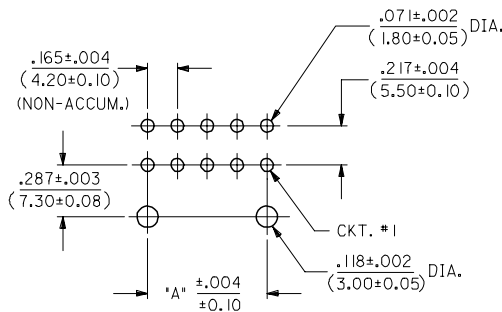

RECOMMENDED HOLE LAYOUT FOR .070/(1.78) MAX. THICK P.C. BOARD VIEWED FROM COMPONENT SIDE

LEGEND:

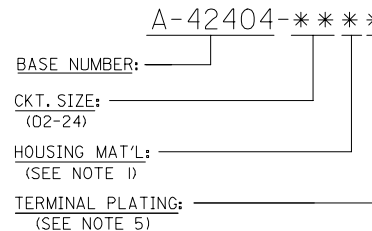

Part No.	Part Description	Material	Plating
---B2, _**B4	42474-**2I, 5556-PBGS*P	94V-0	GOLD
---A2, _**A4	42474-**1I, 5556-PBGS*P	94V-2	PHOS. BRZ.
---B1, _**B3	42474-**2I, 5556-PBS*P	94V-0	TIN
---A1, _**A3	42474-**1I, 5556-PBS*P	94V-2	PHOS. BRZ.
---B2, _**B4	42474-**2I, 5556-GS*P	94V-0	GOLD
---A2, _**A4	42474-**1I, 5556-GS*P	94V-2	BRASS
---B1, _**B3	42474-**2I, 5556-S*P	94V-0	TIN
---A1, _**A3	42474-**1I, 5556-S*P	94V-2	PHOS. BRZ.
---B2, _**B4	A-42385-**D2	94V-0	GOLD
---A2, _**A4	A-42385-**C2	94V-2	PHOS. BRZ.
---B1, _**B3	A-42385-**D1	94V-0	TIN
---A1, _**A3	A-42385-**C1	94V-2	PHOS. BRZ.
---B2, _**B4	A-42385-**B2	94V-0	GOLD
---A2, _**A4	A-42385-**A2	94V-2	BRASS
---B1, _**B3	A-42385-**B1	94V-0	TIN
---A1, _**A3	A-42385-**A1	94V-2	PHOS. BRZ.

ADDED SHEET 4 EC NO: UCP2006-1780 DRAWN: ADRAINOL 2006/02/03 CHKD: GPOLGAR 2006/02/03 APPR: ICOMERCJ 2006/02/06	QUALITY SYMBOLS ▽=0 ▽=0	GENERAL TOLERANCES (UNLESS SPECIFIED) mm INCH 4 PLACES ± --- ± --- 3 PLACES ± --- ± .010 2 PLACES ± 0.25 ± .015 1 PLACE ± 0.38 ± --- ANGULAR ±1/2°		DIMENSION STYLE IN/MM DRAWN BY DATE RWK 2/7/89 CHECKED BY DATE RJF 2/7/89 APPROVED BY DATE RAS 2/7/89		SCALE 2:1	DESIGN UNITS METRIC	THIRD ANGLE PROJECTION
		MINI-FIT JR. 2-24 CKT RIGHT ANGLE HEADER ASSY (BLIND MATE)						
		MOLEX MOLEX INCORPORATED						
		DRAFT WHERE APPLICABLE MUST REMAIN WITHIN DIMENSIONS SEE SHTS 3&4 SDA-42404-**** THIS DRAWING CONTAINS INFORMATION THAT IS PROPRIETARY TO MOLEX INCORPORATED AND SHOULD NOT BE USED WITHOUT WRITTEN PERMISSION						

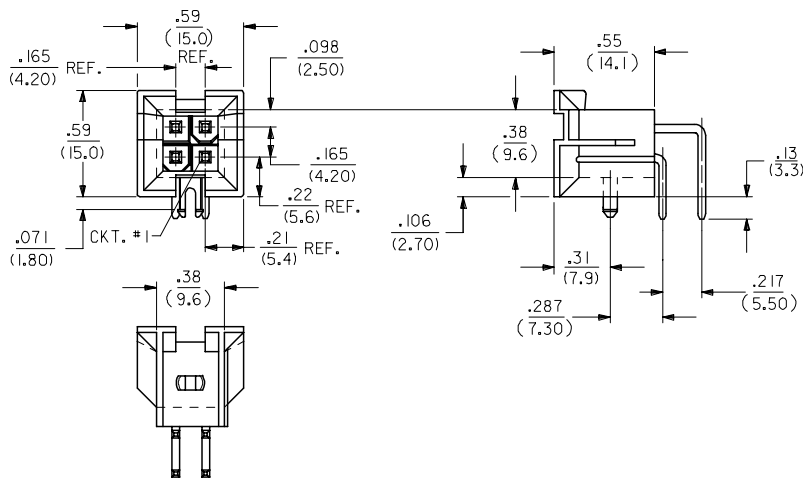

A-42404-04**

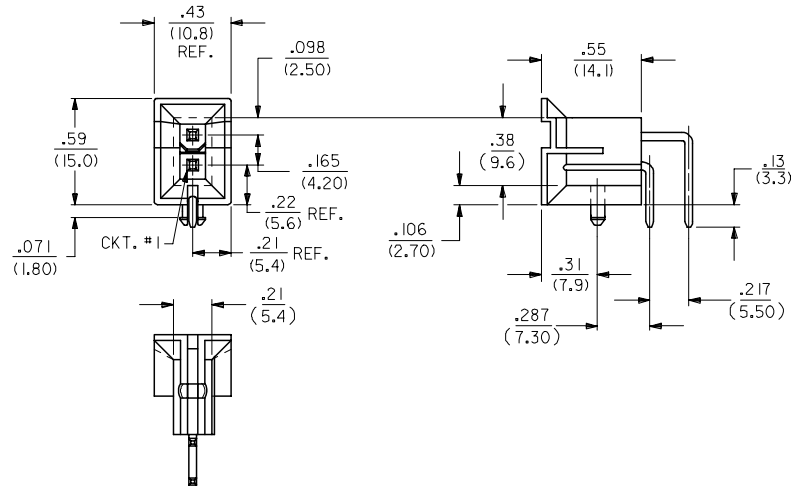

A-42404-02**

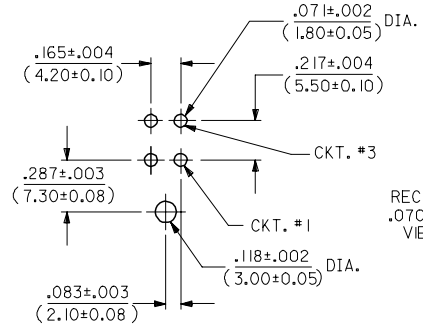

RECOMMENDED HOLE LAYOUT FOR
.070/(1.78) MAX. THICK P.C. BOARD
VIEWED FROM COMPONENT SIDE

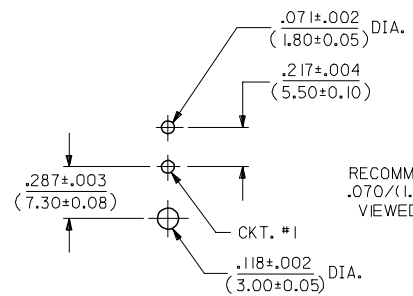

RECOMMENDED HOLE LAYOUT FOR
.070/(1.78) MAX. THICK P.C. BOARD
VIEWED FROM COMPONENT SIDE

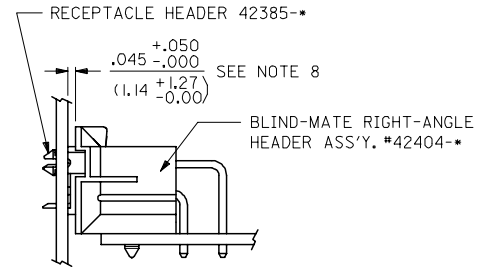

PANEL-TO-P.C.BOARD

SEE SHEET 1 FC NO: UCP2006-1780 DRAWN: ADRIANOL 2006/02/03 CHKD: GPOLGAR 2006/02/03 APPR: ICOMERCJ 2006/02/06 REV:	QUALITY SYMBOLS ▽=0 ▽=0	GENERAL TOLERANCES (UNLESS SPECIFIED) mm INCH 4 PLACES ± .01 ± .01 3 PLACES ± .01 ± .01 2 PLACES ± 0.25 ± .015 1 PLACE ± 0.38 ± .015 ANGULAR ±1/2°	DIMENSION STYLE IN/MM DRAWN BY DATE RWK 1989/02/07 CHECKED BY DATE RJF 1989/02/07 APPROVED BY DATE RAS 1989/02/07 MATERIAL NO. DOCUMENT NO.	SCALE 2:1 DESIGN UNITS METRIC THIRD ANGLE PROJECTION	TITLE MINI-FIT JR. 2-24 CKT RIGHT ANGLE HEADER ASSY (BLIND MATE)	SHEET NO. 2 OF 4
	DRAFT WHERE APPLICABLE MUST REMAIN WITHIN DIMENSIONS		SEE SHTS 3&4 SDA-42404-****		MOLEX INCORPORATED	SHEET NO. 2 OF 4
	THIS DRAWING CONTAINS INFORMATION THAT IS PROPRIETARY TO MOLEX INCORPORATED AND SHOULD NOT BE USED WITHOUT WRITTEN PERMISSION					
	MOLEX INCORPORATED					

J	I	H	G	F	E	D	C	B	A
PLATING (NOTE 5)	HOUSING MATERIAL	CKT. SIZE	ENG. NUMBER	PART NUMBER	PLATING (NOTE 5)	HOUSING MATERIAL	CKT. SIZE	ENG. NUMBER	PART NUMBER
TIN-LEAD/NICKEL	94V-2	2	A-42404-02A3	NOT TOOLED	TIN OVER NICKEL	94V-2	2	A-42404-02A1	NOT TOOLED
		4	-04A3	15-24-6040			4	-04A1	15-24-6040
		6	-06A3	15-24-6060			6	-06A1	15-24-6060
		8	-08A3	NOT TOOLED			8	-08A1	NOT TOOLED
		10	-10A3	15-24-6100			10	-10A1	15-24-6100
		12	-12A3	NOT TOOLED			12	-12A1	NOT TOOLED
		14	-14A3	15-24-6140			14	-14A1	15-24-6140
		16	-16A3	NOT TOOLED			16	-16A1	NOT TOOLED
		18	-18A3	15-24-6180			18	-18A1	15-24-6180
		20	-20A3	NOT TOOLED			20	-20A1	NOT TOOLED
		22	-22A3	NOT TOOLED			22	-22A1	NOT TOOLED
TIN-LEAD/NICKEL	94V-2	24	A-42404-24A3	15-24-6240	TIN OVER NICKEL	94V-2	24	A-42404-24A1	15-24-6240
		2	A-42404-02A4	NOT TOOLED			2	A-42404-02A2	NOT TOOLED
50 M.I. GOLD	94V-2	4	-04A4	15-24-9046			4	-04A2	15-24-9043
		6	-06A4	NOT TOOLED			6	-06A2	15-24-9063
		8	-08A4	NOT TOOLED			8	-08A2	NOT TOOLED
		10	-10A4	NOT TOOLED			10	-10A2	15-24-9103
		12	-12A4	NOT TOOLED			12	-12A2	NOT TOOLED
		14	-14A4	NOT TOOLED			14	-14A2	15-24-9143
		16	-16A4	NOT TOOLED			16	-16A2	NOT TOOLED
		18	-18A4	NOT TOOLED			18	-18A2	15-24-9183
		20	-20A4	NOT TOOLED			20	-20A2	NOT TOOLED
		22	-22A4	NOT TOOLED			22	-22A2	NOT TOOLED
50 M.I. GOLD	94V-2	24	A-42404-24A4	15-24-9243	30 M.I. GOLD	94V-2	24	A-42404-24A2	15-24-9243
		2	A-42404-02B4	NOT TOOLED			2	A-42404-02B1	NOT TOOLED
50 M.I. GOLD	94V-0	4	-04B4	15-24-9044	TIN OVER NICKEL	94V-0	4	-04B1	15-24-9044
		6	-06B4	15-24-9064			6	-06B1	15-24-9064
		8	-08B4	NOT TOOLED			8	-08B1	NOT TOOLED
		10	-10B4	15-24-9104			10	-10B1	15-24-9104
		12	-12B4	NOT TOOLED			12	-12B1	NOT TOOLED
		14	-14B4	15-24-9144			14	-14B1	15-24-9144
		16	-16B4	15-24-9164			16	-16B1	15-24-9164
		18	-18B4	15-24-9184			18	-18B1	15-24-9184
		20	-20B4	NOT TOOLED			20	-20B1	NOT TOOLED
		22	-22B4	NOT TOOLED			22	-22B1	NOT TOOLED
50 M.I. GOLD	94V-0	24	A-42404-24B4	15-24-9244	TIN OVER NICKEL	94V-0	24	A-42404-24B1	15-24-9244
		2	A-42404-02B2	NOT TOOLED			2	A-42404-02B2	NOT TOOLED
		4	-04B2	15-24-9045			4	-04B2	15-24-9045
		6	-06B2	15-24-9065			6	-06B2	15-24-9065
		8	-08B2	NOT TOOLED			8	-08B2	NOT TOOLED
		10	-10B2	15-24-9105			10	-10B2	15-24-9105
		12	-12B2	NOT TOOLED			12	-12B2	NOT TOOLED
		14	-14B2	15-24-9145			14	-14B2	15-24-9145
		16	-16B2	15-24-9165			16	-16B2	15-24-9165
		18	-18B2	15-24-9185			18	-18B2	15-24-9185
		20	-20B2	NOT TOOLED			20	-20B2	NOT TOOLED
		22	-22B2	NOT TOOLED			22	-22B2	NOT TOOLED
		24	A-42404-24B2	15-24-9245	30 M.I. GOLD	94V-0	24	A-42404-24B2	15-24-9245

SEE SHEET 1
 FC NO: UCP2006-1780
 DRAWN: ADRA1NOL 2006/02/03
 CHKD: GPOLGAR 2006/02/03
 APPR: ICOMERCI 2006/02/06

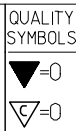

GENERAL TOLERANCES (UNLESS SPECIFIED)	
mm	INCH
4 PLACES	± .005
3 PLACES	± .003
2 PLACES	± .002
1 PLACE	± .001
ANGULAR ±1/2°	

DIMENSION STYLE	
IN/MM	
DRAWN BY	DATE
RWK	1989/02/08
CHECKED BY	DATE
RJF	1989/02/08
APPROVED BY	DATE
RAS	1989/02/08

SCALE: ---
 DESIGN UNITS: METRIC
 THIRD ANGLE PROJECTION

MINI-FIT JR. 2-24 CKT
 RIGHT ANGLE HEADER ASSY
 (BLIND MATE)

molex MOLEX INCORPORATED
 MATERIAL NO. SDA-42404-****
 SHEET NO. 3 OF 4

DRAFT WHERE APPLICABLE
 MUST REMAIN WITHIN DIMENSIONS

SEE CHARTS
 THIS DRAWING CONTAINS INFORMATION THAT IS PROPRIETARY TO MOLEX INCORPORATED AND SHOULD NOT BE USED WITHOUT WRITTEN PERMISSION