

NOTES:

- 1) MATERIALS:  
HOUSING: GLASS FILLED POLYESTER, UL94 V-0, COLOR: BLACK  
TERMINALS: PHOSPHOR BRONZE
- 2) FINISH:  
TERMINALS:  
(A) SELECT GOLD IN CONTACT AREA: 50 MICROINCHES (1.27 MICROMETERS) MIN.,  
\*SELECT TIN IN PC TAIL AREA: 100 MICROINCHES (2.54 MICROMETERS) MIN.,  
WITH OVERALL NICKEL UNDERPLATE: 50 MICROINCHES (1.27 MICROMETERS) MIN.  
(B) SELECT GOLD IN CONTACT AREA: 30 MICROINCHES (0.76 MICROMETERS) MIN.,  
\*SELECT TIN IN PC TAIL AREA: 100 MICROINCHES (2.54 MICROMETERS) MIN.,  
WITH OVERALL NICKEL UNDERPLATE: 50 MICROINCHES (1.27 MICROMETERS) MIN.  
(C) SELECT GOLD IN CONTACT AREA: 15 MICROINCHES (0.38 MICROMETERS) MIN.,  
\*SELECT TIN IN PC TAIL AREA: 100 MICROINCHES (2.54 MICROMETERS) MIN.,  
WITH OVERALL NICKEL UNDERPLATE: 50 MICROINCHES (1.27 MICROMETERS) MIN.  
\*THE PRIMARY SHIPPING CARTON WILL BE LABELED 'COMPLIANT TO RoHS'  
DIRECTIVE 2002/95/EC AND ELV ANNEX II OF DIRECTIVE 2000/53/EC.'  
CARTONS WITHOUT THIS LABEL MAY CONTAIN PRODUCT WITH TIN-LEAD  
IN THE PC TAIL AREA.
- 3) ALL JACKS MUST MEET THE REQUIREMENTS OF MOLEX SPECIFICATION #PS-41314.
- 4) PACKAGING OPTIONS: THERMOFORMED TRAYS PER PK-41369-004 OR TUBES PER PK-41369-005
- 5) JACKS CONFORM TO AND ACCEPT PLUGS WHICH CONFORM TO FCC REGULATIONS, PART 68.5.
- 6) JACKS ARE TO BE USED WITH .062/(1.57) THICK PRINTED CIRCUIT BOARDS.
- 7) SEE SHEET 3 FOR RECOMMENDED PANEL CUT-OUT AND BOARD LAYOUT DIMENSIONS.
- 8) PANEL TO BE LOCATED AGAINST MODULAR JACK FLANGE AS INDICATED.
- 9) ALL UNTOLERANCED DIMENSIONS ARE SHOWN FOR REFERENCE ONLY.

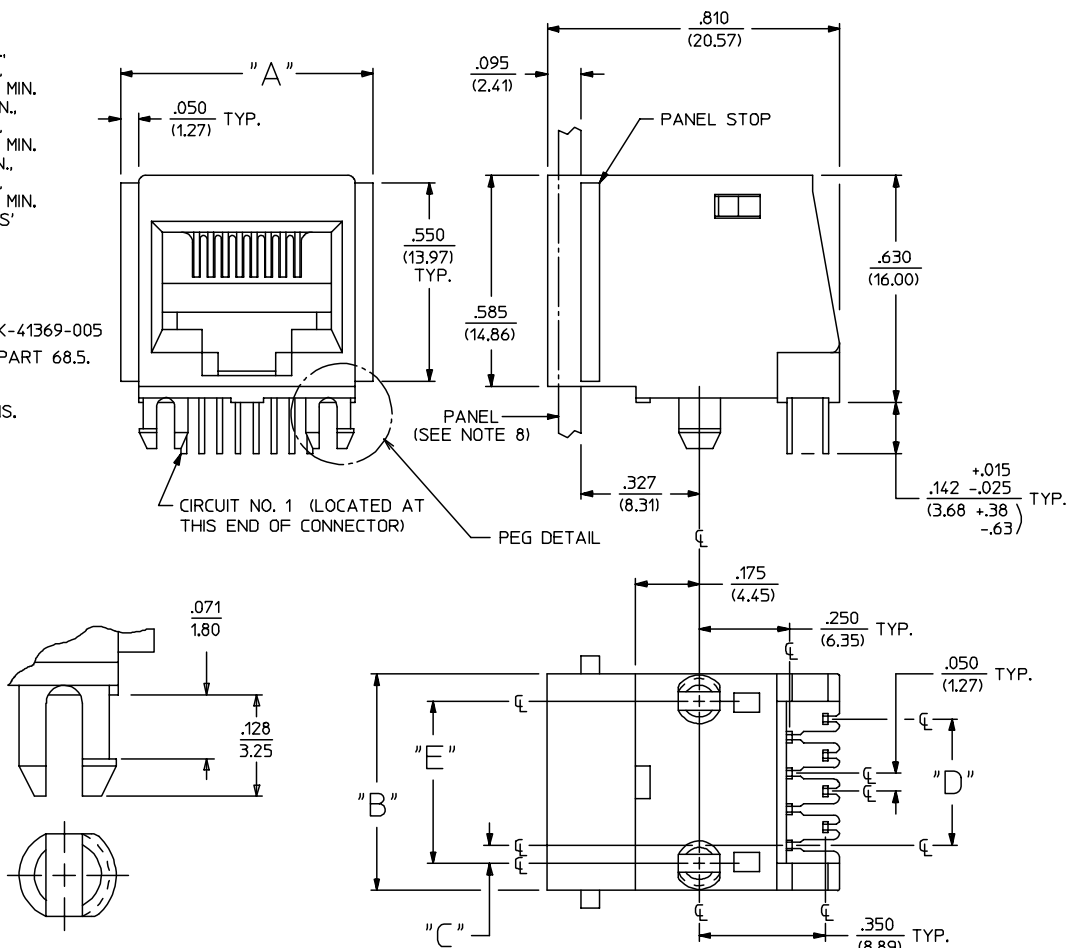

PEG DETAIL  
SCALE: 8:1

SIZE 8 MODULAR JACK HOUSING LOADED WITH 8 TERMINALS IS SHOWN ABOVE

8	2	.700 (17.78)	.600 (15.24)	.200 (5.08)	.050 (1.27)	.450 (11.43)
8	4	.700 (17.78)	.600 (15.24)	.150 (3.81)	.150 (3.81)	.450 (11.43)
8	6	.700 (17.78)	.600 (15.24)	.100 (2.54)	.250 (6.35)	.450 (11.43)
8	8	.700 (17.78)	.600 (15.24)	.050 (1.27)	.350 (8.89)	.450 (11.43)
6	2	.620 (15.75)	.520 (13.21)	.175 (4.45)	.050 (1.27)	.400 (10.16)
6	4	.620 (15.75)	.520 (13.21)	.125 (3.18)	.150 (3.81)	.400 (10.16)
6	6	.620 (15.75)	.520 (13.21)	.075 (1.91)	.250 (6.35)	.400 (10.16)
4	2	.540 (13.72)	.440 (11.18)	.125 (3.18)	.050 (1.27)	.300 (7.62)
4	4	.540 (13.72)	.440 (11.18)	.075 (1.91)	.150 (3.81)	.300 (7.62)
HOUSING SIZE	CIRCUIT SIZE	DIM. "A"	DIM. "B"	DIM. "C"	DIM. "D"	DIM. "E"

REMOVE FILM/AMMO PACK FC NO. UCP2006-2453 DRAWN: PRD/2006/06/14 CHKD: LSCHMDT 2006/06/27 APPR: FSMITH 2006/06/29	QUALITY SYMBOLS	GENERAL TOLERANCES (UNLESS SPECIFIED)	SCALE 4:1	DESIGN UNITS INCH	THIRD ANGLE PROJECTION	REVISE ON CAD ONLY	
	DESCRIPTION	mm	INCH	DIMENSION STYLE IN/MM	TITLE		
		4 PLACES ± --- ± ---	3 PLACES ± --- ± ---	DRAWN BY GLT	DATE 1990/05/09	RIGHT ANGLE FLUSH MOUNT MODULAR JACK ASSEMBLY	
		2 PLACES ± --- ± ---	1 PLACE ± --- ± ---	CHECKED BY BAP	DATE 1990/05/09		
ANGULAR ±1/2°	DRAFT WHERE APPLICABLE	MUST REMAIN WITHIN DIMENSIONS	APPROVED BY RAS	DATE 1990/05/09	MATERIAL NO. SEE SHEET 2	DOCUMENT NO. SDA-41369-*****	
V1					SHEET NO. 1 OF 3		

3	V
2	V1
1	V1
SH	REV

	13	12	11	10	9	8	7	6	5	4	3	2	1	
	ENGINEERING PART NUMBER	E.D.P. NUMBER	HOUSING SIZE	CIRCUIT SIZE	PLATING OPTION	PACKAGING OPTION								
J	A-41369-44ABAA	015-43-7544	4	4	(A)	TRAY PACK								J
	A-41369-44CBAA	015-43-7541	4	4	(C)	TRAY PACK								
	A-41369-42ABAA	015-43-7540	4	2	(A)	TRAY PACK								
	A-41369-66ABAA	015-43-7566	6	6	(A)	TRAY PACK								
	A-41369-66BBAA	015-43-7567	6	6	(B)	TRAY PACK								
	A-41369-64ABAA	015-43-7564	6	4	(A)	TRAY PACK								
	A-41369-64BBAA	015-43-7565	6	4	(B)	TRAY PACK								
I	A-41369-62ABAA	015-43-7563	6	2	(A)	TRAY PACK								I
	A-41369-88ABAA	015-43-7588	8	8	(A)	TRAY PACK								
	A-41369-86ABAA	015-43-7586	8	6	(A)	TRAY PACK								
	A-41369-84ABAA	015-43-7584	8	4	(A)	TRAY PACK								
	A-41369-82ABAA	015-43-7580	8	2	(A)	TRAY PACK								
	A-41369-44ACAA	015-43-7546	4	4	(A)	TUBES								
	A-41369-64ACAA	015-43-7570	6	4	(A)	TUBES								
H	A-41369-62ACAA	015-43-7571	6	2	(A)	TUBES								H
G													G	
F													F	
E													E	
D													D	
C													C	
B													B	
A													A	

SEE SHEET ONE EC NO: UCP2006-2453 DRWN: PRIDDER 2006/06/14 CHKD: LSCHMIDT 2006/06/27 APPR: FSMITH 2006/06/29	QUALITY SYMBOLS	GENERAL TOLERANCES (UNLESS SPECIFIED)	SCALE ---	DESIGN UNITS INCH	THIRD ANGLE PROJECTION	REVISE ON CAD ONLY	
	▽ - 0	mm INCH	DIMENSION STYLE IN/MM		TITLE		
	▽ - 0	4 PLACES ± --- ± --- 3 PLACES ± --- ± --- 2 PLACES ± --- ± --- 1 PLACE ± --- ± ---	DRAWN BY GLT	DATE 1990/05/09	RIGHT ANGLE FLUSH MOUNT MODULAR JACK ASSEMBLY		
		ANGULAR ±1/2°	CHECKED BY BAP	DATE 1990/05/09	MOLEX INCORPORATED		
	DRAFT WHERE APPLICABLE MUST REMAIN WITHIN DIMENSIONS	APPROVED BY RAS	DATE 1990/05/09	MATERIAL NO. SEE CHART	DOCUMENT NO. SDA-41369-*****	SHEET NO. 2 OF 3	
		THIS DRAWING CONTAINS INFORMATION THAT IS PROPRIETARY TO MOLEX INCORPORATED AND SHOULD NOT BE USED WITHOUT WRITTEN PERMISSION					

ENGINEERING PART NUMBER	HOUSING SIZE	CIRCUIT SIZE	DIM. "A"	DIM. "B"	DIM. "C"
A-41369-44XXXX	4	4	.455/(11.56)	.300/(7.62)	.150/(3.81)
A-41369-42XXXX	4	2	.455/(11.56)	.300/(7.62)	.050/(1.27)
A-41369-66XXXX	6	6	.535/(13.59)	.400/(10.16)	.250/(6.35)
A-41369-64XXXX	6	4	.535/(13.59)	.400/(10.16)	.150/(3.81)
A-41369-62XXXX	6	2	.535/(13.59)	.400/(10.16)	.050/(1.27)
A-41369-88XXXX	8	8	.615/(15.62)	.450/(11.43)	.350/(8.89)
A-41369-86XXXX	8	6	.615/(15.62)	.450/(11.43)	.250/(6.35)
A-41369-84XXXX	8	4	.615/(15.62)	.450/(11.43)	.150/(3.81)
A-41369-82XXXX	8	2	.615/(15.62)	.450/(11.43)	.050/(1.27)

NOTE: ALL RECOMMENDED BOARD LAYOUTS ARE SHOWN AS COMPONENT SIDE OF BOARD

PC BOARD LAYOUT FOR HOUSING SIZE 8

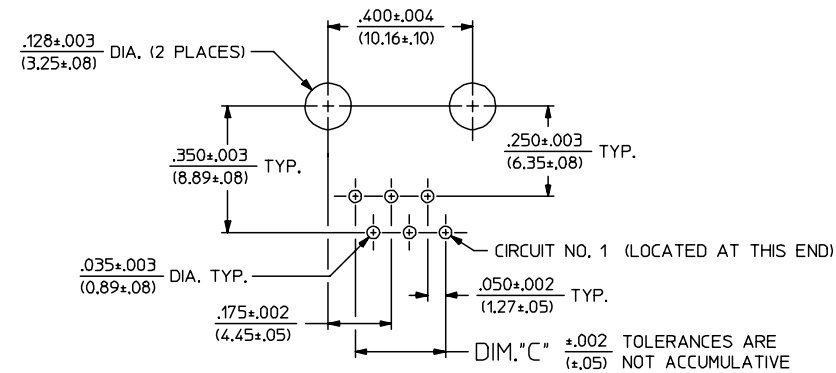

PC BOARD LAYOUT FOR HOUSING SIZE 6

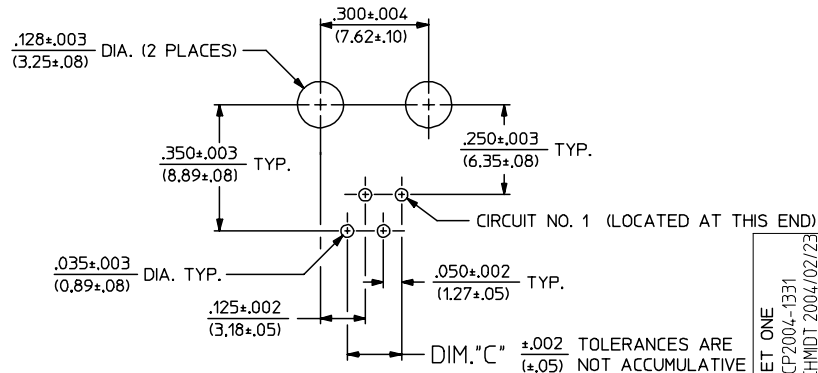

PC BOARD LAYOUT FOR HOUSING SIZE 4

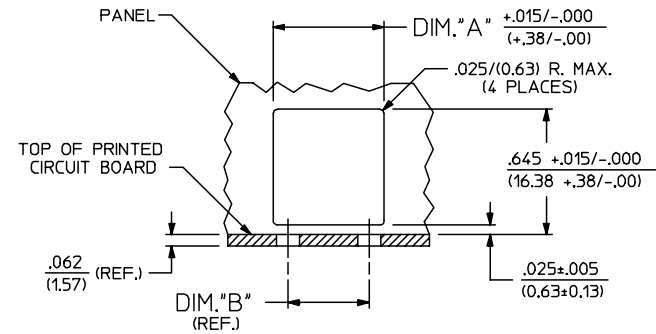

PANEL CUT-OUT GUIDELINES

DIM. "A" MUST BE SYMMETRICAL TO DIM. "B" WITHIN .005/(0.13)

SEE SHEET ONE EC NO: UCP2004-1331 DRWN:LSCHMIDT 2004/02/23 CHKD:LSCHMIDT 2004/02/23 APPR:FSMITH 2004/02/26 REV	QUALITY SYMBOLS ▽ = 0 ▽ = 0	GENERAL TOLERANCES (UNLESS SPECIFIED) <table border="1"> <thead> <tr> <th></th> <th>mm</th> <th>INCH</th> </tr> </thead> <tbody> <tr> <td>4 PLACES</td> <td>± .---</td> <td>± .---</td> </tr> <tr> <td>3 PLACES</td> <td>± .---</td> <td>± .---</td> </tr> <tr> <td>2 PLACES</td> <td>± .---</td> <td>± .---</td> </tr> <tr> <td>1 PLACE</td> <td>± .---</td> <td>± .---</td> </tr> </tbody> </table> ANGULAR ±1/2°		mm	INCH	4 PLACES	± .---	± .---	3 PLACES	± .---	± .---	2 PLACES	± .---	± .---	1 PLACE	± .---	± .---	SCALE 4:1 DESIGN UNITS INCH DIMENSION STYLE IN/MM DRAWN BY GLT DATE 1990/05/09 CHECKED BY BAP DATE 1990/05/09 APPROVED BY RAS DATE 1990/05/09	THIRD ANGLE PROJECTION REVISE ON CAD ONLY TITLE PANEL/BOARD LAYOUTS FOR RIGHT ANGLE FLUSH MOUNT MODULAR JACK ASSEMBLIES MOLEX MOLEX INCORPORATED MATERIAL NO. SEE SHEET 2 DOCUMENT NO. SDA-41369-***** SHEET NO. 3 OF 3
		mm	INCH																
4 PLACES	± .---	± .---																	
3 PLACES	± .---	± .---																	
2 PLACES	± .---	± .---																	
1 PLACE	± .---	± .---																	
DRAFT WHERE APPLICABLE MUST REMAIN WITHIN DIMENSIONS		THIS DRAWING CONTAINS INFORMATION THAT IS PROPRIETARY TO MOLEX INCORPORATED AND SHOULD NOT BE USED WITHOUT WRITTEN PERMISSION																	

# Mouser Electronics

Authorized Distributor

Click to View Pricing, Inventory, Delivery & Lifecycle Information:

## Molex:

[15-43-7540](#) [15-43-7580](#) [15-43-7588](#) [15-43-7563](#) [15-43-7586](#) [15-43-7544](#) [15-43-7564](#) [15-43-7570](#) [15-43-7584](#)  
[15-43-7566](#) [15-43-7064](#)