

Distributed by:

JAMECO[®]
ELECTRONICS

www.Jameco.com ♦ 1-800-831-4242

The content and copyrights of the attached
material are the property of its owner.

Jameco Part Number 794103

FEATURES AND SPECIFICATIONS

Features and Benefits

- Receptacle housing for wire-to-wire and wire-to-board applications
- Terminal Position Assurance (TPA) allows the terminal to be fully seated in the housing assuring that it will not back out during high vibration applications
- Connector Position Assurance (CPA) assures housing cannot be inadvertently disengaged
- Contrasting color (white) TPA/CPA for high visibility
- TPA and CPA keys are sold individually to meet customer-specific needs

Reference Information

Product Specification: PS-5556-0003
 Packaging: Tray and bag
 UL File No.: E29179
 CSA File No.: LR19980
 TUV License No.: R75142
 Use With: Standard Mini-Fit terminals
 Mates With: [30068](#) housing, [30069](#) and [30070](#) headers
 Designed In: Millimeters

Mechanical

Contact Insertion Force: 1.5kg max.
 Contact Retention to Housing: 3.0kg min.
 Wire Pull-Out Force: 9.0kg min.
 Mating Force: 0.7kg (1.54 lb) max.
 Unmating Force: 0.35kg (0.7 lb) min.
 Normal Force: 200g min.
 Durability: 30 cycles

Physical

Housing: Black polyester, UL 94V-0
 Contact: Brass or Phosphor Bronze
 Plating: Tin, select Gold and overall Gold
 Operating Temperature: -40 to +105°C



**4.20mm (.165") Pitch
 Mini-Fit, TPA™
 Receptacle**

30067

**Dual Row
 With Secondary Terminal
 Retention**

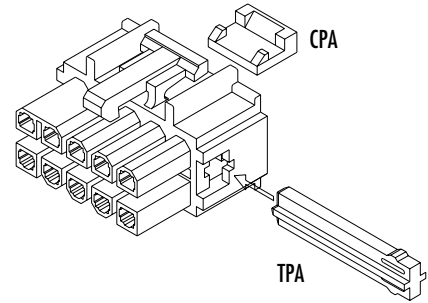

CATALOG DRAWING (FOR REFERENCE ONLY)

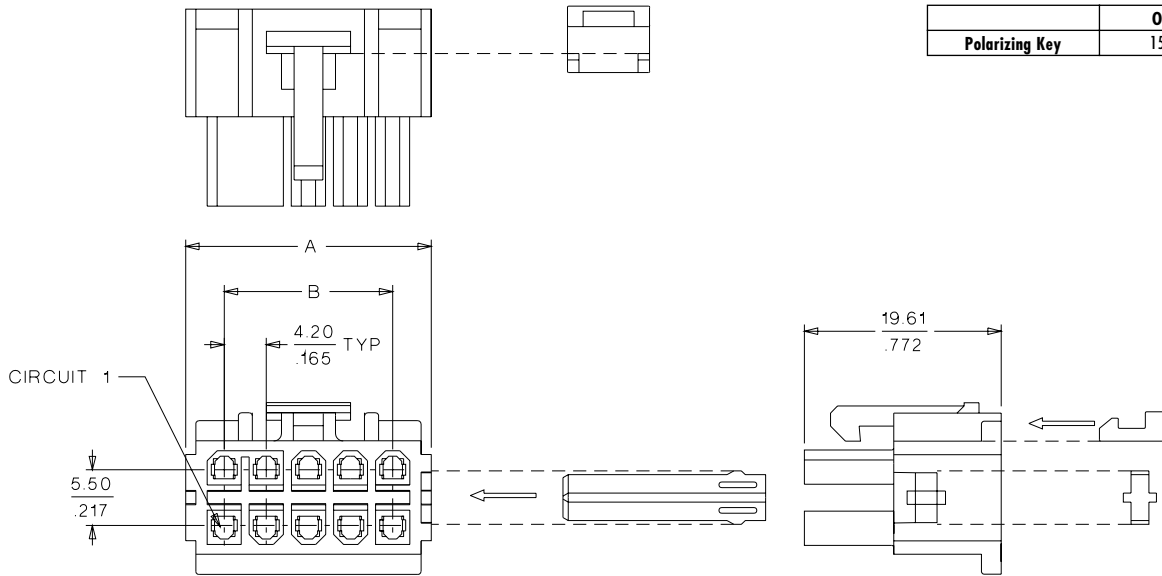

ORDERING INFORMATION AND DIMENSIONS

Circuits	Receptacle Order No.	Receptacle Dimension		Terminal Position Assurance	Connector Position Assurance
		A	B	30072	30071 (Fits All Receptacles)
2	• 15-97-5021*	11.86 (.467)		• 15-97-9041†	• 15-97-0071
4	• 15-97-5041*	11.86 (.467)	4.20 (.165)	• 15-97-9041†	
6	• 15-97-5061*	16.08 (.633)	8.40 (.331)	• 15-97-9061	
8	• 15-97-5081	20.27 (.798)	12.60 (.496)	• 15-97-9081	
10	• 15-97-5101	24.46 (.963)	16.80 (.661)	• 15-97-9101	
12	• 15-97-5121	28.68 (1.129)	21.00 (.827)	• 15-97-9121	
16	• 15-97-5161	37.06 (1.459)	29.40 (1.157)	• 15-97-9161	

• US Standard Product, available through Molex franchised distributors

* Receptacles have side pull tabs for use with strain reliefs

† The same TPA is used for both the 2 and 4 circuit receptacles



PRODUCT SPECIFICATION

MINI-FIT TPA

1.0 SCOPE

This Product Specification covers performance requirements for the MINI-FIT TPA 4.20 mm (.165 inch) centerline (pitch) printed circuit board (PCB) connector series with Tin or Gold plating, and The MINI-FIT TPA connector series terminated with 16 to 28 AWG wire using Crimp technology with Tin or Gold plating.

2.0 PRODUCT DESCRIPTION

2.1 PRODUCT NAME AND SERIES NUMBER (S)

<u>PRODUCT NAME</u>	<u>PART NUMBER</u>
Female Crimp Terminal	5556-****
Male Crimp Terminal	5558-****
Receptacle Housing	30067-****
Plug Housing	30068-****
Vertical Header Assembly	30069-****
Vertical Header Assembly	44482-****
Right Angle Header Assembly	30070-****
Right Angle Header Assembly	44483-****
Terminal Position Assurance Key (TPA)	30072-*
Connector Position Assurance Key (CPA)	30071

2.2 DIMENSIONS, MATERIALS, PLATINGS AND MARKINGS

See the appropriate sales drawings for the information on dimensions, materials, platings and markings.

2.3 SAFETY AGENCY APPROVALS

UL File #E29179
CSA Certificate #LR 19980
TUV Certificate #R75142-8

3.0 APPLICABLE DOCUMENTS AND SPECIFICATIONS

See sales drawings and the other sections of this specification for the necessary referenced documents and specifications

4.0 RATINGS

4.1 VOLTAGE

600 Volts AC (RMS) (or 600 Volts DC)

4.2 CURRENT AND APPLICABLE WIRES

Maximum Insulation Diameter and Applicable Wire Gauges	16 AWG: 3.10/. 122 MAXIMUM
	18-24 AWG: 3.10/. 122 MAXIMUM
	22-28 AWG: 1.80/. 071 MAXIMUM

REVISION: C	ECR/ECN INFORMATION: EC No: UCP2004-0947 DATE: 2003 / 11 / 14	TITLE: PRODUCT SPECIFICATION FOR MINI-FIT TPA CONNECTOR SYSTEM	SHEET No. 1 of 5
DOCUMENT NUMBER: PS-5556-003	CREATED / REVISED BY: M. BANDURA	CHECKED BY: M. BANDURA	APPROVED BY: Y. MARGULIS



PRODUCT SPECIFICATION

4.2 CURRENT AND APPLICABLE WIRES (continued)

MAXIMUM CURRENT RATING (Amperes)									
Brass					Phosphor Bronze				
Wire \ Ckt. Size	2 & 3	4 - 6	7 - 10	12 - 24	Wire \ Ckt. Size	2 & 3	4 - 6	7 - 10	12 - 24
AWG #16	9	8	7	6	AWG #16	8	7	6	5
AWG #18	9	8	7	6	AWG #18	8	7	6	5
AWG #20	7	6	5	5	AWG #20	6	5	4	4
AWG #22	5	4	4	4	AWG #22	4	3	3	3
AWG #24	4	3	3	3	AWG #24	3	2	2	2
AWG #26	3	2	2	2	AWG #26	2	1	1	1
AWG #28	2	1	1	1	AWG #28	1	1	1	1

4.3 TEMPERATURE

Operating: * - 40°C to + 105°C

Nonoperating: - 40°C to + 105°C

*Including 30°C terminal temperature at rated current

5.0 PERFORMANCE

5.1 ELECTRICAL REQUIREMENTS

ITEM	DESCRIPTION	TEST CONDITION	REQUIREMENT
1	Contact Resistance (Low Level)	Mate connectors: apply a maximum voltage of 20 mV and a current of 100 mA. Wire resistance shall be removed from the measured value.	10 milliohms MAXIMUM [initial]
2	Contact Resistance @ Rated Current	Mate connectors: apply a maximum voltage of 20 mV at rated current.	10 milliohms MAXIMUM [initial]
3	Contact Resistance of Wire Termination (Low Level)	Terminate the applicable wire to the terminal and measure wire using a voltage of 20 mV and a current of 100 mA.	5 milliohms MAXIMUM [initial]
4	Insulation Resistance	Mate connectors: apply a voltage of 500 VDC between adjacent terminals and between terminals to ground.	1000 Megohms MINIMUM

REVISION: C	ECR/ECN INFORMATION: EC No: UCP2004-0947 DATE: 2003 / 11 / 14	TITLE: PRODUCT SPECIFICATION FOR MINI-FIT TPA CONNECTOR SYSTEM	SHEET No. 2 of 5
DOCUMENT NUMBER: PS-5556-003	CREATED / REVISED BY: M. BANDURA	CHECKED BY: M. BANDURA	APPROVED BY: Y. MARGULIS



PRODUCT SPECIFICATION

5.1 ELECTRICAL REQUIREMENTS (continued)

ITEM	DESCRIPTION	TEST CONDITION	REQUIREMENT
5	Dielectric Withstanding Voltage	Mate connectors: apply a voltage of 1500 VAC for 1 minute between adjacent terminals and between terminals to ground.	No breakdown. Current leakage < 5 mA
6	Temperature Rise (via Current Cycling)	Mate connectors. Measure the temperature rise at the rated current after 96 hours, during current cycling (45 minutes ON and 15 minutes OFF per hour) for 240 hours, and after final 96-hour steady state.	Temperature rise: +30°C MAXIMUM

5.2 MECHANICAL REQUIREMENTS

ITEM	DESCRIPTION	TEST CONDITION	REQUIREMENT
1	Terminal Mate and Unmate Forces	Insert and withdraw terminal (male to female) at a rate of 25 ± 6 mm (1 ± ¼ inch) per minute.	14.7 N (3.30 lbf) MAXIMUM insertion force & 1.0 N (0.02 lbf) MINIMUM withdrawal force
2	Crimp Terminal Retention Force (in Housing)	Axial pullout force on the terminal in the housing at a rate of 25 ± 6 mm (1 ± ¼ inch) per minute.	30 N (6.74 lbf) MINIMUM retention force
3	Crimp Terminal Retention Force (in Housing With TPA Key)	Axial pullout force on the terminal in the housing at a rate of 25 ± 6 mm (1 ± ¼ inch) per minute.	SECTION 5.2.7
4	Durability	Mate connectors up to 30 cycles at a maximum rate of 10 cycles per minute prior to Environmental Tests.	20 milliohms MAXIMUM
5	Vibration (Random)	Mate connectors and vibrate per EIA 364-28, test condition VII.	10 milliohms MAXIMUM (change from initial) & Discontinuity < 1 microsecond
6	Shock (Mechanical)	Mate connectors and shock at 50 g's with ½ sine wave (11 milliseconds) shocks in the ±X, ±Y, ±Z axes, (18 shocks total).	20 milliohms MAXIMUM & Discontinuity < 1 microsecond

REVISION:	ECR/ECN INFORMATION:	TITLE:	SHEET No.
C	EC No: UCP2004-0947 DATE: 2003 / 11 / 14	PRODUCT SPECIFICATION FOR MINI-FIT TPA CONNECTOR SYSTEM	3 of 5
DOCUMENT NUMBER:	CREATED / REVISED BY:	CHECKED BY:	APPROVED BY:
PS-5556-003	M. BANDURA	M. BANDURA	Y. MARGULIS



PRODUCT SPECIFICATION

5.2 MECHANICAL REQUIREMENTS (continued)

7	Wire Pullout Force (Axial)	Apply an axial pullout force on the wire at a rate of 25 ± 6 mm ($1 \pm \frac{1}{4}$ inch).	16 Awg = 88.0 N (19.8 lbf) Min. 18 Awg = 88.0 N (19.8 lbf) Min. 20 Awg = 59.0 N (13.3 lbf) Min. 22 Awg = 39.0 N (8.78 lbf) Min. 24 Awg = 29.0 N (6.52 lbf) Min. 26 Awg = 19.0 N (4.27 lbf) Min. 28 Awg = 9.80 N (2.20 lbf) Min.
8	Crimp Terminal Insertion Force (into Housing)	Apply an axial insertion force on the terminal at a rate of 25 ± 6 mm ($1 \pm \frac{1}{4}$ inch).	15.0 N (3.37 lbf) MAXIMUM insertion force
9	Normal Force	Apply a perpendicular force.	0.49 N (50 grams) MINIMUM [Gold (noble) plating] OR 1.47 N (150 grams) MINIMUM [Tin (non-noble) plating]
10	PCB Engagement and Separation Forces	Engage and separate a connector at a rate of 25 ± 6 mm ($1 \pm \frac{1}{4}$ inch) per minute. (Applies to parts with PCB retention features only)	49.0 N (11.0 lbf) MAXIMUM insertion force & 10.0 N (2.24 lbf) MINIMUM withdrawal force
12	Receptacle Thumb Latch Strength (CPA not installed)	Mate connectors. Pull connectors apart at a rate of 25 ± 6 mm ($1 \pm \frac{1}{4}$ inch) per minute.	68 N (15.3 lbf)

5.3 ENVIRONMENTAL REQUIREMENTS

ITEM	DESCRIPTION	TEST CONDITION	REQUIREMENT
1	Thermal Shock	Mate connectors: expose for 5 cycles between temperatures -55 and 105°C; dwell 0.5 hours at each temperature.	20 milliohms MAXIMUM Visual: No Damage Dielectric Strength per 5.1.5 Insulation Resistance per 5.1.4
2	Thermal Aging	Mate connectors; expose to: 96 hours at $105 \pm 2^\circ\text{C}$	20 milliohms MAXIMUM & Visual: No Damage
3	Humidity (Steady State)	Mate connectors: expose to a temperature of $60 \pm 2^\circ\text{C}$ with a relative humidity of 90-95% for 96 hours.	20 milliohms MAXIMUM Dielectric Strength per 5.1.5 Insulation Resistance per 5.1.4 Visual: No Damage

REVISION:	ECR/ECN INFORMATION:	TITLE:	SHEET No.
C	EC No: UCP2004-0947 DATE: 2003 / 11 / 14	PRODUCT SPECIFICATION FOR MINI-FIT TPA CONNECTOR SYSTEM	4 of 5
DOCUMENT NUMBER:	CREATED / REVISED BY:	CHECKED BY:	APPROVED BY:
PS-5556-003	M. BANDURA	M. BANDURA	Y. MARGULIS



PRODUCT SPECIFICATION

4	Solderability	Per SMES-152	Solder coverage: 95% MINIMUM (per SMES-152)
---	---------------	--------------	---

5.3 ENVIRONMENTAL REQUIREMENTS (continued)

ITEM	DESCRIPTION	TEST CONDITION	REQUIREMENT
5	Solder Resistance	Dip connector terminal tails in solder: Solder Duration: 5 ± 0.5 seconds; Solder Temperature: 235 ± 5°C	Visual: No Damage to insulator material
6	Cold Resistance	Mate connectors: Duration: 96 hours; Temperature: -40 ± 3°C	20 milliohms MAXIMUM Visual: No Damage
7	Corrosive Atmosphere: Sulfur Dioxide Gas (SO ₂)	Mate connectors: Duration: 24 hours exposure. Atmosphere: 50 parts per million (ppm) SO ₂ Gas. Temperature: 40 ± 3°C	20 milliohms MAXIMUM Visual: No damage

6.0 PACKAGING

Parts shall be packaged to protect against damage during handling, transit and storage.

REVISION: C	ECR/ECN INFORMATION: EC No: UCP2004-0947 DATE: 2003 / 11 / 14	TITLE: PRODUCT SPECIFICATION FOR MINI-FIT TPA CONNECTOR SYSTEM	SHEET No. 5 of 5
DOCUMENT NUMBER: PS-5556-003	CREATED / REVISED BY: M. BANDURA	CHECKED BY: M. BANDURA	APPROVED BY: Y. MARGULIS

13 12 11 10 9 8 7 6 5 4 3 2 1

J
I
H
G
F
E
D
C
B
A

J
I
H
G
F
E
D
C
B
A

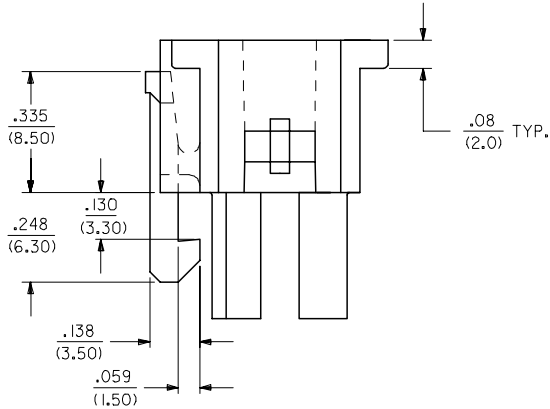
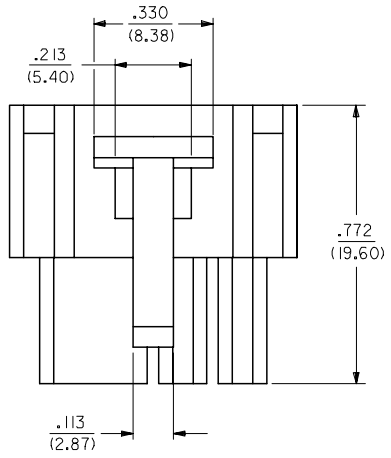
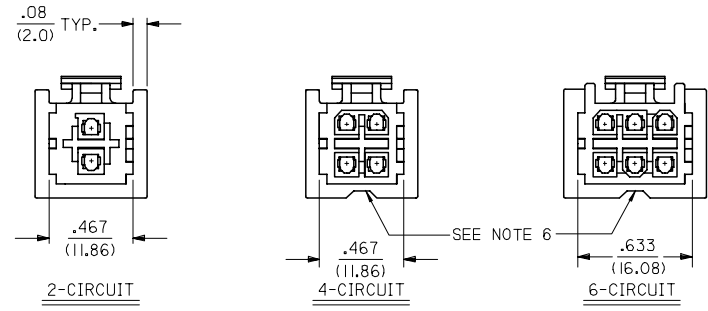
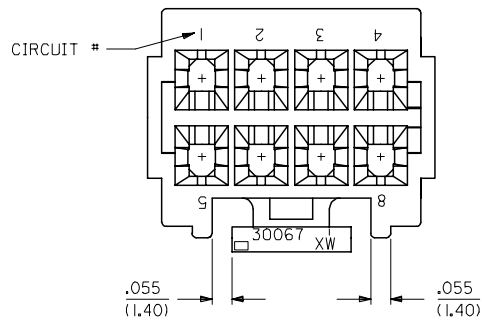

NOTES:

1. MATERIAL: UNFILLED POLYESTER, U.L. 94V-0.
2. HOUSING COLOR:
A = MOLDED BLACK
2. HOUSING TO BE USED WITH TERMINAL #5556, AND T.P.A. LOCK # 30072-*
3. RECEPTACLE HOUSING TO MATE WITH PLUG HOUSING #30068, ST. HEADER #30069, AND RT. ANGLE HEADERS #30070 & #44483.
4. HOUSING ACCEPTS CONNECTOR POSITIONING ASSURANCE (C.P.A.) LOCK # 30071.
5. PRODUCT SPECIFICATION: PS-5556-003.
6. RELIEF NOTCH IS OPTIONAL AND MAY OR MAY NOT APPEAR ON 4 & 6 CIRCUIT HOUSINGS ONLY.

PROTECTIVE SIDES AVAILABLE ON ALL CIRCUITS EXCEPT TWO AND FOUR CIRCUITS.

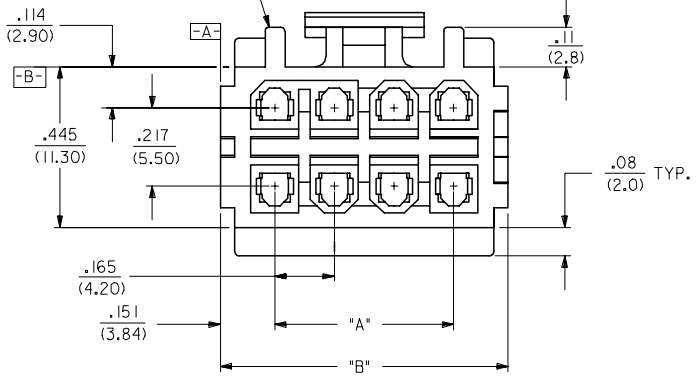

2	G
1	G

ADD NOTCH EC NO: U0P200951M22 G1 DRWN: C STEWART 2004/12/16 CHKD: G POLGAR 2004/12/16 APPR: Y MARGULLI 2004/12/20 REV DESCRIPTION	QUALITY SYMBOLS	GENERAL TOLERANCES (UNLESS SPECIFIED)	DIMENSION STYLE IN/MM	SCALE 4:1	DESIGN UNITS INCH	THIRD ANGLE PROJECTION	
	▽=0 ▽=0	4 PLACES ± --- ± --- 3 PLACES ± --- ± .010 2 PLACES ± 0.25 ± .014 1 PLACE ± 0.36 ± --- ANGULAR ±1/2°	DRAWN BY DATE RJF 09/23/91 CHECKED BY DATE GEP 09/23/91 APPROVED BY DATE RAS 09/23/91	TITLE	2-24 CKT. RECPT. HSG. MINI-FIT T.P.A. SERIES		
		DRAFT WHERE APPLICABLE MUST REMAIN WITHIN DIMENSIONS	SEE CHART	MATERIAL NO.	DOCUMENT NO.	SHEET NO.	
				SD-30067-*	1 OF 2		

MOLEX INCORPORATED

12 11 10 9 8 7 6 5 4 3 2 1

CKT. SIZE	ENG. NO.	EDP. NO.	DIM. "A"	DIM. "B"
02	30067-02A2	15-97-5021	—	.467 (11.86)
04	30067-04A2	15-97-5041	.165 (4.20)	.467 (11.86)
06	30067-06A2	15-97-5061	.331 (8.40)	.633 (16.08)
08	30067-08A2	15-97-5081	.496 (12.60)	.798 (20.27)
10	30067-10A2	15-97-5101	.661 (16.80)	.963 (24.46)
12	30067-12A2	15-97-5121	.827 (21.00)	1.129 (28.68)
14	30067-14A2	NOT TOOLED	.992 (25.20)	1.294 (32.87)
16	30067-16A2	15-97-5161	1.157 (29.40)	1.459 (37.06)
18	30067-18A2	NOT TOOLED	1.520 (38.60)	1.822 (46.28)
20	30067-20A2	NOT TOOLED	1.685 (42.80)	1.987 (50.46)
22	30067-22A2	NOT TOOLED	1.850 (47.00)	2.152 (54.66)
24	30067-24A2	NOT TOOLED	2.016 (51.20)	2.318 (58.88)

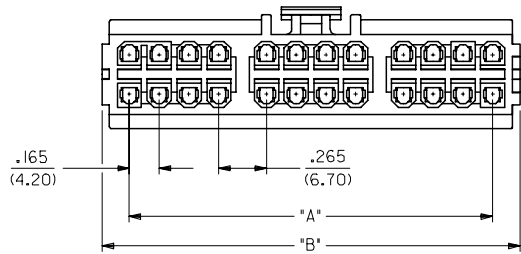

24 CIRCUIT

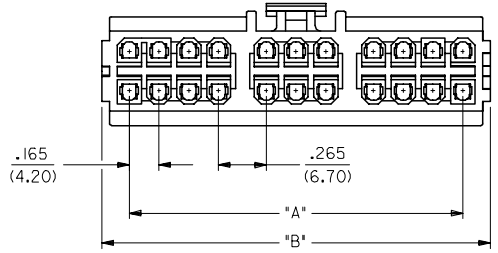

22 CIRCUIT

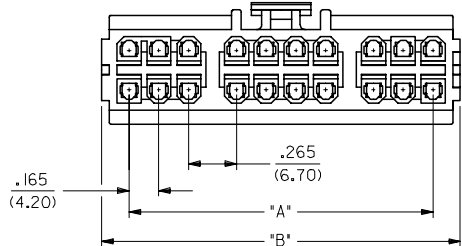

20 CIRCUIT

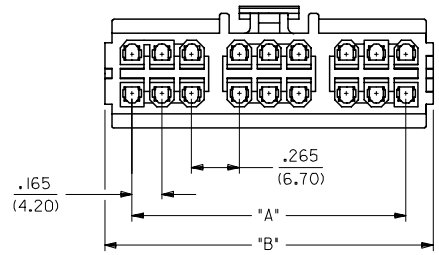

18 CIRCUIT

LEGEND:

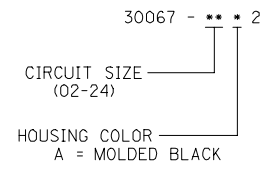

SEE SHEET ONE EC NO: UCP2005-1142 G DRWALS:EMWART 2004/12/16 CHKD:GPOLGAR 2004/12/16 APPR:YMARGULLI 2004/12/20 REV DESCRIPTION	QUALITY SYMBOLS	GENERAL TOLERANCES (UNLESS SPECIFIED)	DIMENSION STYLE IN/MM	SCALE 2:1	DESIGN UNITS INCH	THIRD ANGLE PROJECTION																														
	 	<table border="1"> <thead> <tr> <th></th> <th>mm</th> <th>INCH</th> </tr> </thead> <tbody> <tr> <td>4 PLACES</td> <td>± .010</td> <td>± .0004</td> </tr> <tr> <td>3 PLACES</td> <td>± .012</td> <td>± .0005</td> </tr> <tr> <td>2 PLACES</td> <td>± 0.25</td> <td>± .010</td> </tr> <tr> <td>1 PLACE</td> <td>± 0.36</td> <td>± .014</td> </tr> <tr> <td colspan="3">ANGULAR ±1/2°</td> </tr> </tbody> </table>		mm	INCH	4 PLACES	± .010	± .0004	3 PLACES	± .012	± .0005	2 PLACES	± 0.25	± .010	1 PLACE	± 0.36	± .014	ANGULAR ±1/2°			<table border="1"> <tr> <td>DRAWN BY</td> <td>DATE</td> </tr> <tr> <td>RJF</td> <td>09/23/09</td> </tr> <tr> <td>CHECKED BY</td> <td>DATE</td> </tr> <tr> <td>GEP</td> <td>09/23/09</td> </tr> <tr> <td>APPROVED BY</td> <td>DATE</td> </tr> <tr> <td>RAS</td> <td>09/23-04</td> </tr> </table>	DRAWN BY	DATE	RJF	09/23/09	CHECKED BY	DATE	GEP	09/23/09	APPROVED BY	DATE	RAS	09/23-04	TITLE	MINI-FIT T.P.A. RECEPTACLE HOUSING	
		mm	INCH																																	
	4 PLACES	± .010	± .0004																																	
3 PLACES	± .012	± .0005																																		
2 PLACES	± 0.25	± .010																																		
1 PLACE	± 0.36	± .014																																		
ANGULAR ±1/2°																																				
DRAWN BY	DATE																																			
RJF	09/23/09																																			
CHECKED BY	DATE																																			
GEP	09/23/09																																			
APPROVED BY	DATE																																			
RAS	09/23-04																																			
DRAFT WHERE APPLICABLE MUST REMAIN WITHIN DIMENSIONS			MATERIAL NO. SEE CHART	DOCUMENT NO. SD-30067-*	SHEET NO. 2 OF 2	MOLEX INCORPORATED																														
THIS DRAWING CONTAINS INFORMATION THAT IS PROPRIETARY TO MOLEX INCORPORATED AND SHOULD NOT BE USED WITHOUT WRITTEN PERMISSION																																				