

| MATERIAL NO. LOOSE PIECE | ENG. NO. | STUD SIZE | ±.003 "S" | STOCK THICKNESS |
|-----------------------------|----------|--------------|--------------|--------------------|
| 191930303 | G-375-10 | 10 | .198 | .075 (1.90) |
| 191930305 | G-375-14 | 1/4 | .265 | |
| 191930309 | G-375-56 | 5/16 | .328 | |
| 191930307 | G-375-38 | 3/8 | .390 | |
| 191930311 | G-375-76 | 7/16 | .453 | |

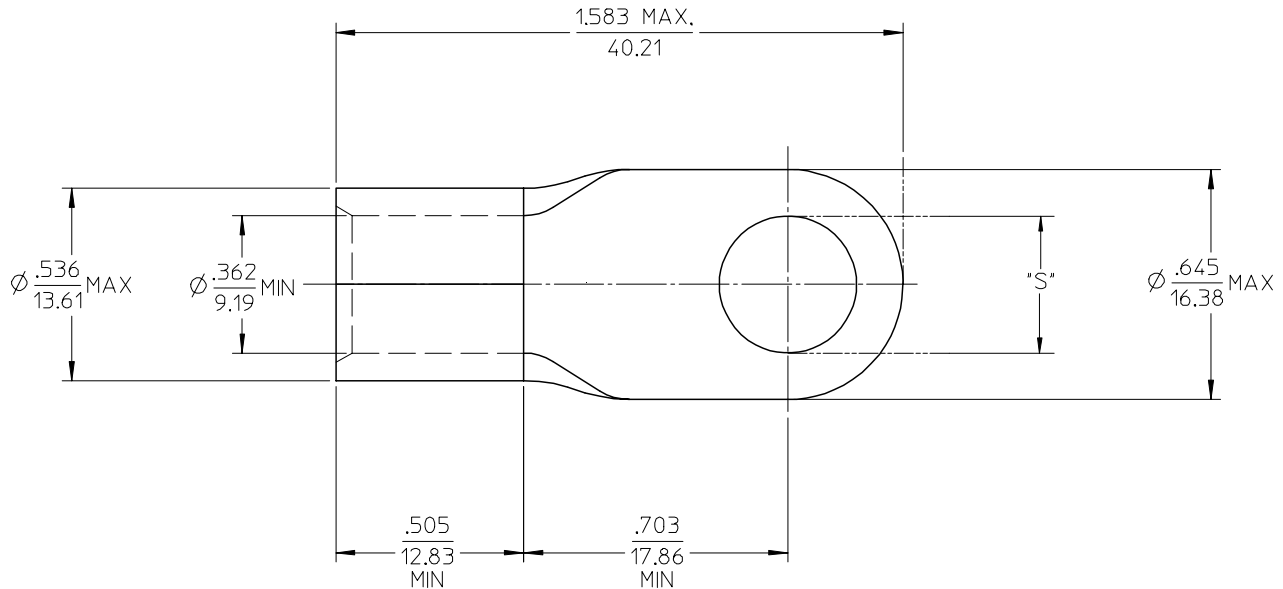

SALES DRAWING

- NOTE(S):
1. MATERIAL: COPPER
 2. PLATING: ELECTROPLATE TIN
 3. ALL DIMENSIONS IN INCHES/(MM).
 4. WIRE SIZE: 2 AWG
35 MM²

| REVISED/UPDATE TO MK STDS EC NO: ETC2003-0315 DRWN:DMYRICK 2003/08/20 CHKD:HEB 2003/08/21 APPR:RDEROSS 2003/08/21 | DESCRIPTION B | QUALITY SYMBOLS | GENERAL TOLERANCES (UNLESS SPECIFIED) | SCALE 2:1 | DESIGN UNITS INCH | THIRD ANGLE PROJECTION | REVISE ON CAD ONLY | | | | | | | | | | | | | | | | |
|---|------------------|------------------|--|------------------|-----------------------------|------------------------------|---------------------|--------|--------|----------|--------|--------|----------|--------|-------|---------|--------|--------|--------------------------|-------|---|--|--|
| | | ▼ = 0 ∇ = 0 | <table border="1"> <thead> <tr> <th></th> <th>mm</th> <th>INCH</th> </tr> </thead> <tbody> <tr> <td>4 PLACES</td> <td>± .---</td> <td>± .---</td> </tr> <tr> <td>3 PLACES</td> <td>± .---</td> <td>± .005</td> </tr> <tr> <td>2 PLACES</td> <td>± 0.13</td> <td>± .01</td> </tr> <tr> <td>1 PLACE</td> <td>± 0.25</td> <td>± .---</td> </tr> </tbody> </table> | | mm | INCH | 4 PLACES | ± .--- | ± .--- | 3 PLACES | ± .--- | ± .005 | 2 PLACES | ± 0.13 | ± .01 | 1 PLACE | ± 0.25 | ± .--- | DIMENSION STYLE IN/MM | TITLE | RING TONGUE TERMINAL VERSAKRIMP 2 AWG | | |
| | | | mm | INCH | | | | | | | | | | | | | | | | | | | |
| | | 4 PLACES | ± .--- | ± .--- | | | | | | | | | | | | | | | | | | | |
| 3 PLACES | ± .--- | ± .005 | | | | | | | | | | | | | | | | | | | | | |
| 2 PLACES | ± 0.13 | ± .01 | | | | | | | | | | | | | | | | | | | | | |
| 1 PLACE | ± 0.25 | ± .--- | | | | | | | | | | | | | | | | | | | | | |
| DRAFT WHERE APPLICABLE MUST REMAIN WITHIN DIMENSIONS | DRAWN BY DLM | DATE 03/07/11 | CHECKED BY HEB | DATE 03/07/11 | MATERIAL NO. (SEE CHART) | DOCUMENT NO. SD-19193-028 | SHEET NO. 1 OF 1 | | | | | | | | | | | | | | | | |

THIS DRAWING CONTAINS INFORMATION THAT IS PROPRIETARY TO MOLEX INCORPORATED AND SHOULD NOT BE USED WITHOUT WRITTEN PERMISSION