

13	12	11	10	9	8	7	6	5	4	3	2	1				
UNPLATED MATERIAL NUMBER	UNPLATED ENG. NUMBER	UNPLATED MAT. NO. ON TAPE	UNPLATED ENG. NO. ON TAPE	PLATED MATERIAL NUMBER	PLATED ENGINEERING NUMBER	PLATED MAT. NO. ON TAPE	PLATED ENG. NO ON TAPE	SEE DETAIL	STUD SIZE	AWG WIRE RANGE	"S"	"L"	"W"	"C"	⊕ "B"	⊕ "T"
192210408	BCL-810	190820012	BCL-810T	192210223	BCL-810-PL	190820011	BCL-810-PLT	A	10/(4.8)	8	.214/(5.45)	1.187/(30.15)	.438/(11.13)	.376/(9.55)	.185/(4.70)	.070/(1.78)
192210409	BCL-814	190820014	BCL-814T	192210224	BCL-814-PL	190820013	BCL-814-PLT	A	1/4/(6.4)	8	.278/(7.06)	1.187/(30.15)	.438/(11.13)	.376/(9.55)	.185/(4.70)	.070/(1.78)
192210562	BCL-814-WP	---	---	192210563	BCL-814-WP-PL	---	---	---	1/4/(6.4)	8	.278/(7.06)	1.313/(33.35)	.594/(15.09)	.376/(9.55)	.185/(4.70)	.070/(1.78)
192210411	BCL-8516	190820017	BCL-8516T	192210225	BCL-8516-PL	---	---	A	5/16/(7.9)	8	.340/(8.63)	1.187/(30.15)	.438/(11.13)	.376/(9.55)	.185/(4.70)	.070/(1.78)
192210482	BCL-8516-WP	---	---	192210483	BCL-8516-WP-PL	190820016	BCL-8516-PLT	A	5/16/(7.9)	8	.340/(8.63)	1.313/(33.35)	.594/(15.09)	.422/(10.72)	.185/(4.70)	.070/(1.78)
192210410	BCL-838-WP	190820015	BCL-838-WPT	192210226	BCL-838-WP-PL	---	---	A	3/8/(9.5)	8	.400/(10.16)	1.313/(33.35)	.594/(15.09)	.422/(10.72)	.185/(4.70)	.070/(1.78)
192210481	BCL-838-XWP	---	---	192210484	BCL-838-XWP-PL	---	---	---	3/8/(9.5)	8	.400/(10.16)	1.313/(33.35)	.766/(19.46)	.394/(10.01)	.185/(4.70)	.070/(1.78)
192210415	BCL-812-XWP	---	---	192210414	BCL-812-XWP-PL	---	---	---	1/2/(14.7)	8	.520/(13.21)	1.469/(37.31)	.766/(19.46)	.394/(10.01)	.185/(4.70)	.070/(1.78)
192210425	BCL-610	---	---	192210424	BCL-610-PL	190820003	BCL-610-PLT	B	10/(4.8)	6	.214/(5.45)	1.281/(32.54)	.438/(11.13)	.345/(8.75)	.232/(5.89)	.075/(1.90)
192210406	BCL-614-WP	190820006	BCL-614T	192210227	BCL-614-WP-PL	190820005	BCL-614-PLT	B	1/4/(6.4)	6	.278/(7.06)	1.406/(35.72)	.594/(15.09)	.352/(8.94)	.232/(5.89)	.080/(2.03)
192210494	BCL-6141	---	---	192210495	BCL-6141-PL	192210498	BCL-6141-PLT	B	1/4/(6.4)	6	.278/(7.06)	1.281/(32.54)	.438/(11.13)	.345/(8.75)	.232/(5.89)	.075/(1.90)
192210407	BCL-6516-WP	---	---	192210228	BCL-6516-WP-PL	190820009	BCL-6516-PLT	B	5/16/(7.9)	6	.340/(8.63)	1.406/(35.72)	.594/(15.09)	.352/(8.94)	.232/(5.89)	.080/(2.03)
192210493	BCL-6561	190820010	BCL-6561T	192210492	BCL-6561-PL	192210499	BCL-6561-PLT	B	5/16/(7.9)	6	.340/(8.63)	1.281/(32.54)	.438/(11.13)	.345/(8.75)	.232/(5.89)	.075/(1.90)
192210384	BCL-638-WP	190820008	BCL-638T	192210229	BCL-638-WP-PL	190820007	BCL-638-PLT	B	3/8/(9.5)	6	.400/(10.16)	1.406/(35.72)	.594/(15.09)	.352/(8.94)	.232/(5.89)	.080/(2.03)
192210569	BCL-638-XWP	---	---	192210568	BCL-638-XWP-PL	---	---	---	3/8/(9.5)	6	.400/(10.16)	1.563/(39.70)	.766/(19.46)	.422/(10.72)	.232/(5.89)	.080/(2.03)
192210417	BCL-612-XWP	---	---	192210416	BCL-612-XWP-PL	190820004	BCL-612-PLT	B	1/2/(14.7)	6	.520/(13.21)	1.563/(39.70)	.766/(19.46)	.352/(8.94)	.232/(5.89)	.080/(2.03)

⊕

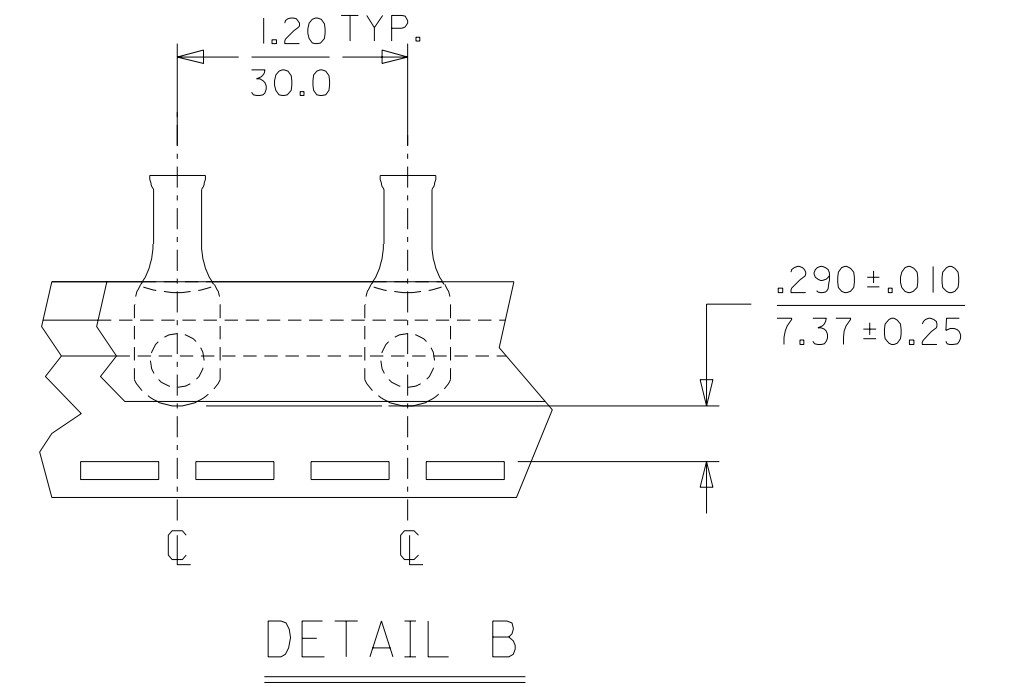
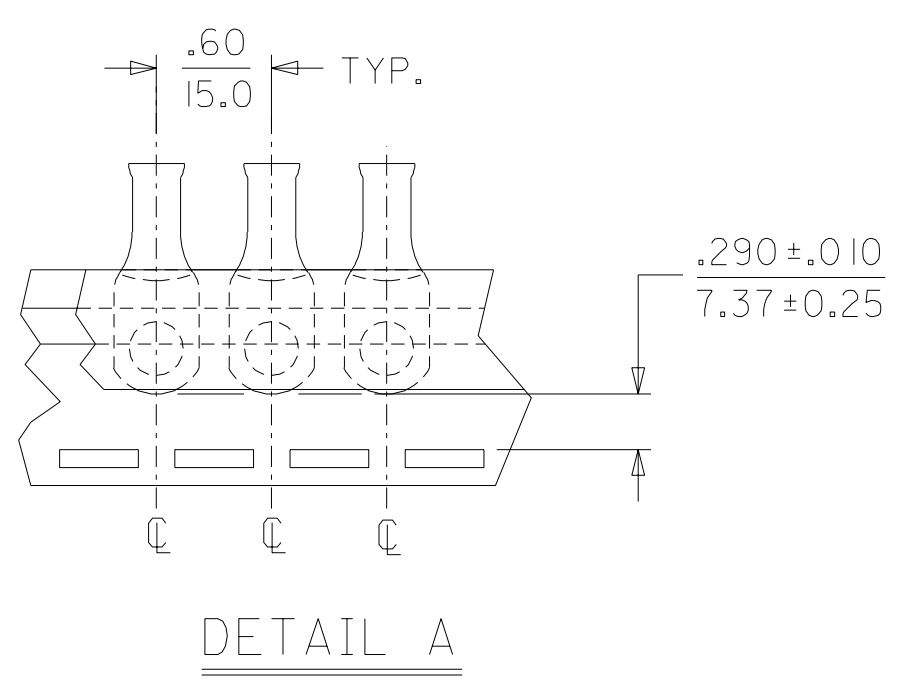
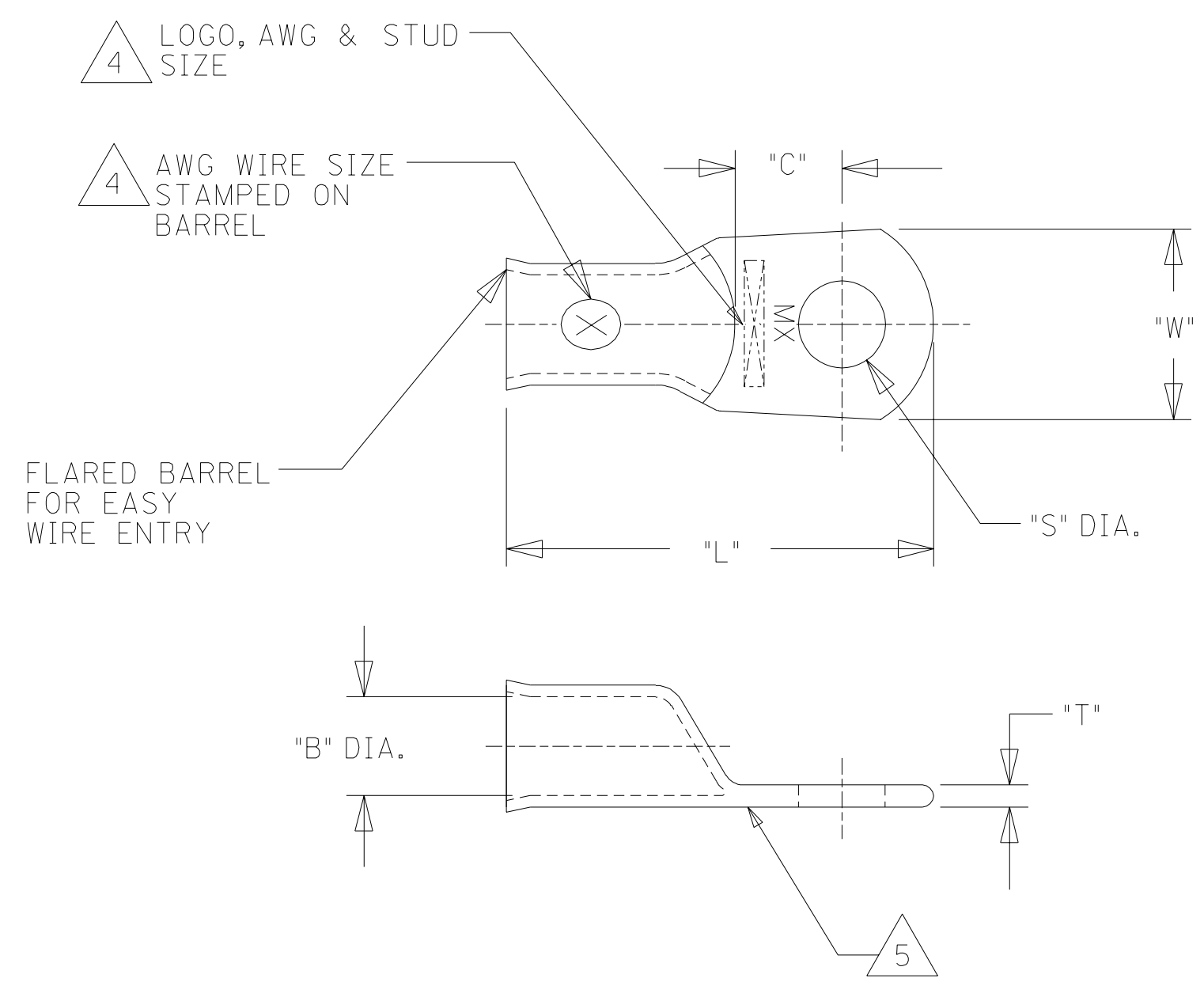

- NOTES:
- FOR INSPECTION SIGHT HOLE, PLEASE CONSULT FACTORY.
  - OTHER STUD SIZES MAY BE AVAILABLE, PLEASE CONSULT FACTORY.
  - MATERIAL: COPPER  
PLATING: TIN
  - MARKINGS CAN BE AT EITHER LOCATION SHOWN.
  - IF TONGUE IS TO BE BENT AT ANY ANGLE, IT MUST BE BENT AROUND A RADIUS ONE HALF THE TONGUE THICKNESS.

SALES DRAWING

ADD P/N'S EC NO. ETC2003-0027 DRWN: BRE 02/08/21 CHK: HEB 02/08/21 APPR: RWD 02/08/21	DESCRIPTION	QUALITY SYMBOLS	GENERAL TOLERANCES: (UNLESS SPECIFIED)	SCALE NO: NE	DESIGN UNITS	THIRD ANGLE PROJECTION	DIMENSIONS:	SHT	REV		
		MAJOR = 0	mm INCH	NO: NE	mm INCH	mm INCH	mm ONLY				
		CRITICAL = 0	4 PLACES ±0. INCH	DRAWN BY & DATE	JM 94/02/14	TITLE: EYELET STYLE COPPER TERMINAL 8 AND 6 AWG LUGS					
			3 PLACES ±0. ±.005	CHECKED BY & DATE	RWD 94/02/14	MOLEX INCORPORATED					
		2 PLACES ±0.13 ±.01	APPROVED BY & DATE	RWD 94/02/14	MATERIAL NO. DRAWING NO. SHEET NO.						
		1 PLACE ±0.25 ±.	CAD FILENAME	SD-19221-001 .DGN	SEE CHART SD-19221-001 1 OF 1						
	REV	ANGULAR: ± 2°	DRAFT WHERE APPLICABLE MUST REMAIN WITHIN DIMENSIONS							THIS DRAWING CONTAINS INFORMATION THAT IS PROPRIETARY TO MOLEX INCORPORATED AND SHOULD NOT BE USED WITHOUT WRITTEN PERMISSION.	SIZE C