

CABLES AND HEATSHRINK NOT SHOWN IN THIS VIEW

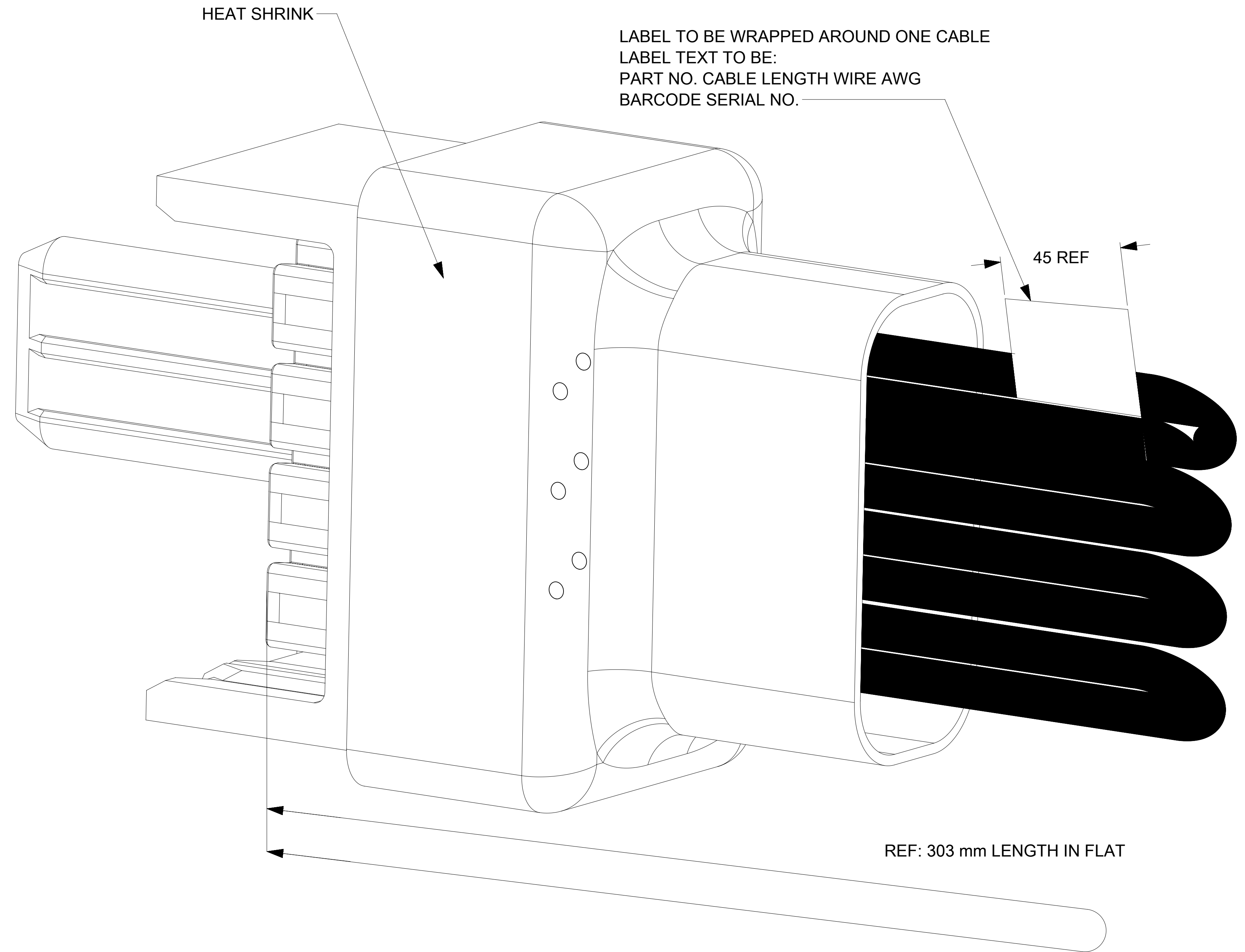
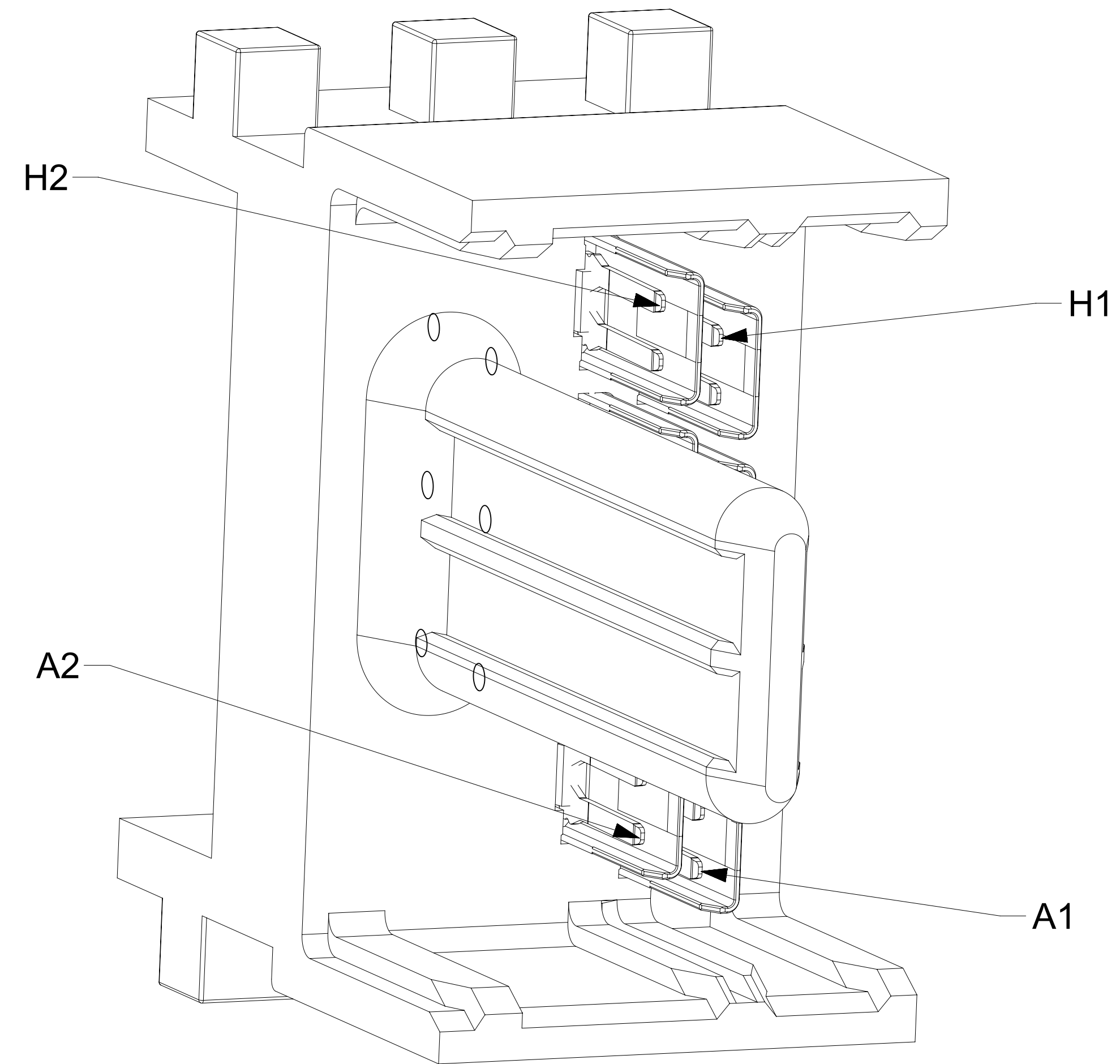

NOTES:

1. CABLE: 30 AWG, 90 OHM TWINAX
2. CONTACT MATERIAL: COPPER ALLOY
3. CONTACT PLATING: GOLD OVER NICKEL
4. WAFER OVERMOLDING MATERIAL: BLACK POLYCARBONATE
5. HOUSING MATERIAL: LIQUID CRYSTAL POLYMER
6. RoHS COMPLIANT, NO EXEMPTIONS
7. IT IS UNDERSTOOD AND AGREED THAT NO GUARANTEE OF COMPLIANCE TO ANY CUSTOMER SPECIFICATION OR MOLEX SPECIFICATION NOT LISTED ON THIS DRAWING IS MADE OR IMPLIED.
8. THE HEATSHRINK SHOWN IS A "REPRESENTATION" OF HOW THE ACTUAL HEAT SHRINK MAY APPEAR ON THE ACTUAL CABLE ASSEMBLIES. THE ACTUAL APPEARANCE WILL VARY.

COLUMN	
2	1
F2	H1
E2	G1
H2	F1
G2	E1
D2	D1
C2	C1
B2	B1
A2	A1

SYMBOLS		THIS DRAWING CONTAINS INFORMATION THAT IS PROPRIETARY TO MOLEX ELECTRONIC TECHNOLOGIES, LLC AND SHOULD NOT BE USED WITHOUT WRITTEN PERMISSION		CURRENT REV DESC: SEE REVISION TABLE	
▽ = 0	mm	SCALE	8:1		
▽ = 0	GENERAL TOLERANCES (UNLESS SPECIFIED)				
▽ = 0	ANGULAR TOL	±	0.5°		
▽ = 0	4 PLACES	±		EC NO: 605347	
▽ = 0	3 PLACES	±		DRWN: MAZAM	2018/07/27
▽ = 0	2 PLACES	±	0.13	CHK'D: DCANTRELL	2018/09/28
▽ = 0	1 PLACE	±	0.25	APPR: SMILLER	2018/10/04
▽ = 0	0 PLACES	±		INITIAL REVISION:	
▽ = 0	DRAFT WHERE APPLICABLE MUST REMAIN WITHIN DIMENSIONS		THIRD ANGLE PROJECTION	DRAWING	SERIES
▽ = 0				D-SIZE	203387
				MATERIAL NUMBER	CUSTOMER
				2033879010	GENERAL MARKET
				DOCUMENT NUMBER	DOC TYPE DOC PART REVISION
				2033879010	PSD 000 B
				SHEET NUMBER	
				1 OF 4	

molex

IMPEL TEST CABLE ASSY, LOOP BACK

PRODUCT CUSTOMER DRAWING

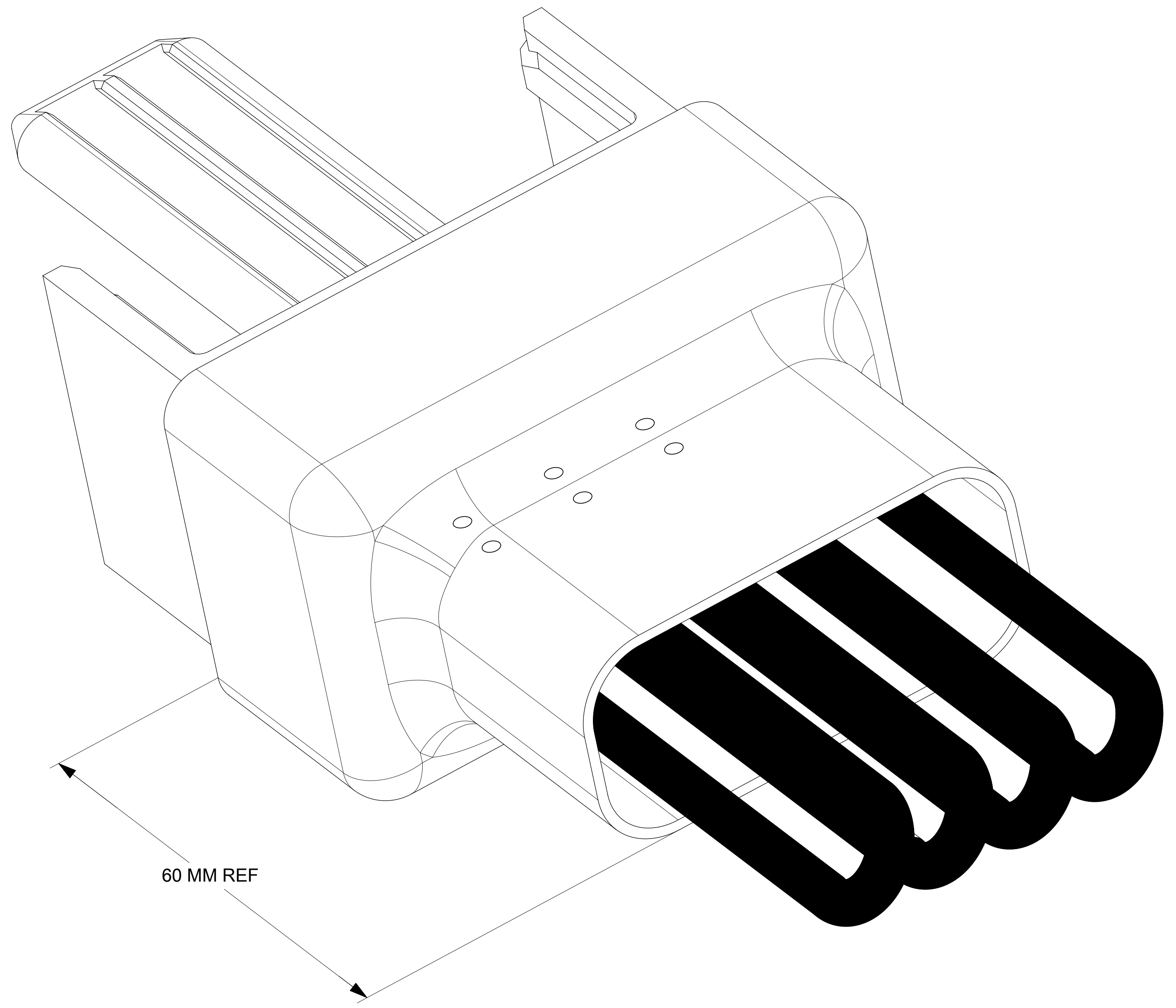
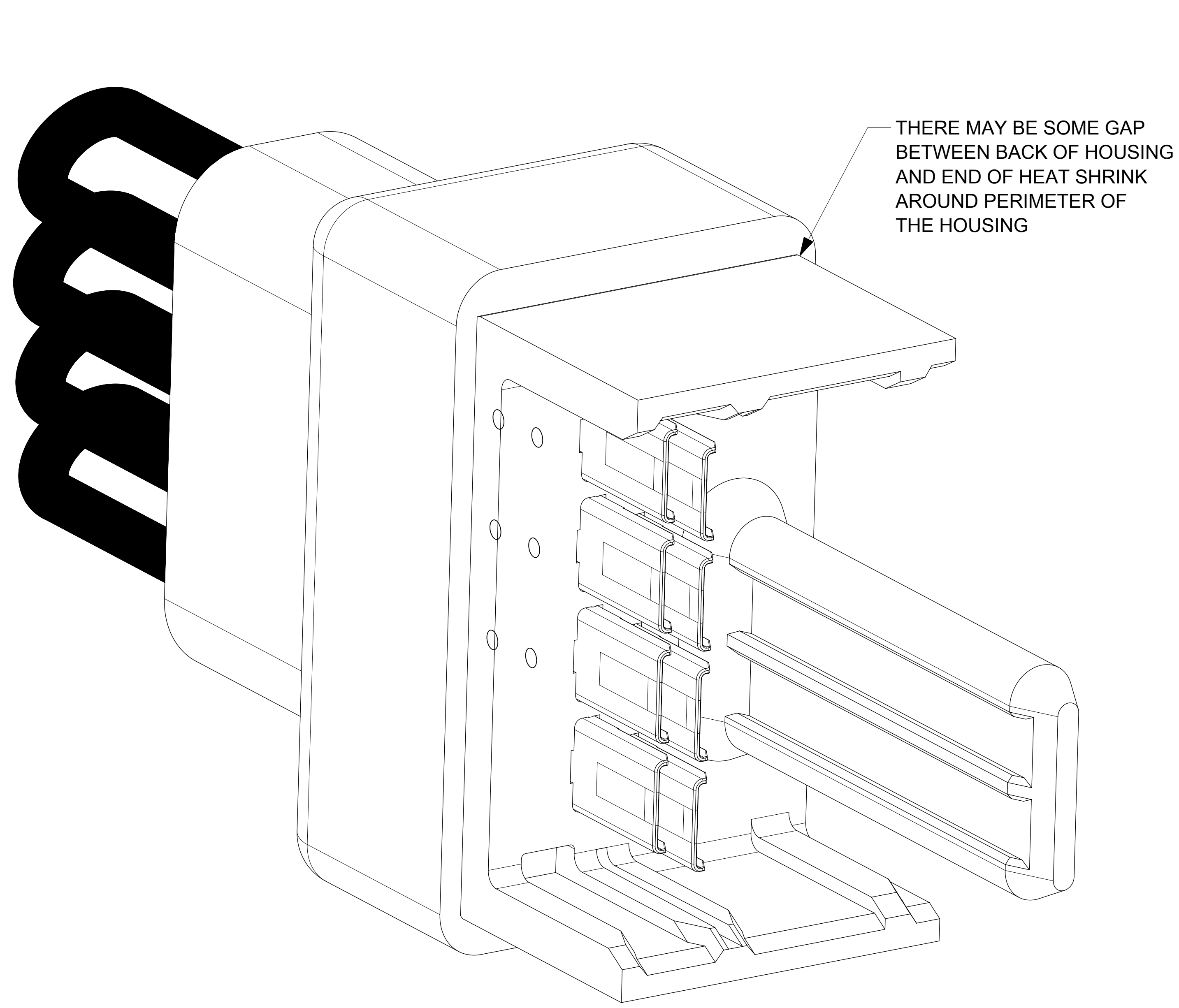

SYMBOLS	THIS DRAWING CONTAINS INFORMATION THAT IS PROPRIETARY TO MOLEX ELECTRONIC TECHNOLOGIES, LLC AND SHOULD NOT BE USED WITHOUT WRITTEN PERMISSION		
	DIMENSION UNITS	SCALE	CURRENT REV DESC: SEE REVISION TABLE
▽ = 0	mm	8:1	molex IMPEL TEST CABLE ASSY, LOOP BACK PRODUCT CUSTOMER DRAWING
▽ = 0	GENERAL TOLERANCES (UNLESS SPECIFIED)		
▽ = 0	ANGULAR TOL ± 0.5°		
▽ = 0	4 PLACES	±	
▽ = 0	3 PLACES	±	
▽ = 0	2 PLACES	± 0.13	EC NO: 605347 DRWN: MAZAM 2018/07/27 CHK'D: DCANTRELL 2018/09/28 APPR: SMILLER 2018/10/04
▽ = 0	1 PLACE	± 0.25	INITIAL REVISION: DRWN: NSRIVATSAHS 2017/10/13 APPR: CHIRSCHY 2018/06/28
▽ = 0	0 PLACES	±	DOCUMENT NUMBER: 2033879010 DOC TYPE: PSD DOC PART: 000 REVISION: B
☒ = 0	DRAFT WHERE APPLICABLE MUST REMAIN WITHIN DIMENSIONS	THIRD ANGLE PROJECTION	DRAWING: D-SIZE SERIES: 203387 MATERIAL NUMBER: 2033879010 CUSTOMER: GENERAL MARKET SHEET NUMBER: 2 OF 4

LABEL DETAILS



YYDDLXXXX = SERIAL NO.:

YY = THE LAST TWO DIGITS OF THE YEAR

DDD = THE DAY OF THE YEAR

L = LOCATION:

1 = USA

2 = MEXICO

3 = CHINA

4 = PHILLIPINES

XXXX = SERIES No. (0000~9999)

NOTES:

1. LABEL REQUIREMENT - ARIAL UNICODE MS FONT. FONT HEIGHT AROUND 2MM. GAP BETWEEN TEXT AND BARCODE 1.5MM MAX. BARCODE HEIGHT AROUND 6MM. BARCODE 128 B.

THIS DRAWING CONTAINS INFORMATION THAT IS PROPRIETARY TO MOLEX ELECTRONIC TECHNOLOGIES, LLC AND SHOULD NOT BE USED WITHOUT WRITTEN PERMISSION																	
SYMBOLS	DIMENSION UNITS	SCALE	CURRENT REV DESC: SEE REVISION TABLE														
▽ = 0	mm	8:1	<div style="font-size: 2em; font-weight: bold; margin-bottom: 10px;">molex</div> <p>IMPEL TEST CABLE ASSY, LOOP BACK</p> <p>PRODUCT CUSTOMER DRAWING</p> <table border="1" style="width: 100%; border-collapse: collapse;"> <tr> <td>DOCUMENT NUMBER</td> <td>DOC TYPE</td> <td>DOC PART</td> <td>REVISION</td> </tr> <tr> <td style="font-size: 1.2em; font-weight: bold;">2033879010</td> <td>PSD</td> <td>000</td> <td>B</td> </tr> </table>							DOCUMENT NUMBER	DOC TYPE	DOC PART	REVISION	2033879010	PSD	000	B
DOCUMENT NUMBER	DOC TYPE	DOC PART								REVISION							
2033879010	PSD	000								B							
▽ = 0	GENERAL TOLERANCES (UNLESS SPECIFIED)																
▽ = 0	ANGULAR TOL	± 0.5°															
▽ = 0	4 PLACES	±															
▽ = 0	3 PLACES	±															
▽ = 0	2 PLACES	± 0.13															
▽ = 0	1 PLACE	± 0.25															
▽ = 0	0 PLACES	±															
■ = 0	DRAFT WHERE APPLICABLE MUST REMAIN WITHIN DIMENSIONS	THIRD ANGLE PROJECTION	DRAWING	SERIES	MATERIAL NUMBER	CUSTOMER	SHEET NUMBER										
▽ = 0			D-SIZE	203387	2033879010	GENERAL MARKET	3 OF 4										

