

10 9 8 7 6 5 4 3 2 1

F
E
D
C
B
A

F
E
D
C
B
A

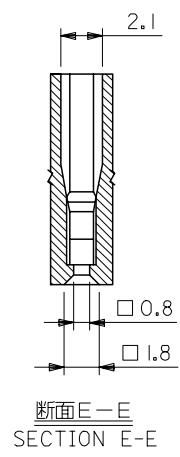
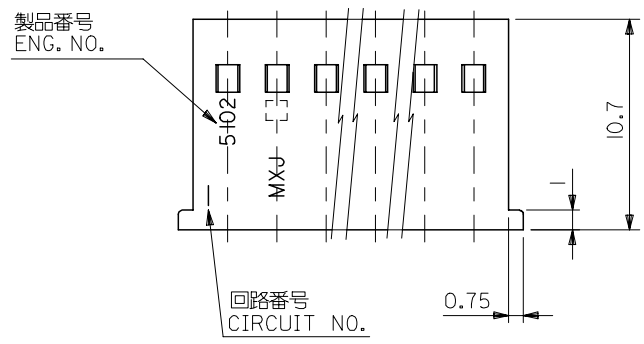
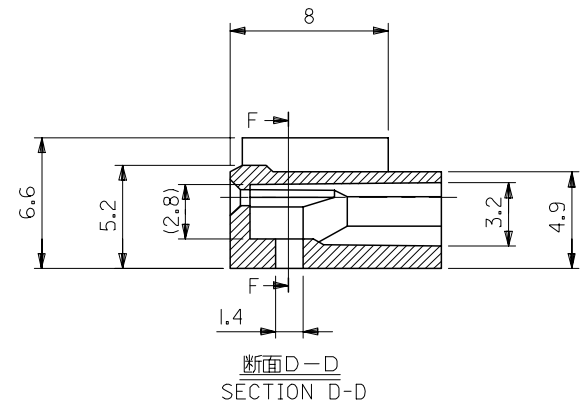
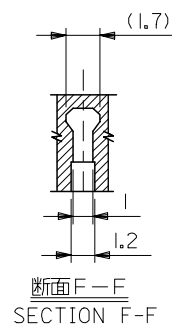
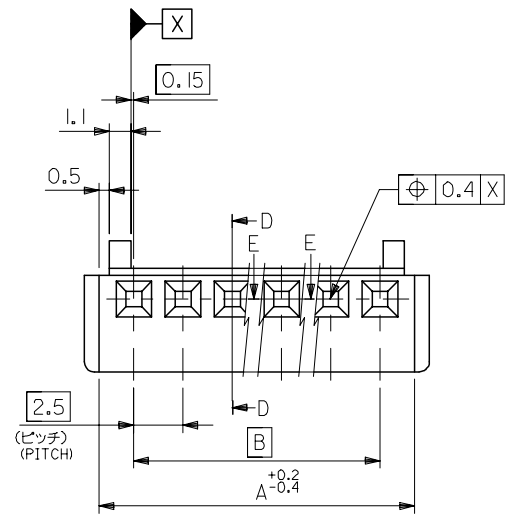

47.5	51	22-01-1204	5102-20	20
45	48.5	▲ -1194	▲ -19	19
42.5	46	-1184	-18	18
40	43.5	-1174	-17	17
37.5	41	-1164	-16	16
35	38.5	-1154	-15	15
32.5	36	-1144	-14	14
30	33.5	-1134	-13	13
27.5	31	-1124	-12	12
25	28.5	-1114	-11	11
22.5	26	-1104	-10	10
20	23.5	-1094	-09	9
17.5	21	-1084	-08	8
15	18.5	-1074	-07	7
12.5	16	-1064	-06	6
10	13.5	-1054	-05	5
7.5	11	-1044	-04	4
5	8.5	▼ -1034	▼ -03	3
2.5	6	22-01-1024	5102-02	2
B	A	EDP. NO.	ENG. NO.	NO. OF EXTS.

注記
NOTE
使用ターミナル: ENG. NO. 5103*
APPLICABLE TERMINAL: ENG. NO. 5103*

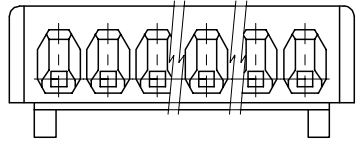

材料
MATERIAL
ナイロン66, UL94V-0
NYLON66, UL94V-0

REVISED EC NO: J2006-3417 DRW: KSAIT001 2006/07/31 CHK: M.TANAKA 2006/08/04 APPR: NUKITA 2006/08/07	GENERAL TOLERANCES (UNLESS SPECIFIED)		DIMENSION STYLE MM ONLY	SCALE 4:1	DESIGN UNITS METRIC	THIRD ANGLE PROJECTION	
	10 UNDER	±0.2	DRAWN BY H. IJIMA	DATE 1996/07/05	TITLE MINI SPOX HSG		
	10 OVER 30 UNDER	±0.25	CHECKED BY M. FUKUSHIMA	DATE 1996/07/05	APPROVED BY M. ENOMOTO		
	30 OVER	±0.3	DATE 1996/07/05		MOLEX INCORPORATED		
	ANGULAR	±3 °	MATERIAL NO.		DOCUMENT NO. SD-5102-001	SHEET NO. 1 OF 1	
DRAFT WHERE APPLICABLE MUST REMAIN WITHIN DIMENSIONS		SIZE A3		THIS DRAWING CONTAINS INFORMATION THAT IS PROPRIETARY TO MOLEX INCORPORATED AND SHOULD NOT BE USED WITHOUT WRITTEN PERMISSION			