

DWG. NO. SD-505 I-N

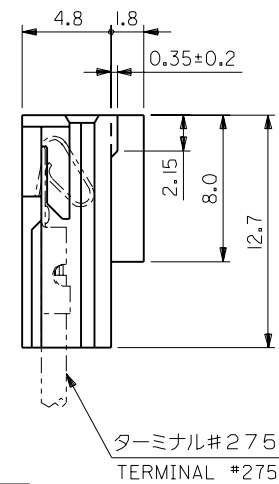
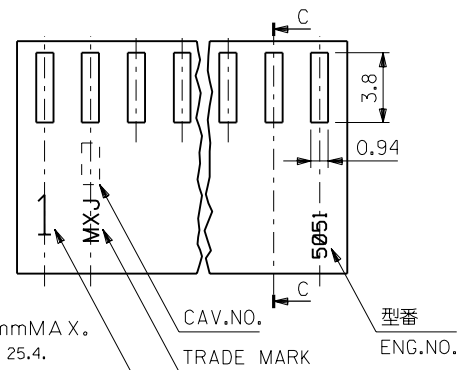
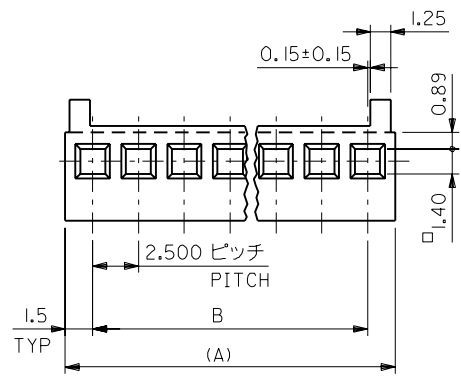

注)
NOTE.

- そりは長さ25.4mmに対して0.2mmMAX. CAMBER MUST BE WITHIN 0.2 MAX. PER 25.4.
- () 寸法は参考値
DIMENSION SHOWN IN () ARE REFERENCE.
- サーキットNO. 1のみ表示 但し2極の場合はMX-Jマーク側が1となる
WHEN 2 CIRCUITS HOUSING TRADE MARK SIDE IN NO.1 CIRCUIT.

MT'L. NYLON 66(94V-0)

5051-20	22-01-1202	20	47.50±0.30	50.50
↑ -19	↑ -1192	19	45.00±0.25	48.00
↑ -18	↑ -1182	18	42.50±0.25	45.50
↑ -17	↑ -1172	17	40.00±0.25	43.00
↑ -16	↑ -1162	16	37.50±0.25	40.50
↑ -15	↑ -1152	15	35.00±0.20	38.00
↑ -14	↑ -1142	14	32.50±0.20	35.50
↑ -13	↑ -1132	13	30.00±0.20	33.00
↑ -12	↑ -1122	12	27.50±0.20	30.50
↑ -11	↑ -1112	11	25.00±0.15	28.00
↑ -10	↑ -1102	10	22.50±0.15	25.50
↑ -09	↑ -1092	9	20.00±0.15	23.00
↑ -08	↑ -1082	8	17.50±0.15	20.50
↑ -07	↑ -1072	7	15.00±0.15	18.00
↑ -06	↑ -1062	6	12.50±0.10	15.50
↑ -05	↑ -1052	5	10.00±0.10	13.00
↑ -04	↑ -1042	4	7.50±0.10	10.50
↑ -03	↑ -1032	3	5.00±0.10	8.00
↓ 5051-02	↓ 22-01-1022	2	2.50±0.08	5.50
ENG. NO.	PART NO.	極数 N	B	(A)

DO NOT SCALE DRAWING

EC NO. DRWN: CHK: APPR:	EC NO. DRWN: CHK: APPR:	EC NO. DRWN: CHK: APPR:	EC NO. DRWN: CHK: APPR:	REDRAWN EC NO. JC2000-0629 DRWN: K.KOHAMA 000/3/28 CHK: T.YAMAGUCHI 000/3/30 APPR: M.FUKUSHIMA 000/3/30	MATERIAL 材料 表参照 SEE TABLE	GENERAL TOLERANCES: (UNLESS SPECIFIED) 一般公差	SCALE 4:1	DESIGN UNITS <input checked="" type="checkbox"/> mm <input type="checkbox"/> INCH	THIRD ANGLE PROJECTION <input type="checkbox"/> mm <input type="checkbox"/> INCH <input checked="" type="checkbox"/> mm ONLY	REVISIONS SHT REV				
					FINISH 仕上げ //	10 UNDER 未満 +0.25 ±0.2	DRAWN BY & DATE K.KOHAMA 000/3/28	TITLE: 2.50/(.098) CENTERS KK. POLZG HSG.	MATERIAL NO. 5051-**	DRAWING NO. SD-5051-N	SHEET NO. 1			
				WIRE RANGE 適用線径範囲 //	10 OVER 以上 +0.3 ±0.25	30 UNDER 未満 +0.35 ±0.3	CHECKED BY & DATE T.YAMAGUCHI 007/3/30					MATERIAL NO. 5051-**	DRAWING NO. SD-5051-N	SHEET NO. 1
				INS. RANGE 被覆外径 //	30 OVER 以上 +0.35 ±0.3	ANGLE 角度 +3°	CAD FILENAME S5051.S01							