

注) NOTE.

1. 材料 MATERIAL
 ピン : 0.635x14.2 黄銅、銅下地錫メッキ
 PIN: 0.635x14.2 BRASS TIN OVER COPPER PLATING.
 ウェハー : ナイロン66, UL 94V-0
 WAFER: NYLON66, UL94V-0
2. 6極以上に適用
 TO BE APPLIED FOR 6 CKT. AND MORE THEN 6 CKT.
3. 5極以下はロック部スリットなし
 NO SLIT IS PROVIDED FOR 5 CKT. AND LESS THAN 5 CKT.

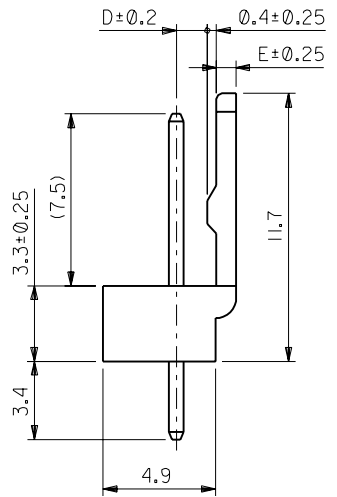
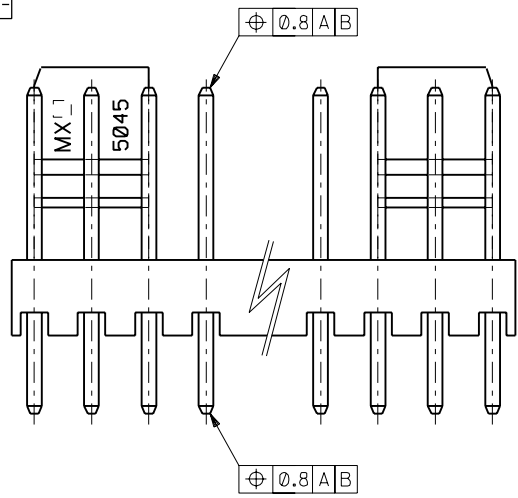

1.35	0.85	47.5 ^{+0.3} _{-0.45}	47.5	22-04-1201	5045-20A	20
↑	↑	45 ^{+0.3} _{-0.45}	45	↑ -1191	↑ -19A	19
		42.5 ^{+0.3} _{-0.45}	42.5	↑ -1181	↑ -18A	18
		40 ^{+0.3} _{-0.45}	40	↑ -1171	↑ -17A	17
		37.5 ^{+0.3} _{-0.45}	37.5	↑ -1161	↑ -16A	16
		35 ^{+0.3} _{-0.45}	35	↑ -1151	↑ -15A	15
		32.5 ^{+0.3} _{-0.45}	32.5	↑ -1141	↑ -14A	14
		30 ^{+0.3} _{-0.45}	30	↑ -1131	↑ -13A	13
		27.5 ^{+0.3} _{-0.45}	27.5	↑ -1121	↑ -12A	12
		25 ^{+0.3} _{-0.45}	25	↑ -1111	↑ -11A	11
		22.5 ^{+0.3} _{-0.45}	22.5	↑ -1101	↑ -10A	10
		20 ^{+0.3} _{-0.45}	20	↑ -1091	↑ -09A	9
		17.5 ^{+0.3} _{-0.45}	17.5	↑ -1081	↑ -08A	8
		15 ^{+0.3} _{-0.45}	15	↑ -1071	↑ -07A	7
		12.5 ^{+0.3} _{-0.45}	12.5	↑ -1061	↑ -06A	6
		10 ^{+0.3} _{-0.45}	10	↑ -1051	↑ -05A	5
1.35	0.85	7.5 ^{+0.3} _{-0.45}	7.5	↑ -1041	↑ -04A	4
↓	↓	5 ^{+0.3} _{-0.45}	5	↓ -1031	↓ -03A	3
1.2	1	2.5 ^{+0.3} _{-0.45}	2.5	22-04-1021	5045-02A	2
D	E	C	B	EDP.NO.	ENG.NO.	極数 CKT.

1. 材料 2. 6極以上に適用 3. 5極以下はロック部スリットなし	公差非累積 NON-ACCUMULATIVE 基板取付穴推奨寸法 RECOMMENDED P.C.BOARD HOLE DIM.	注) NOTE. 1. 材料 MATERIAL ピン : 0.635x14.2 黄銅、銅下地錫メッキ PIN: 0.635x14.2 BRASS TIN OVER COPPER PLATING. ウェハー : ナイロン66, UL 94V-0 WAFER: NYLON66, UL94V-0 2. 6極以上に適用 TO BE APPLIED FOR 6 CKT. AND MORE THEN 6 CKT. 3. 5極以下はロック部スリットなし NO SLIT IS PROVIDED FOR 5 CKT. AND LESS THAN 5 CKT.	1.35 0.85 47.5 ^{+0.3} _{-0.45} 47.5 22-04-1201 5045-20A 20 ... (rest of table) ...	材料 材料 注記参照 SEE NOTES	GENERAL TOLERANCES: (UNLESS SPECIFIED) 一般公差	SCALE 5:1	DESIGN UNITS <input checked="" type="checkbox"/> mm <input type="checkbox"/> INCH	DIMENSIONS: <input type="checkbox"/> mm <input type="checkbox"/> INCH <input checked="" type="checkbox"/> mm ONLY	SHT 1	REV 1
				REDRAWN redrawn	FINISH 仕上り	WIRE RANGE 通線線径	ANGLE 角度	DRAWN BY & DATE K.KOHAMA 00/3/28	CHECKED BY & DATE T.YAMAGUCHI 00/3/30	APPROVED BY & DATE M.FUKUSHIMA 00/3/30