

Distributed by:

JAMECO[®]
ELECTRONICS

www.Jameco.com ♦ 1-800-831-4242

The content and copyrights of the attached
material are the property of its owner.

Jameco Part Number 795827

FEATURES AND SPECIFICATIONS

Features and Benefits

- Sizes 2 to 15 circuits
- 0.70mm (.027") round pins
- Polarized
- Friction lock

Reference Information

Packaging: Bag
 UL File No.: E29179
 CSA File No.: LR19980
 Mates With: [5264-N](#) and [42219](#)
 Designed In: Millimeters

Electrical

Voltage: 250V
 Current:

AWG	22	24	26	28
Amperes	3.0	2.5	2.0	1.5

Contact Resistance: 20mΩ max.
 Dielectric Withstanding Voltage: 1000V AC/1 min.
 Insulation Resistance: 1000 MΩ min.

Physical

Housing: 6/6 nylon, UL 94V-0
 Contact: Brass
 Plating: Tin
 Operating Temperature: -40 to +105°C

molex® 2.50mm (.098") Pitch SPOX™ Wire-to-Board Header

5268-NA Right Angle Fully Shrouded

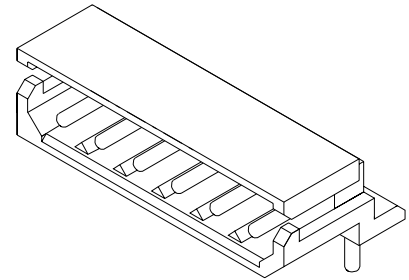

B
 2.00 to 2.50mm (.079 to .098") Pitch

CATALOG DRAWING (FOR REFERENCE ONLY)

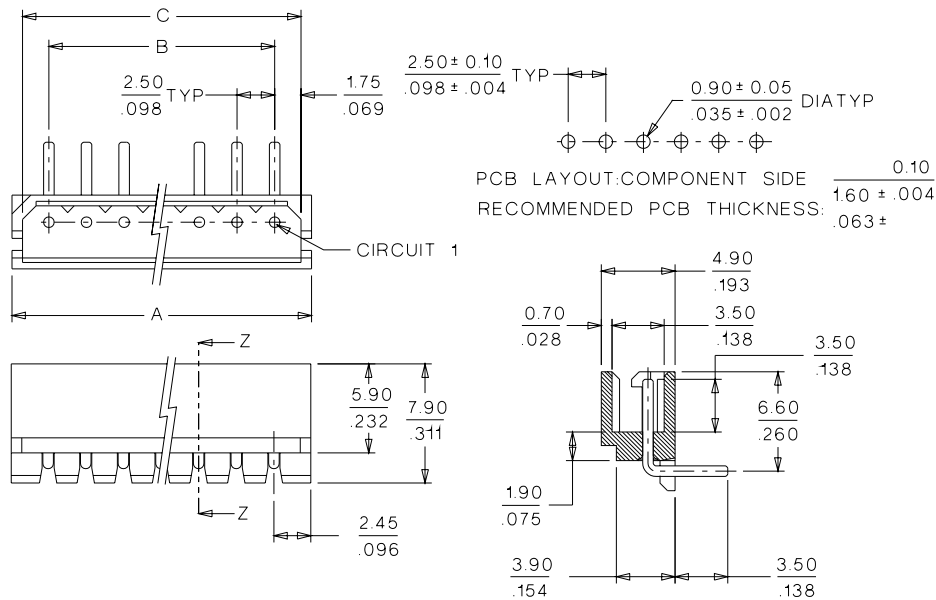

ORDERING INFORMATION AND DIMENSIONS

Circuits	Order No.	Dimension		
		A	B	C
2	22-05-7025	7.40 (.291)	2.50 (.098)	6.00 (.236)
3	22-05-7035	9.90 (.390)	5.00 (.197)	8.50 (.335)
4	22-05-7045	12.40 (.488)	7.50 (.295)	11.00 (.433)
5	22-05-7055	14.90 (.587)	10.00 (.394)	13.50 (.531)
6	22-05-7065	17.40 (.685)	12.50 (.492)	16.00 (.630)
7	22-05-7075	19.90 (.783)	15.00 (.591)	18.50 (.728)
8	22-05-7085	22.40 (.882)	17.50 (.689)	21.00 (.827)
9	22-05-7095	24.90 (.980)	20.00 (.787)	23.50 (.925)
10	22-05-7105	27.40 (1.079)	22.50 (.886)	26.00 (1.024)
11	22-05-7115	29.90 (1.117)	25.00 (.984)	28.50 (1.122)
12	22-05-7125	32.40 (1.276)	27.50 (1.083)	31.00 (1.220)
13	22-05-7135	34.90 (1.374)	30.00 (1.181)	33.50 (1.319)
14	22-05-7145	37.40 (1.472)	32.50 (1.280)	36.00 (1.417)
15	22-05-7155	39.90 (1.571)	35.00 (1.378)	38.50 (1.516)



PRODUCT SPECIFICATION



LANGUAGE

JAPANESE
ENGLISH

【 4. 性 能 PERFORMANCE 】

4 - 1. 電 氣 的 性 能 Electrical Performance

項 目 Item	条 件 Test Condition	規 格 Requirement
4-1-1 接 触 抵 抗 Contact Resistance	コネクタを嵌合させ、開放電圧 20mV 以下、 短絡電流 10mA にて測定する。 (JIS C5402 5.4) Mate connectors, measure by dry circuit, 20mV MAX., 10mA. (JIS C5402 5.4)	20 milliohms MAX.
4-1-2 絶 縁 抵 抗 Insulation Resistance	コネクタを嵌合させ、隣接するターミナル間 及びターミナル、アース間に、DC 500V を 印加し測定する。 (JIS C5402 5.2/MIL-STD-202 試験法 302) Mate connectors, apply 500V DC between adjacent terminal or ground. (JIS C5402 5.2/MIL-STD-202 Method 302)	1000 Megohms MIN.
4-1-3 耐 電 圧 Dielectric Strength	コネクタを嵌合させ、隣接するターミナル間 及びターミナル、アース間に、AC(rms) 1000V (実効値) を 1分間 印加する。 (JIS C5402 5.1/MIL-STD-202 試験法 301) Mate connectors, apply 1000V AC(rms) for 1 minute between adjacent terminal or ground.(JIS C5402 5.1/MIL-STD-202 Method 301)	異常なきこと No Breakdown
4-1-4 圧着部接触抵抗 Contact Resistance on Crimped Portion	ターミナルに適合電線を圧着し、開放電圧 20mV 以下、短絡電流 10mA にて測定する。 Crimp the applicable wire on to the terminal, measure by dry circuit, 20mV MAX., 10mA.	5 milliohms MAX.

D	REVISE ON PC ONLY	TITLE: 2.5 mm PITCH LOW PROFILE CONNECTOR 製品仕様書	
	REVISED		
	DESCRIPTION		
REV.	DESCRIPTION	THIS DOCUMENT CONTAINS INFORMATION THAT IS PROPRIETARY TO INC. AND MUST NOT BE USED WITHOUT WRITTEN PERMISSION	
DOCUMENT NUMBER PS-5264-001		FILENAME PS000033.LWP	SHEET 2 OF 10
ES-4000-3996 REV. A SHEET 4 95/MAR/10 EC U5-0926 DCBRD03.LWP		W to B 1 EN-37-1(019)	



PRODUCT SPECIFICATION



LANGUAGE

JAPANESE
ENGLISH

4 - 2. 機械的性能 Mechanical Performance

項 目 Item		条 件 Test Condition		規 格 Requirement
4-2-1	挿入力及び抜去力 Insertion and Withdrawal Force	毎分 25±3mm の速さで挿入、抜去を行なう。 Insert and withdraw connectors at the speed rate of 25±3mm/minute.		第 6 項 参 照 Refer to paragraph 6.
4-2-2	圧着部引張り強度 Crimping Pull Out Force	圧着されたターミナルを治具に固定し、電線を軸方向に毎分 25±3mm の速さで引張る。 (JIS C5402 6.8) Fix the crimped terminal, apply axial pull out force on the wire at the speed rate of 25±3mm/minute. (JIS C5402 6.8)	AWG.#22	39.2 N { 4.0 kgf } MIN.
			AWG.#24	29.4 N { 3.0 kgf } MIN.
			AWG.#26	19.6 N { 2.0 kgf } MIN.
			AWG.#28	9.8 N { 1.0 kgf } MIN.
4-2-3	ターミナル挿入力 Terminal Insertion Force	圧着されたターミナルをハウジングに挿入する。 Insert the crimped terminal into the housing.		14.7 N { 1.5 kgf } MAX.
4-2-4	ターミナル保持力 Terminal/Housing Retention Force	圧着されたターミナルをハウジングに装着し、電線を軸方向に毎分 25±3mm の速さで引張る。 Apply axial pull out force at the speed rate of 25±3 mm/minute on the terminal assembled in the housing.		14.7 N { 1.5 kgf } MIN.

D	REVISE ON PC ONLY		TITLE: 2.5 mm PITCH LOW PROFILE CONNECTOR 製品仕様書
	REVISED		
	REV.	DESCRIPTION	
DOCUMENT NUMBER PS-5264-001			THIS DOCUMENT CONTAINS INFORMATION THAT IS PROPRIETARY TO INC. AND MUST NOT BE USED WITHOUT WRITTEN PERMISSION
DOCUMENT NUMBER PS-5264-001		FILENAME PS000033.LWP	SHEET 3 OF 10
ES-4000-3996 REV. A SHEET 4 95/MAR/10 EC U5-0926 DCBRD03.LWP			W to B 1 EN-37-1(019)



PRODUCT SPECIFICATION



LANGUAGE

JAPANESE
ENGLISH

項目 Item	条件 Test Condition	規格 Requirement
4-2-5 ピン保持力 Pin Retention Force	毎分 25±3mm の速さでピンを軸方向に押す。 Apply axial push force at the speed rate of 25±3mm /minute.	9.8 N { 1.0 kgf } MIN.

4 - 3. その他 Environmental Performance and Others

項目 Item	条件 Test Condition	規格 Requirement
4-3-1 繰返し挿抜 Repeated Insertion/ Withdrawal	1分間 10回 以下の速さで挿入、抜去を 30回 繰返す。 When mated up to 30 cycles repeatedly by the rate of 10 cycles per minute.	接触抵抗 Contact Resistance 40 milliohms MAX.
4-3-2 温度上昇 Temperature Rise	コネクタを嵌合させ、最大許容電流を通电し、コネクタの温度上昇分を測定する。(UL 498) Carrying rated current load. (UL 498)	温度上昇 Temperature rise 30 °C MAX.
4-3-3 耐振動性 Vibration	DC 1mA 通电状態にて、嵌合軸を含む互いに垂直な 3方向 に掃引割合 10~55~10 Hz/分 全振幅 1.5mm の振動を各 2時間 加える。 (MIL-STD-202 試験法 201) Amplitude: 1.5mm P-P Sweep time: 10~55~10 Hz in 1 minute Duration: 2 hours in each X.Y.Z. axes (MIL-STD-202 Method 201)	外観 Appearance 異状なきこと No Damage
		接触抵抗 Contact Resistance 40 milliohms MAX.
		瞬断 Discontinuity 1 microsecond MAX.

REVISE ON PC ONLY		TITLE: 2.5 mm PITCH LOW PROFILE CONNECTOR 製品仕様書
D	REVISED	
REV.	DESCRIPTION	
THIS DOCUMENT CONTAINS INFORMATION THAT IS PROPRIETARY TO INC. AND MUST NOT BE USED WITHOUT WRITTEN PERMISSION		
DOCUMENT NUMBER PS-5264-001	FILENAME PS000033.LWP	SHEET 4 OF 10
ES-4000-3996 REV. A SHEET 4 95/MAR/10 EC U5-0926 DCBRD03.LWP		W to B 1 EN-37-1(019)



PRODUCT SPECIFICATION



LANGUAGE

JAPANESE
ENGLISH

項目 Item		条件 Test Condition	規格 Requirement	
4-3-4	耐衝撃性 Shock	DC 1mA 通電状態にて、嵌合軸を含む互いに垂直な 6方向に 490m/s ² {50G} の衝撃を各 3回 加える。 (JIS C0041/MIL-STD-202 試験法213) 490m/s ² {50G}, 3 strokes in each X.Y.Z. axes. (JIS C0041MIL-STD-202 Method 213)	外観 Appearance	異状なきこと No Damage
			接触抵抗 Contact Resistance	40 milliohms MAX.
			瞬断 Dis-continuity	1 microsecond MAX.
4-3-5	耐熱性 Heat Resistance	コネクタを嵌合させ、105±2 °C の雰囲気中に 96時間 放置後取り出し、1~2 時間 室温に放置する。 (JIS C0021/MIL-STD-202 試験法108) 105±2 °C, 96 hours (JIS C0021/MIL-STD-202 Method 108)	外観 Appearance	異状なきこと No Damage
			接触抵抗 Contact Resistance	40 milliohms MAX.
4-3-6	耐寒性 Cold Resistance	コネクタを嵌合させ、-40±3 °C の雰囲気中に 96時間 放置後取り出し、1~2時間 室温に放置する。 (JIS C0020) -40±3 °C, 96 hours (JIS C0020)	外観 Appearance	異状なきこと No Damage
			接触抵抗 Contact Resistance	40 milliohms MAX.

REVISE ON PC ONLY		TITLE: 2.5 mm PITCH LOW PROFILE CONNECTOR 製品仕様書	THIS DOCUMENT CONTAINS INFORMATION THAT IS PROPRIETARY TO INC. AND MUST NOT BE USED WITHOUT WRITTEN PERMISSION
D	REVISED		
REV.	DESCRIPTION		
DOCUMENT NUMBER PS-5264-001		FILENAME PS000033.LWP	SHEET 5 OF 10
ES-4000-3996 REV. A SHEET 4 95/MAR/10 EC U5-0926 DCBRD03.LWP			W to B 1 EN-37-1(019)



PRODUCT SPECIFICATION



LANGUAGE

JAPANESE
ENGLISH

項目 Item		条件 Test Condition	規格 Requirement	
4-3-7	耐湿性 Humidity	コネクタを嵌合させ、60±2 °C、 相対湿度 90 ~ 95% の雰囲気中に 96時間 放置後取り出し、 1 ~ 2時間 室温に放置する。 (JIS C0022/MIL-STD-202 試験法103) Temperature: 60±2 °C Relative Humidity: 90 ~ 95% Duration: 96 hours (JIS C0022/MIL-STD-202 Method 103)	外観 Appearance	異状なきこと No Damage
			接触抵抗 Contact Resistance	40 milliohms MAX.
			耐電圧 Dielectric Strength	4-1-3項満足のこと Must meet 4-1-3
			絶縁抵抗 Insulation Resistance	100 Megohms MIN.
4-3-8	温度サイクル Temperature Cycling	コネクタを嵌合させ、-55 °C に 30分、+105 °C に 30分 これを 1サイクルとし、5サイクル 繰返す。 但し、温度移行時間は 5分 以内とする。 試験後 1 ~ 2時間 室温に放置する。 (JIS C0025) 5 cycles of: a) - 55 °C 30 minutes b) +105 °C 30 minutes (JIS C0025)	外観 Appearance	異状なきこと No Damage
			接触抵抗 Contact Resistance	40 milliohms MAX.

REVISE ON PC ONLY		TITLE: 2.5 mm PITCH LOW PROFILE CONNECTOR 製品仕様書
D	REVISED	
REV.	DESCRIPTION	
DOCUMENT NUMBER PS-5264-001		THIS DOCUMENT CONTAINS INFORMATION THAT IS PROPRIETARY TO INC. AND MUST NOT BE USED WITHOUT WRITTEN PERMISSION
		FILENAME PS000033.LWP
		SHEET 6 OF 10
ES-4000-3996 REV. A SHEET 4 95/MAR/10 EC U5-0926 DCBRD03.LWP		W to B 1 EN-37-1(019)



PRODUCT SPECIFICATION



LANGUAGE

JAPANESE
ENGLISH

項 目 Item		条 件 Test Condition	規 格 Requirement	
4-3-9	塩水噴霧 Salt Spray	コネクタを嵌合させ、35±2℃にて 5±1% 重量比の塩水を 48±4時間 噴霧し、試験後常温で水洗いした後、 室温で乾燥させる。 (JIS C0023/MIL-STD-202 試験法101) 48±4 hours exposure to a saltspray from the 5±1% solution at 35±2℃ (JIS C0023/ MIL-STD-202 Method 101)	外 観 Appearance	異常なきこと No Damage
			接触抵抗 Contact Resistance	40 milliohms MAX.
4-3-10	亜硫酸ガス SO ₂ Gas	コネクタを嵌合させ、40±2℃にて 50±5ppm の亜硫酸ガス中に 24時間 放置する。 24 hours exposure to 50±5ppm. SO ₂ gas at 40±2℃.	外 観 Appearance	異常なきこと No Damage
			接触抵抗 Contact Resistance	40 milliohms MAX.
4-3-11	耐アンモニア性 NH ₃ Gas	コネクタを嵌合させ、濃度 28% の アンモニア水を入れた容器中に 40分間 放置する。 (1L に対して 25mL の割合) 40 minutes exposure to NH ₃ gas evaporating from 28% Ammonia solution.	外 観 Appearance	異常なきこと No Damage
			接触抵抗 Contact Resistance	40 milliohms MAX.

D	REVISE ON PC ONLY	TITLE: 2.5 mm PITCH LOW PROFILE CONNECTOR 製品仕様書	
	REVISED		
	THIS DOCUMENT CONTAINS INFORMATION THAT IS PROPRIETARY TO INC. AND MUST NOT BE USED WITHOUT WRITTEN PERMISSION		
REV.	DESCRIPTION		
DOCUMENT NUMBER PS-5264-001		FILENAME PS000033.LWP	SHEET 7 OF 10
ES-4000-3996 REV. A SHEET 4 95/MAR/10 EC U5-0926 DCBRD03.LWP		W to B 1 EN-37-1(019)	



PRODUCT SPECIFICATION



LANGUAGE

JAPANESE
ENGLISH

項目 Item		条件 Test Condition	規格 Requirement	
4-3-12	半田付け性 Solderability	ターミナルまたはピンをフラックスに浸し、本体の取付け基準面より1.2mm迄、230±5℃の半田に3±0.5秒浸す。 Soldering Time: 3±0.5 second Solder Temperature: 230±5℃	濡れ性 Solder Wetting	浸漬面積の95%以上 95% of immersed area must show no voids, pin holes
4-3-13	半田耐熱性 Resistance to Soldering Heat	ディップの場合 <u>Soldering bath method</u> ターミナルまたはピンを本体の取付け基準面より1.2mm迄、260±5℃の半田に5±0.5秒浸す。 Soldering Time: 5±0.5 second Solder Temperature: 260±5℃	外観 Appearance	端子ガタ、割れ等 異状なきこと No Damage
		手半田の場合 <u>Soldering iron method</u> 350±5℃の半田ゴテにて3 ⁺¹ 秒加熱する。但し、端ピンに異常な加圧のないこと。 Soldering Time: 3 ⁺¹ second Solder Temperature: 350±5℃ However, without too much pressure to the terminal pin.		

() : 参考規格 Reference Standard

{ } : 参考単位 Reference Unit

【 5. 外観形状、寸法及び材質 PRODUCT SHAPE, DIMENSIONS AND MATERIALS 】

図面参照 Refer to the drawing.

REVISE ON PC ONLY		TITLE: 2.5 mm PITCH LOW PROFILE CONNECTOR 製品仕様書	THIS DOCUMENT CONTAINS INFORMATION THAT IS PROPRIETARY TO INC. AND MUST NOT BE USED WITHOUT WRITTEN PERMISSION	
D	REVISED			
REV.	DESCRIPTION			
DOCUMENT NUMBER PS-5264-001		FILENAME PS000033.LWP	SHEET 8 OF 10	
ES-4000-3996 REV. A SHEET 4 95/MAR/10 EC U5-0926 DCBRD03.LWP			W to B 1 EN-37-1(019)	



PRODUCT SPECIFICATION



LANGUAGE

JAPANESE
ENGLISH

【 6. 挿入力及び抜去力 INSERTION/WITHDRAWAL FORCE 】

極数 No. of CKT	単位 UNIT	挿入力 (最大値) Insertion (MAX.)			抜去力 (最小値) Withdrawal (MIN.)		
		初回 1st	6回目 6th	30回目 30th	初回 1st	6回目 6th	30回目 30th
2	N {kgf}	35.2 {3.6}	35.2 {3.6}	39.2 {4.0}	6.4 {0.65}	5.4 {0.55}	5.4 {0.55}
3	N {kgf}	43.1 {4.4}	43.1 {4.4}	47.0 {4.8}	6.9 {0.70}	5.9 {0.60}	5.9 {0.60}
4	N {kgf}	50.9 {5.2}	50.9 {5.2}	55.8 {5.7}	7.4 {0.75}	6.4 {0.65}	6.4 {0.65}
5	N {kgf}	58.8 {6.0}	58.8 {6.0}	63.7 {6.5}	7.9 {0.80}	6.9 {0.70}	6.9 {0.70}
6	N {kgf}	64.6 {6.6}	64.6 {6.6}	71.5 {7.3}	8.9 {0.90}	7.9 {0.80}	7.9 {0.80}
7	N {kgf}	70.5 {7.2}	70.5 {7.2}	78.4 {8.0}	9.8 {1.00}	8.9 {0.90}	8.9 {0.90}
8	N {kgf}	76.4 {7.8}	76.4 {7.8}	87.2 {8.9}	11.3 {1.15}	9.8 {1.00}	9.8 {1.00}
9	N {kgf}	62.7 {6.4}	62.7 {6.4}	72.5 {7.4}	10.6 {1.08}	8.9 {0.90}	8.9 {0.90}
10	N {kgf}	68.6 {7.0}	68.6 {7.0}	78.4 {8.0}	11.8 {1.20}	9.8 {1.00}	9.8 {1.00}
11	N {kgf}	74.4 {7.6}	74.4 {7.6}	84.2 {8.6}	13.0 {1.32}	10.8 {1.10}	10.8 {1.10}
12	N {kgf}	80.3 {8.2}	80.3 {8.2}	92.1 {9.4}	14.2 {1.44}	11.8 {1.20}	11.8 {1.20}
13	N {kgf}	86.2 {8.8}	86.2 {8.8}	98.9 {10.1}	15.3 {1.56}	12.8 {1.30}	12.8 {1.30}
14	N {kgf}	92.1 {9.4}	92.1 {9.4}	105.8 {10.8}	16.5 {1.68}	13.8 {1.40}	13.8 {1.40}
15	N {kgf}	98.0 {10.0}	98.0 {10.0}	112.7 {11.5}	17.7 {1.80}	14.7 {1.50}	14.7 {1.50}

REVISE ON PC ONLY		TITLE:	
D	REVISED	2.5 mm PITCH LOW PROFILE CONNECTOR 製品仕様書	
	DESCRIPTION		
REV.		THIS DOCUMENT CONTAINS INFORMATION THAT IS PROPRIETARY TO INC. AND MUST NOT BE USED WITHOUT WRITTEN PERMISSION	
DOCUMENT NUMBER		FILENAME	SHEET
PS-5264-001		PS000033.LWP	9 OF 10
ES-4000-3996 REV. A SHEET 4 95/MAR/10 EC U5-0926 DCBRD03.LWP			W to B 1
EN-37-1(019)			

EDP NO. 22-05-7**5
 ENG. NO. SD-5268-NA

MM DIMENSIONS IN METRIC DO NOT SCALE DRAWING

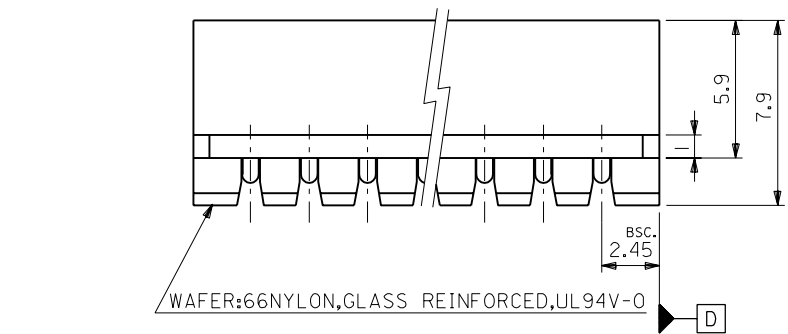
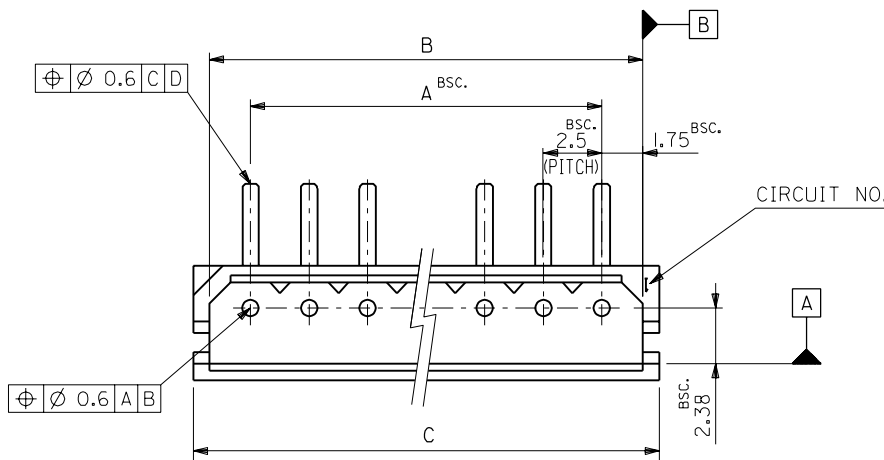

WAFER:66NYLON, GLASS REINFORCED, UL94V-0

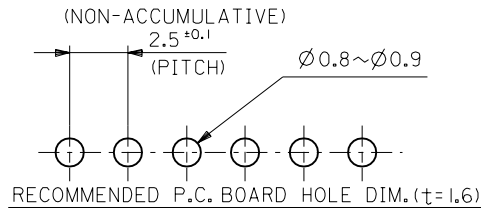

CIRCUIT NO.

NOTE:
 I.MATES WITH : 5264 SERIES.

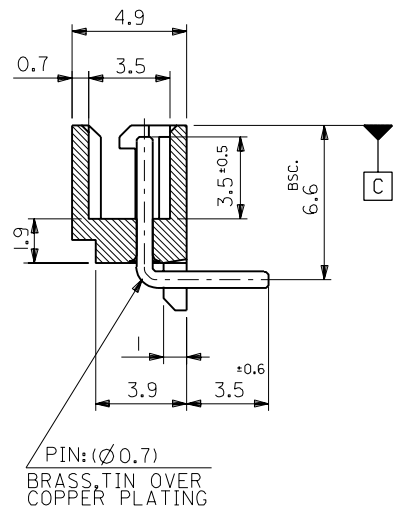

52.4	51	47.5	22-05-7205	5268-20A	20
49.9	48.5	45	-7195	-19A	19
47.4	46	42.5	-7185	-18A	18
44.9	43.5	40	-7175	-17A	17
42.4	41	37.5	-7165	-16A	16
39.9	38.5	35	-7155	-15A	15
37.4	36	32.5	-7145	-14A	14
34.9	33.5	30	-7135	-13A	13
32.4	31	27.5	-7125	-12A	12
29.9	28.5	25	-7115	-11A	11
27.4	26	22.5	-7105	-10A	10
24.9	23.5	20	-7095	-09A	9
22.4	21	17.5	-7085	-08A	8
19.9	18.5	15	-7075	-07A	7
17.4	16	12.5	-7065	-06A	6
14.9	13.5	10	-7055	-05A	5
12.4	11	7.5	-7045	-04A	4
9.9	8.5	5	-7035	-03A	3
7.4	6	2.5	22-05-7025	5268-02A	2
C	B	A	EDP NO.	ENG.NO.	CKT.

角度 ANGLE	±3°				
30以上 OVER	+0.3				
10以上 30未滿 UNDER	+0.25	C	REVISED & REDRAWN (J1059)	H.H.	9/11/05
10未滿 UNDER	+0.2	記号 LTR	変更内容 REVISION RECORD	DR. CHK.	日付 DATE
一般公差 GENERAL TOLERANCES		REVISE ONLY ON CAD SYSTEM			

材料 MATERIAL	— / —
仕上げ FINISH	— / —
適用電線範囲 WIRE RANGE	— / —
被覆外径 INS. RANGE	— / —
DRAWN BY K.TOJO '91/11/5	CHK'D BY '92/08/31
APP'D BY '92/08/31	M.ENOMOTO
尺度 SCALE	5-1

MOLEX-JAPAN CO.,LTD. 日本モレックス株式会社	
EDP. NO. 22-05-7**5	
ENG. NO. SD-5268-NA	REV C
TITLE 名称 2.5 LOW PROFILE WAFER ASS'Y 90° BEND	

THIS DRAWING CONTAINS INFORMATION THAT IS PROPRIETARY TO MOLEX(JAPAN) AND SHOULD NOT BE USED WITHOUT WRITTEN PERMISSION
 本図面は日本モレックス(株)の所有する情報を含むもので 当社の許可なく複製を禁止する。

MXJ-8

ENG. NO. SD-5268-NA

EDP NO. 22-05-7**5

MM DIMENSIONS IN METRIC DO NOT SCALE DRAWING

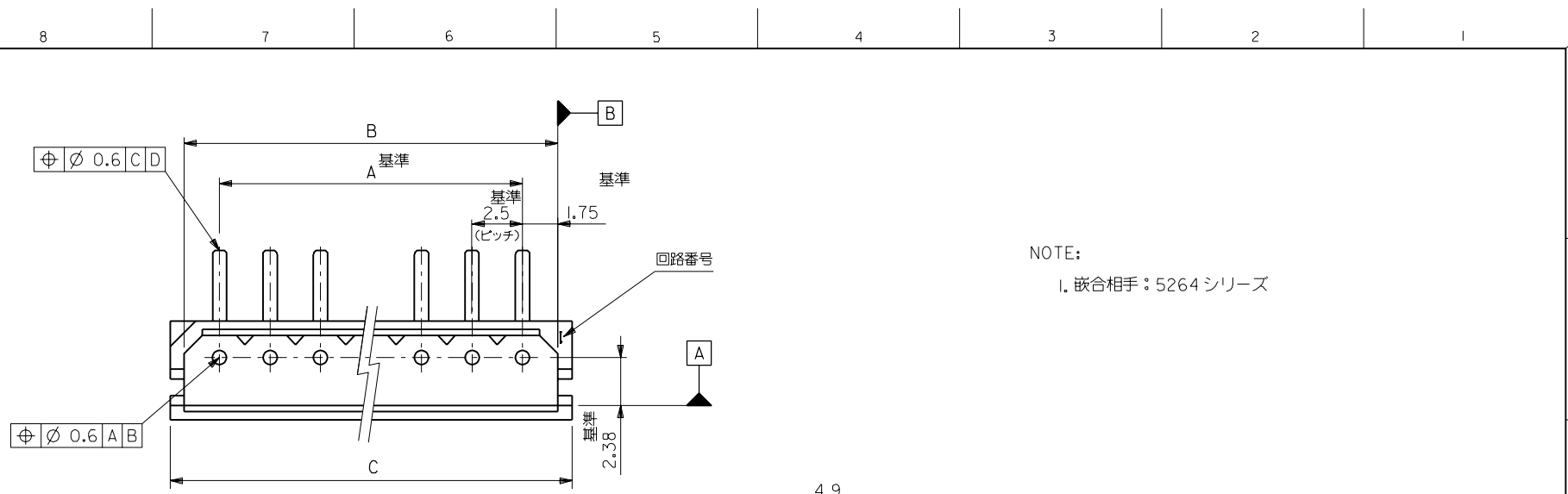

NOTE:
1. 嵌合相手: 5264 シリーズ

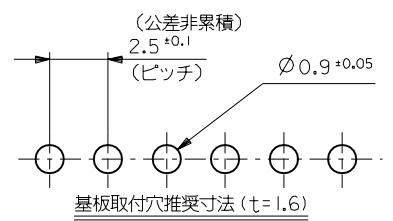
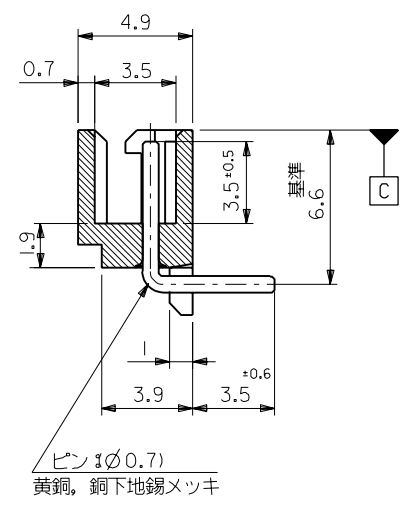
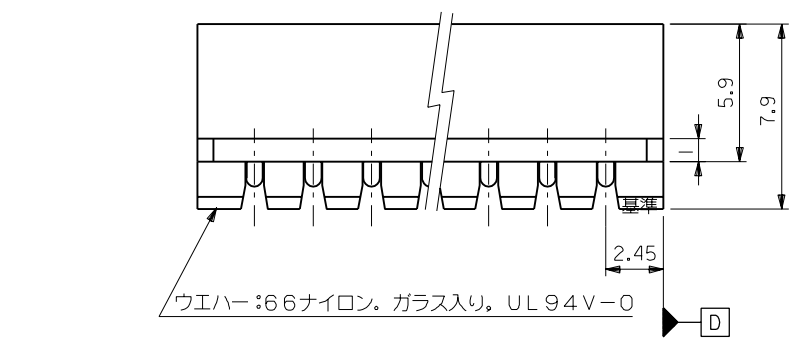

39.9	38.5	35	22-05-7155	5268-15A	15
37.4	36	32.5	-7145	-14A	14
34.9	33.5	30	-7135	-13A	13
32.4	31	27.5	-7125	-12A	12
29.9	28.5	25	-7115	-11A	11
27.4	26	22.5	-7105	-10A	10
24.9	23.5	20	-7095	-09A	9
22.4	21	17.5	-7085	-08A	8
19.9	18.5	15	-7075	-07A	7
17.4	16	12.5	-7065	-06A	6
14.9	13.5	10	-7055	-05A	5
12.4	11	7.5	-7045	-04A	4
9.9	8.5	5	-7035	-03A	3
7.4	6	2.5	22-05-7025	5268-02A	2
C	B	A	EDP NO.	ENG.NO.	極数

角度 ANGLE	+3°
30 以上 OVER	+0.3
10 以上 30 未満 UNDER	+0.25
10 未満 UNDER	+0.2
一般公差 GENERAL TOLERANCES	

材料 MATERIAL		MOLEX-JAPAN CO.,LTD. 日本モレックス株式会社
仕上げ FINISH		
適用電線範囲 WIRE RANGE		EDP. NO. 22-05-7**5
被覆外径 INS. RANGE		ENG. NO. SD-5268-NA
DRAWN BY K.TOJO '91/7/26	CHK'D BY '92/08/31	TITLE 名称 2.5 LOW PROFILE WAFER ASS'Y 90° BEND
APPD BY '92/08/31	M.ENOMOTO	尺度 SCALE 5-1

THIS DRAWING CONTAINS INFORMATION THAT IS PROPRIETARY TO MOLEX(JAPAN) AND SHOULD NOT BE USED WITHOUT WRITTEN PERMISSION
本図面は日本モレックス(株)の所有する情報を含むもので 当社の許可なく複製を禁止する。 MXJ-8