

NOTES

- I. MATERIAL
 WAFER : 66NYLON UL94V-0
 PIN : □0.635
 BRASS, GOLD(0.35μM MIN.)
 OVER NICKEL(2μM MIN.) PLATING
- △ TO BE APPLIED FOR 6CKT.
 AND MORE THAN 6CKT.
- △ NO SLIT IS PROVIDED FOR 5CKT.
 AND LESS THAN 5CKT.

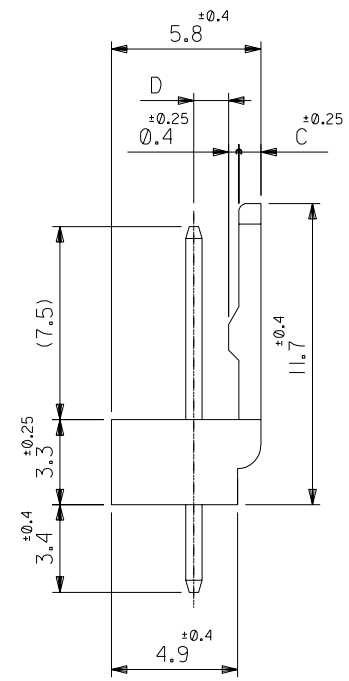
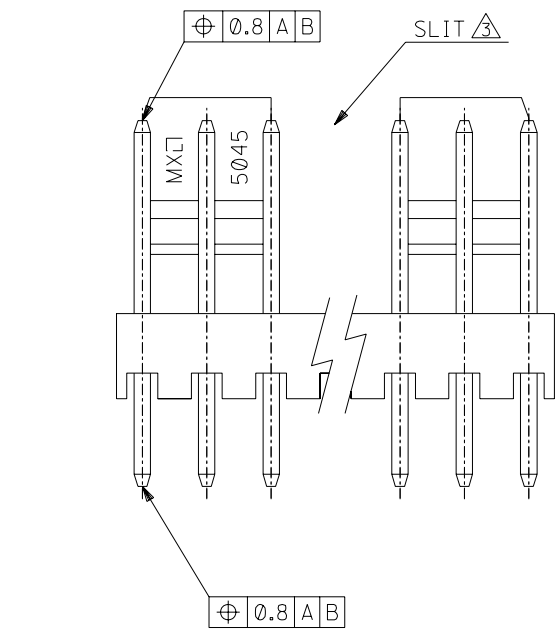

1.35	0.85	47.5 ^{+0.3} _{-0.45}	47.5	22-11-1201	5045-20AG	20
↑	↑	45 ^{+0.3} _{-0.45}	45	↑ -1191	↑ -19AG	19
		42.5 ^{+0.3} _{-0.45}	42.5	↑ -1181	↑ -18AG	18
		40 ^{+0.3} _{-0.45}	40	↑ -1171	↑ -17AG	17
		37.5 ^{+0.3} _{-0.45}	37.5	↑ -1161	↑ -16AG	16
		35 ^{+0.3} _{-0.45}	35	↑ -1151	↑ -15AG	15
		32.5 ^{+0.25} _{-0.45}	32.5	↑ -1141	↑ -14AG	14
		30 ^{+0.25} _{-0.4}	30	↑ -1131	↑ -13AG	13
		27.5 ^{+0.25} _{-0.4}	27.5	↑ -1121	↑ -12AG	12
		25 ^{+0.2} _{-0.4}	25	↑ -1111	↑ -11AG	11
		22.5 ^{+0.2} _{-0.4}	22.5	↑ -1101	↑ -10AG	10
		20 ^{+0.15} _{-0.35}	20	↑ -1091	↑ -09AG	9
		17.5 ^{+0.15} _{-0.35}	17.5	↑ -1081	↑ -08AG	8
		15 ^{+0.1} _{-0.3}	15	↑ -1071	↑ -07AG	7
		12.5 ^{+0.1} _{-0.3}	12.5	↑ -1061	↑ -06AG	6
		10 ^{+0.15} _{-0.3}	10	↑ -1051	↑ -05AG	5
↓	↓	7.5 ^{+0.15} _{-0.3}	7.5	↓ -1041	↓ -04AG	4
1.35	0.85	5 ^{+0.15} _{-0.3}	5	↓ -1031	↓ -03AG	3
1.2	1	2.5 ^{+0.15} _{-0.3}	2.5	22-11-1021	5045-02AG	2
D	C	B	A	EDP NO.	ENG. NO.	CKT.

材料 MATERIAL	SEE NOTES	molex MOLEX-JAPAN CO.,LTD. 日本モレックス株式会社	
仕上げ FINISH	— / —	EDP. NO. 22-11-1**1	
適用電線範囲 WIRE RANGE	— / —	ENG. NO. SD-5045-NAG	
被覆外径 INS. RANGE	— / —	REV E	
DRAWN BY '90/3/23 Y. MIZUNO	CHK'D BY '91/12/10 M. FUKUSHIMA	TITLE 名称 KK 2.5 WAFER ASS'Y WITH LOCK	
APP'D BY '91/12/10 M. NOMOTO	尺度 SCALE 5 - 1		
角度 ANGLE ±3°			
30以上 OVER ±0.3			
10以上 OVER 30未下 UNDER ±0.25	E REVISED & REDRAWN (100300)		
10未下 UNDER ±0.2	記号 変更内容 REVISION RECORD		
一般公差 GENERAL TOLERANCES	REVISE ONLY ON CAD SYSTEM		