

Distributed by:

JAMECO[®]
ELECTRONICS

www.Jameco.com ♦ 1-800-831-4242

The content and copyrights of the attached
material are the property of its owner.

Jameco Part Number 797136



PRODUCT SPECIFICATION

1.0 SCOPE

This Product Specification covers the 3.96 mm (.156 inch) centerline (pitch) 1.14mm (.045) square pin headers when mated with either printed circuit board (PCB) connectors or connectors terminated with 18 to 26 AWG wire using crimp technology.

2.0 PRODUCT DESCRIPTION

2.1 PRODUCT NAME AND SERIES NUMBERS

Crimp Terminals: 2478,2578,2878,2477,
Crimp Housings: 2139, 41695
PCB Connectors: 2145, 41815
Headers: 41771, 41772, 41791, 41792, 42471, 42472, 42491, 42492, 41661, 41662, 41671, 61672, 41681, 41682
Other products conforming to this specification are noted on the individual drawings.

2.2 DIMENSIONS, MATERIALS, PLATINGS AND MARKINGS

Terminal Material: Brass or Phos. Bronze (for Max performance use phos bronze material.)
Housing: Nylon or Polyester
Pins: Brass or Phos. Bronze
For more information on dimensions, materials, and plating see the individual drawings.

2.3 SAFETY AGENCY APPROVALS

UL File Number E29179
CSALR19980

3.0 APPLICABLE DOCUMENTS AND SPECIFICATIONS

None

4.0 RATINGS

4.1 VOLTAGE

250 Volts

4.2 CURRENT (Current is dependent on connector size, contact material, plating, ambient temperature, printed circuit board characteristics and related factors. Actual current rating is application dependent and should be evaluated for each application.)

a. For Crimp Terminals- and Applicable Wires

Wire Awg	Amps (Max) With Brass	Amps (Max) With Phos Bronze	Wire Insulation Dia
18	5.00	7.00	See terminal drawings
20	4.75	6.25	See terminal drawings
22	4.50	5.50	See terminal drawings
24	4.25	5.00	See terminal drawings
26	4.00	4.50	See terminal drawings

REVISION: R	ECR/ECN INFORMATION: EC No: UCR2002-0299 DATE: 2001 / 09 / 18	TITLE: PRODUCT SPECIFICATION .156 CENTER KK CONNECTORS	SHEET No. 1 of 5
DOCUMENT NUMBER: PS-08-50	CREATED / REVISED BY: SAMIEC	CHECKED BY: MUELLER	APPROVED BY: MARGULIS



PRODUCT SPECIFICATION

4.2 CURRENT (cont)

b. For Printed Circuit Board Connectors

Connector Style	Amps (Max) With Brass	Amps (Max) With Phos Bronze
Top Entry	4.50	5.00
Right Angle	4.50	5.00
Bottom Entry	4.00	4.50

4.3 TEMPERATURE (ambient + 30°C temp rise)

	Brass	Phos Bronze
Operating Temperature	0°C to +50°C	0°C to +75°C
Non Operating Temperature	-40°C to +105°C	-40°C to +105°C

5.0 PERFORMANCE

5.1 ELECTRICAL REQUIREMENTS

DESCRIPTION	TEST CONDITION	REQUIREMENT
Contact Resistance (Low Level)	Mate connectors: apply a maximum voltage of 20 mV and a current of 100 mA.	10 milliohms MAXIMUM [initial]
Contact Resistance of Wire Termination (Low Level)	Terminate the applicable wire to the terminal and measure wire using a voltage of 20 mV and a current of 100 mA.	2 milliohms MAXIMUM [initial]
Insulation Resistance	Unmate & unmount connectors: apply a voltage of 500 VDC between adjacent terminals and between terminals to ground.	1000 Megohms MINIMUM
Dielectric Withstanding Voltage	Unmate connectors: apply a voltage of {two times the rated voltage plus 1000 volts} VAC for 1 minute between adjacent terminals and between terminals to ground.	No breakdown
Capacitance	Measure between adjacent terminals at 1 MHz.	1.2 picofarads MAXIMUM
Temperature Rise (via Current Cycling)	Mate connectors: measure the temperature rise at the rated current after: 1) 96 hours (steady state) 2) 240 hours (45 minutes ON and 15 minutes OFF per hour) 3) 96 hours (steady state)	Temperature rise: +30°C MAXIMUM

REVISION: R	ECR/ECN INFORMATION: EC No: UCR2002-0299 DATE: 2001 / 09 / 18	TITLE: PRODUCT SPECIFICATION .156 CENTER KK CONNECTORS	SHEET No. 2 of 5
DOCUMENT NUMBER: PS-08-50	CREATED / REVISED BY: SAMIEC	CHECKED BY: MUELLER	APPROVED BY: MARGULIS



PRODUCT SPECIFICATION

5.2 MECHANICAL REQUIREMENTS

DESCRIPTION	TEST CONDITION	REQUIREMENT
Connector Mate and Unmate Forces	Per circuit when mated to an .045 Sq. pin. Mate and unmate connector (male to female) at a rate of 25 ± 6 mm ($1 \pm \frac{1}{4}$ inch) per minute.	10.0 N (2.25 lbf) MAXIMUM insertion force & 3.7 N (0.84 lbf) MINIMUM withdrawal force
Terminal Insertion Force (into Housing)	Apply an axial insertion force on the terminal at a rate of 25 ± 6 mm ($1 \pm \frac{1}{4}$ inch). (Forces will change with platings and materials.)	17.8 N (4.0 lbf) MAXIMUM insertion force
Terminal Retention Force (in Housing)	Axial pullout force on the terminal in the housing at a rate of 25 ± 6 mm ($1 \pm \frac{1}{4}$ inch) per minute. (Forces will change with platings and materials.)	35.6 N (8.0 lbf) MINIMUM withdrawal force
Durability	Mate connectors up to 25 cycles at a maximum rate of 10 cycles per minute prior to Environmental Tests.	10 milliohms MAXIMUM (change from initial)
Vibration (Random)	Mate connectors and vibrate per EIA 364-28, test condition VII.	10 milliohms MAXIMUM (change from initial) & Discontinuity < 1 microsecond
Shock (Mechanical)	Mate connectors and shock at 50 g's with $\frac{1}{2}$ sine wave (11 milliseconds) shocks in the $\pm X, \pm Y, \pm Z$ axes (18 shocks total).	10 milliohms MAXIMUM (change from initial) & Discontinuity < 1 microsecond
Wire Pullout Force (Axial)	Apply an axial pullout force on the wire at a rate of 25 ± 6 mm ($1 \pm \frac{1}{4}$ inch). (For maximum performance use Molex application tooling with stranded tinned copper wire)	18 awg = 89 N (20 lbf) 20 awg = 66 N (15 lbf) 22 awg = 53 N (12 lbf) 24 awg = 35 N (8 lbf) 26 awg = 22 N (5 lbf)
Normal Force	Apply a perpendicular force.	7.34 N (748 grams) average

REVISION: R	ECR/ECN INFORMATION: EC No: UCR2002-0299 DATE: 2001 / 09 / 18	TITLE: PRODUCT SPECIFICATION .156 CENTER KK CONNECTORS	SHEET No. 3 of 5
DOCUMENT NUMBER: PS-08-50	CREATED / REVISED BY: SAMIEC	CHECKED BY: MUELLER	APPROVED BY: MARGULIS



PRODUCT SPECIFICATION

5.3 ENVIRONMENTAL REQUIREMENTS

DESCRIPTION	TEST CONDITION	REQUIREMENT										
Shock (Thermal)	Mate connectors; expose to 5 cycles of: <table border="1"> <thead> <tr> <th>Temperature °C</th> <th>Duration (Minutes)</th> </tr> </thead> <tbody> <tr> <td>-40 +0/-3</td> <td>30</td> </tr> <tr> <td>+25 ±10</td> <td>5 MAXIMUM</td> </tr> <tr> <td>+105 +3/-0</td> <td>30</td> </tr> <tr> <td>+25 ±10</td> <td>5 MAXIMUM</td> </tr> </tbody> </table>	Temperature °C	Duration (Minutes)	-40 +0/-3	30	+25 ±10	5 MAXIMUM	+105 +3/-0	30	+25 ±10	5 MAXIMUM	10 milliohms MAXIMUM (change from initial) & Visual: No Damage
Temperature °C	Duration (Minutes)											
-40 +0/-3	30											
+25 ±10	5 MAXIMUM											
+105 +3/-0	30											
+25 ±10	5 MAXIMUM											
Thermal Aging	Mate connectors; expose to: 96 hours at 105 ± 2°C	10 milliohms MAXIMUM (change from initial]) & Visual: No Damage										
Humidity (Steady State)	Mate connectors: expose to a temperature of 40 ± 2°C with a relative humidity of 90-95% for 96 hours. Note: Remove surface moisture and air dry for 1 hour prior to measurements.	10 milliohms MAXIMUM (change from initial) & Dielectric Withstanding Voltage: No Breakdown at 500 VAC & Insulation Resistance: 1000 Megohms MINIMUM & Visual: No Damage										
Humidity (Cyclic)	Mate connectors: cycle per EIA-364-31: 24 cycles at temperature 25 ± 3°C at 80 ± 5% relative humidity and 65 ± 3°C at 50 ± 5% relative humidity; dwell time of 1.0 hour; ramp time of 0.5 hours. {Note: Remove surface moisture and air dry for 1 hour prior to measurements.}	10 milliohms MAXIMUM (change from initial) & Dielectric Withstanding Voltage: No Breakdown at 500 VAC & Insulation Resistance: 1000 Megohms MINIMUM & Visual: No Damage										
Solderability	Per SMES-152	Solder coverage: 95% MINIMUM (per SMES-152)										

REVISION: R	ECR/ECN INFORMATION: EC No: UCR2002-0299 DATE: 2001 / 09 / 18	TITLE: PRODUCT SPECIFICATION .156 CENTER KK CONNECTORS	SHEET No. 4 of 5
DOCUMENT NUMBER: PS-08-50	CREATED / REVISED BY: SAMIEC	CHECKED BY: MUELLER	APPROVED BY: MARGULIS



PRODUCT SPECIFICATION

5.3 ENVIRONMENTAL REQUIREMENTS

DESCRIPTION	TEST CONDITION	REQUIREMENT
Solder Resistance	Dip connector terminal tails in solder: Solder Duration: 5 ± 0.5 seconds; Solder Temperature: $230 \pm 5^\circ\text{C}$	Visual: No Damage to insulator material
Salt Spray	Mate connectors: Duration: 48 hours exposure; Atmosphere: salt spray from a 5% solution; Temperature: $35 +1/-2^\circ\text{C}$	10 milliohms MAXIMUM (change from initial) & Visual: No Damage
Cold Resistance	Mate connectors: Duration: 96 hours; Temperature: $-40 \pm 3^\circ\text{C}$	10 milliohms MAXIMUM (change from initial) & Visual: No Damage
Corrosive Atmosphere: Flowing Mixed Gas (FMG)	Mate connectors: Test per EIA-364-65, method 2A	10 milliohms MAXIMUM (change from initial) & Visual: No Damage

6.0 PACKAGING

Parts shall be packaged to protect against damage during handling, transit and storage.

7.0 GAGES AND FIXTURES

8.0 OTHER

REVISION: R	ECR/ECN INFORMATION: EC No: UCR2002-0299 DATE: 2001 / 09 / 18	TITLE: PRODUCT SPECIFICATION .156 CENTER KK CONNECTORS	SHEET No. 5 of 5
DOCUMENT NUMBER: PS-08-50	CREATED / REVISED BY: SAMIEC	CHECKED BY: MUELLER	APPROVED BY: MARGULIS

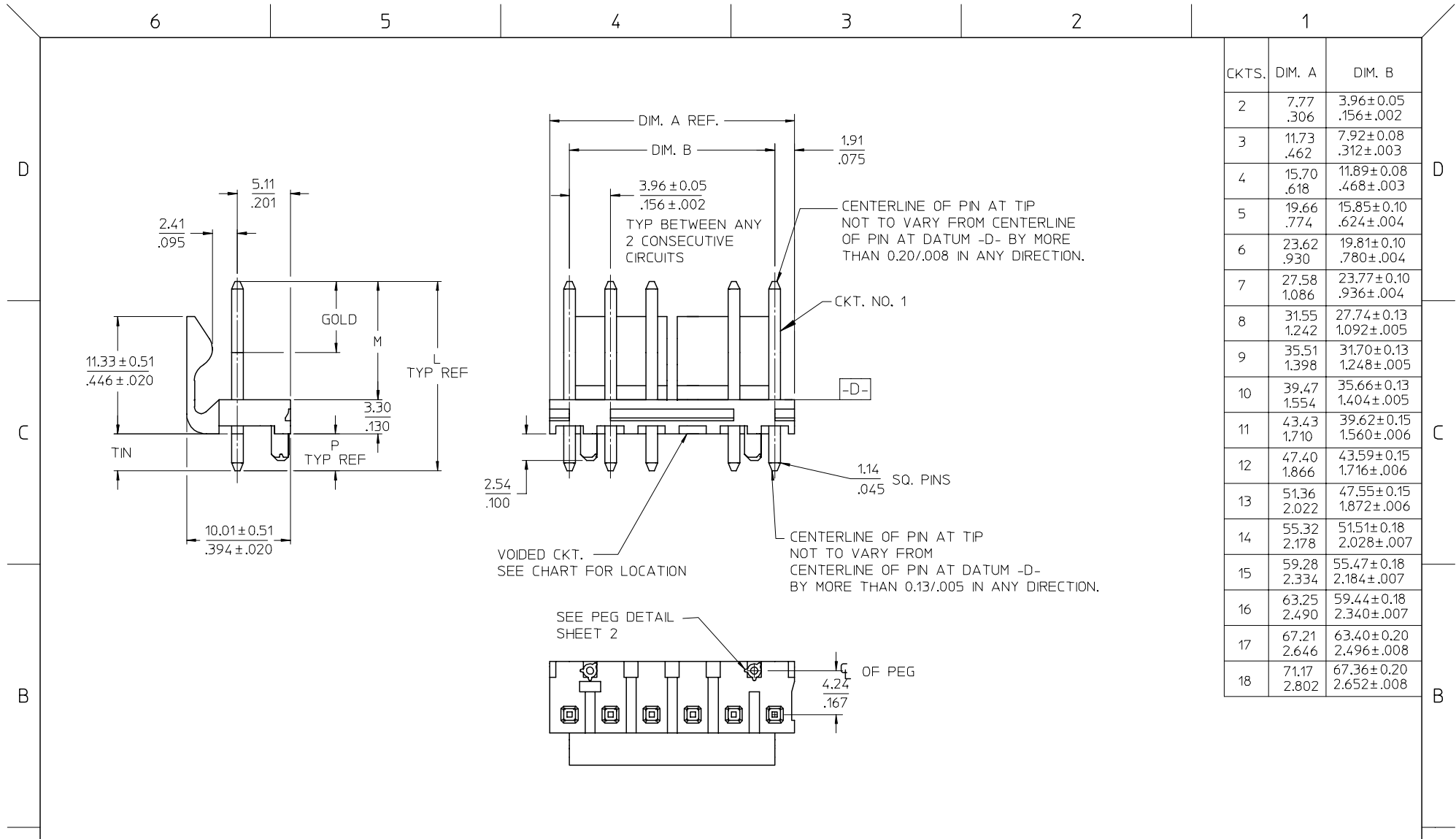

CKTS.	DIM. A	DIM. B
2	7.77 .306	3.96±0.05 .156±.002
3	11.73 .462	7.92±0.08 .312±.003
4	15.70 .618	11.89±0.08 .468±.003
5	19.66 .774	15.85±0.10 .624±.004
6	23.62 .930	19.81±0.10 .780±.004
7	27.58 1.086	23.77±0.10 .936±.004
8	31.55 1.242	27.74±0.13 1.092±.005
9	35.51 1.398	31.70±0.13 1.248±.005
10	39.47 1.554	35.66±0.13 1.404±.005
11	43.43 1.710	39.62±0.15 1.560±.006
12	47.40 1.866	43.59±0.15 1.716±.006
13	51.36 2.022	47.55±0.15 1.872±.006
14	55.32 2.178	51.51±0.18 2.028±.007
15	59.28 2.334	55.47±0.18 2.184±.007
16	63.25 2.490	59.44±0.18 2.340±.007
17	67.21 2.646	63.40±0.20 2.496±.008
18	71.17 2.802	67.36±0.20 2.652±.008

REVISE PER ECN EC NO: UCP2006-1218 DRWN:DPETERSON 2006/01/25 CHKD:ADERR 2006/01/31 APPR:FSMITH 2006/02/02 F1	QUALITY SYMBOLS ▽=0 ▽=0	GENERAL TOLERANCES (UNLESS SPECIFIED)		DIMENSION STYLE MM/IN		SCALE 2:1	DESIGN UNITS INCH	THIRD ANGLE PROJECTION	
		4 PLACES ± --- ± ---	mm	INCH	DRAWN BY SCHAFFER	DATE 11-14-03	TITLE KK 156 HEADER ASSEMBLY FRICTION LOCK VERTICAL PEGS		
		3 PLACES ± --- ± .010			CHECKED BY SAMIEC	DATE 11-14-03			
		2 PLACES ± 0.25 ± .015			APPROVED BY MARGULIS	DATE 11-14-03	MOLEX INCORPORATED DOCUMENT NO. SD-42491-001		
1 PLACE ± 0.38 ± ---			MATERIAL NO. SEE CHART		SHEET NO. 1 OF 2				
ANGULAR ± 1/2°		DRAFT WHERE APPLICABLE MUST REMAIN WITHIN DIMENSIONS		SIZE A				THIS DRAWING CONTAINS INFORMATION THAT IS PROPRIETARY TO MOLEX INCORPORATED AND SHOULD NOT BE USED WITHOUT WRITTEN PERMISSION	

6

5

4

3

2

1

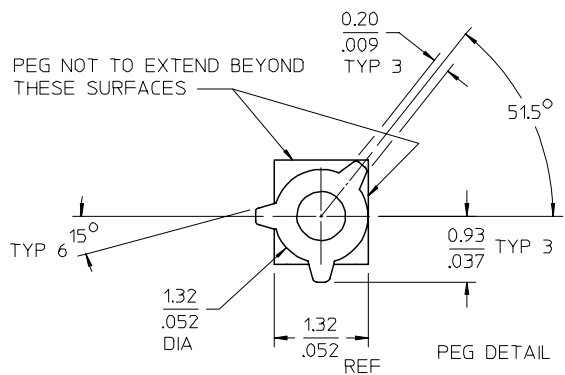

NOTES:

- MATERIAL: HEADER-POLYESTER, 94V-0, MOLDED NATURAL (WHITE)
PINS: BRASS
- FINISHES: (102) TIN 0.00508/.000200 MIN. OVER 0.00254/.000100 MIN. COPPER.
(208) SELECT GOLD 0.00038/.000015 MIN. SELECT TIN 0.00254/.000100 MIN. OVER NICKEL
(228) SELECT GOLD 0.00076/.000030 MIN. SELECT TIN 0.00254/.000100 MIN. OVER NICKEL
- PRODUCT SPECIFICATION: SEE PS-08-50.
- PACKAGING INFORMATION: SEE CHARTS.
- SOLDERABILITY: WHEN PARTS ARE SOLDERED AT A TEMPERATURE OF 230°C (446°F) FOR 5 SECONDS, EACH SOLDERED SURFACE SHALL BE A MINIMUM OF 95% COVERED.
- PIN PUSH OUT FORCE: PRIOR TO SOLDERING = 3 LB MINIMUM FORCE (IN EITHER DIRECTION) SHALL BE REQUIRED TO PUSH THE PIN OUT OF THE HEADER.
- PARTS ARE STACKABLE END TO END ON (3.96)/.156 CENTERS.
- FOR PART WITHOUT PEGS SEE DWG. NO. SDA-41791.

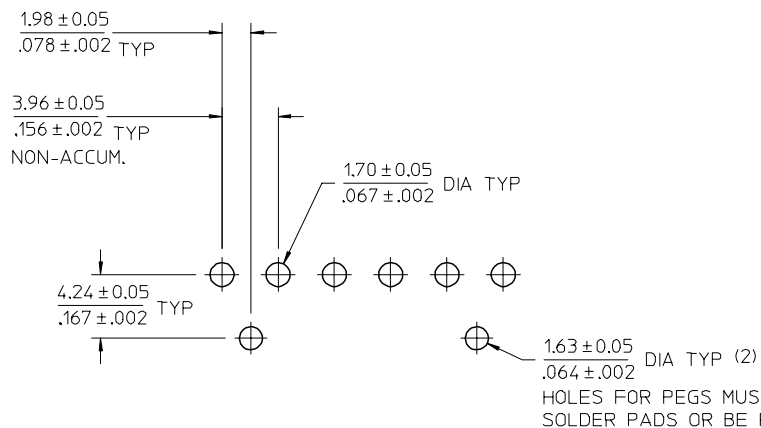

PCB LAYOUT: COMPONENT SIDE

UPDATE PER ECN EC NO: UCP2006-1218 DRWN:DPETERSON 2006/01/25 CHKD:ADERR 2006/01/31 APPR:FSMITH 2006/02/02	DESCRIPTION REV	QUALITY SYMBOLS ▽=0 ▽=0	GENERAL TOLERANCES (UNLESS SPECIFIED)		DIMENSION STYLE MM/IN		SCALE 1:1	DESIGN UNITS INCH	THIRD ANGLE PROJECTION	
			mm	INCH	DRAWN BY	DATE	TITLE KK 156 HEADER ASSEMBLY FRICTION LOCK VERTICAL PEGS			
		4 PLACES	± ---	± ---	SCHAFFER	11-14-03				
		3 PLACES	± ---	± .010	CHECKED BY	DATE	MOLEX INCORPORATED			
2 PLACES	± 0.25	± .015	SAMIEC	11-14-03						
1 PLACE	± 0.38	± ---	APPROVED BY	DATE	MATERIAL NO. SEE CHART		DOCUMENT NO. SD-42491-001		SHEET NO. 2 OF 2	
			ANGULAR ± 1/2°		THIS DRAWING CONTAINS INFORMATION THAT IS PROPRIETARY TO MOLEX INCORPORATED AND SHOULD NOT BE USED WITHOUT WRITTEN PERMISSION					

DRAFT WHERE APPLICABLE
MUST REMAIN
WITHIN DIMENSIONS

SIZE
A

5

4

3

2

1

OPTIONS	Group	A-42491-0002/0018	Group	A-42491-0312/0328	Group	A-42491-0329/0345	Group	
	Header No:	41790-0019/0035	Header No:	41790-0019/0035	Header No:	41790-0019/0035	Header No:	
	Pin No:	2161-94(102)	Pin No:	43294-0209	Pin No:	43294-0210	Pin No:	
	Plating:	102 – TIN	Plating:	208 – 15 GOLD	Plating:	228 – 30 GOLD	Plating:	
	Pin Length L	18.29 / .720	Pin Length L	18.29/. 720	Pin Length L	18.29/. 720	Pin Length L	
	Mating M	11.43 / .450	Mating M	11.43/. 450	Mating M	11.43/. 450	Mating M	
	Gold Loc G	N/A	Gold Loc G	6.86/. 270	Gold Loc G	6.86/. 270	Gold Loc G	
	PC Tail P	3.56 / .140	PC Tail P	3.56/. 140	PC Tail P	3.56/. 140	PC Tail P	
	Tin Loc T	OVERALL	Tin Loc T	4.06/. 160	Tin Loc T	4.06/. 160	Tin Loc T	
	Voided Ckts	NONE	Voided Ckts	NONE	Voided CKts	NONE	Voided Ckts	
Pack Per	PK-42491-001	Pack Per	PK-42491-001	Pack Per	PK-42491-001	Pack Per		
Ckts	Material No	Engineer Number	Material No	Engineer Number	Material No	Engineer Number	Material No	Engineer Number
2	26-64-4020	A-42491-0002	42491-0312	A-42491-0312	42491-0329	A-42491-0329		
3	26-64-4030	A-42491-0003	42491-0313	A-42491-0313	42491-0330	A-42491-0330		
4	26-64-4040	A-42491-0004	42491-0314	A-42491-0314	42491-0331	A-42491-0331		
5	26-64-4050	A-42491-0005	42491-0315	A-42491-0315	42491-0332	A-42491-0332		
6	26-64-4060	A-42491-0006	42491-0316	A-42491-0316	42491-0333	A-42491-0333		
7	26-64-4070	A-42491-0007	42491-0317	A-42491-0317	42491-0334	A-42491-0334		
8	26-64-4080	A-42491-0008	42491-0318	A-42491-0318	42491-0335	A-42491-0335		
9	26-64-4090	A-42491-0009	42491-0319	A-42491-0319	42491-0336	A-42491-0336		
10	26-64-4100	A-42491-0010	42491-0320	A-42491-0320	42491-0337	A-42491-0337		
11	26-64-4110	A-42491-0011	42491-0321	A-42491-0321	42491-0338	A-42491-0338		
12	26-64-4120	A-42491-0012	42491-0322	A-42491-0322	42491-0339	A-42491-0339		
13	X26-64-4130	A-42491-0013	X42491-0323	A-42491-0323	X42491-0340	A-42491-0340		
14	X26-64-4140	A-42491-0014	X42491-0324	A-42491-0324	X42491-0341	A-42491-0341		
15	X26-64-4150	A-42491-0015	X42491-0325	A-42491-0325	X42491-0342	A-42491-0342		
16	X26-64-4160	A-42491-0016	X42491-0326	A-42491-0326	X42491-0343	A-42491-0343		
17	X26-64-4170	A-42491-0017	X42491-0327	A-42491-0327	X42491-0344	A-42491-0344		
18	X26-64-4180	A-42491-0018	X42491-0328	A-42491-0328	X42491-0345	A-42491-0345		

REV: F1	X-OBSOLETE 2/2/2006	TITLE: KK 156 HEADER ASSEMBLY FRICTION LOCK VERTICAL PEGS	SHEET No. - 3 -
DOCUMENT NUMBER: SD- 42491-001	CREATED / REVISED BY: DPETERSON	CHECKED BY: ADERR	APPROVED BY: FSMITH

OPTIONS	Group	A-42491-0019/0035	Group	A-42491-0036/0052	Group	A-42491-0059/0074	Group	A-42491-0086-0100
	Header No:	41790-0019/0035	Header No:	41790-0019/0035	Header No:	41790-0020/0035	Header No:	41790-0021/0035
	Pin No:	2161-94(501)	Pin No:	2161-94(102)	Pin No:	2161-94(102)	Pin No:	2161-94(102)
	Plating:	501 - GOLD	Plating:	102 - TIN	Plating:	102 - TIN	Plating:	102 - TIN
	Pin Length L	18.29 / .720	Pin Length L	18.29/. 720	Pin Length L	18.29/. 720	Pin Length L	18.29/. 720
	Mating M	11.43 / .450	Mating M	11.43/. 450	Mating M	11.43/. 450	Mating M	11.43/. 450
	Gold Loc G	OVERALL	Gold Loc G	N/A	Gold Loc G	N/A	Gold Loc G	N/A
	PC Tail P	3.56 / .140	PC Tail P	3.56/. 140	PC Tail P	3.56/. 140	PC Tail P	3.56/. 140
	Tin Loc T	N/A	Tin Loc T	OVERALL	Tin Loc T	OVERALL	Tin Loc T	OVERALL
	Voided Ckts	NONE	Voided Ckts	2	Voided CKts	3	Voided Ckts	2, 4
Pack Per	PK-42491-001	Pack Per	PK-42491-001	Pack Per	PK-42491-001	Pack Per	PK-42491-001	
Ckts	Material No	Engineer Number	Material No	Engineer Number	Material No	Engineer Number	Material No	Engineer Number
2	26-65-4020	A-42491-0019						
3	26-65-4030	A-42491-0020	26-62-4035	A-42491-0037	27-62-4032	A-42491-0059		
4	26-65-4040	A-42491-0021	26-62-4045	A-42491-0038	27-62-4042	A-42491-0060		A-42491-0086
5	26-65-4050	A-42491-0022	26-62-4055	A-42491-0039	27-62-4052	A-42491-0061		A-42491-0087
6	26-65-4060	A-42491-0023	26-62-4065	A-42491-0040	27-62-4062	A-42491-0062	27-60-4061	A-42491-0088
7	26-65-4070	A-42491-0024	26-62-4075	A-42491-0041	27-62-4072	A-42491-0063		A-42491-0089
8	26-65-4080	A-42491-0025	26-62-4085	A-42491-0042	27-62-4082	A-42491-0064		A-42491-0090
9	26-65-4090	A-42491-0026	26-62-4095	A-42491-0043	27-62-4092	A-42491-0065		A-42491-0091
10	26-65-4100	A-42491-0027	26-62-4105	A-42491-0044	27-62-4102	A-42491-0066		A-42491-0092
11	26-65-4110	A-42491-0028	26-62-4115	A-42491-0045	27-62-4112	A-42491-0067		A-42491-0093
12	26-65-4120	A-42491-0029	26-62-4125	A-42491-0046	27-62-4122	A-42491-0068		A-42491-0094
13	X26-65-4130	A-42491-0030	X26-62-4135	A-42491-0047	X27-62-4132	A-42491-0069	X	A-42491-0095
14	X26-65-4140	A-42491-0031	X26-62-4145	A-42491-0048	X27-62-4142	A-42491-0070	X	A-42491-0096
15	X26-65-4150	A-42491-0032	X26-62-4155	A-42491-0049	X27-62-4152	A-42491-0071	X	A-42491-0097
16	X26-65-4160	A-42491-0033	X26-62-4165	A-42491-0050	X27-62-4162	A-42491-0072	X	A-42491-0098
17	X26-65-4170	A-42491-0034	X26-62-4175	A-42491-0051	X27-62-4172	A-42491-0073	X	A-42491-0099
18	X26-65-4180	A-42491-0035	X26-62-4185	A-42491-0052	X27-62-4182	A-42491-0074	X	A-42491-0100

REV: F1	X-OBSOLETE 2/2/2006	TITLE: KK 156 HEADER ASSEMBLY FRICTION LOCK VERTICAL PEGS	SHEET No. - 4 -
DOCUMENT NUMBER: SD- 42491-001	CREATED / REVISED BY: DPETERSON	CHECKED BY: ADERR	APPROVED BY: FSMITH

OPTIONS	Group	A-42491-0172/0188	Group	A-42491-0223/0239	Group	A-42491-0240/0251	Group	A-42491-0252/0265
	Header No:	41790-0019/0035	Header No:	41790-0019/0035	Header No:	41790-0023/0035	Header No:	41790-0022/0035
	Pin No:	2161-36(102)	Pin No:	2161-1(122)	Pin No:	2161-94(102)	Pin No:	2161-94(102)
	Plating:	102 - TIN	Plating:	122 - TIN	Plating:	102 - TIN	Plating:	102 - TIN
	Pin Length L	30.48/ 1.200	Pin Length L	19.05/ .750	Pin Length L	18.29/ .720	Pin Length L	18.29/ .720
	Mating M	13.28/ .523	Mating M	11.43/ .450	Mating M	11.43/ .450	Mating M	11.43/ .450
	Gold Loc G	N/A	Gold Loc G	N/A	Gold Loc G	N/A	Gold Loc G	N/A
	PC Tail P	13.89/ .547	PC Tail P	4.32/ .170	PC Tail P	3.56/ .140	PC Tail P	3.56/ .140
	Tin Loc T	OVERALL	Tin Loc T	OVERALL	Tin Loc T	OVERALL	Tin Loc T	OVERALL
	Voided Ckts	NONE	Voided Ckts	NONE	Voided CKts	7	Voided Ckts	5
Pack Per	PK-42491-003	Pack Per	PK-42491-001	Pack Per	PK-42491-001	Pack Per	PK-42491-001	
Ckts	Material No	Engineer Number	Material No	Engineer Number	Material No	Engineer Number	Material No	Engineer Number
2		A-42491-0172	42491-0223	A-42491-0223				
3		A-42491-0173	42491-0224	A-42491-0224				
4		A-42491-0174	42491-0225	A-42491-0225				
5		A-42491-0175	42491-0226	A-42491-0226			42491-0252	A-42491-0252
6	26-64-4061	A-42491-0176	42491-0227	A-42491-0227			27-62-4068	A-42491-0253
7		A-42491-0177	42491-0228	A-42491-0228	42491-0240	A-42491-0240	42491-0254	A-42491-0254
8		A-42491-0178	42491-0229	A-42491-0229	27-62-4087	A-42491-0241	42491-0255	A-42491-0255
9		A-42491-0179	42491-0230	A-42491-0230	42491-0242	A-42491-0242	42491-0256	A-42491-0256
10		A-42491-0180	42491-0231	A-42491-0231	42491-0243	A-42491-0243	42491-0257	A-42491-0257
11		A-42491-0181	42491-0232	A-42491-0232	42491-0244	A-42491-0244	42491-0258	A-42491-0258
12		A-42491-0182	42491-0233	A-42491-0233	42491-0245	A-42491-0245	42491-0259	A-42491-0259
13	X	A-42491-0183	X42491-0234	A-42491-0234	X42491-0246	A-42491-0246	X42491-0260	A-42491-0260
14	X	A-42491-0184	X42491-0235	A-42491-0235	X42491-0247	A-42491-0247	X42491-0261	A-42491-0261
15	X	A-42491-0185	X42491-0236	A-42491-0236	X42491-0248	A-42491-0248	X42491-0262	A-42491-0262
16	X	A-42491-0186	X42491-0237	A-42491-0237	X42491-0249	A-42491-0249	X42491-0263	A-42491-0263
17	X	A-42491-0187	X42491-0238	A-42491-0238	X42491-0250	A-42491-0250	X42491-0264	A-42491-0264
18	X	A-42491-0188	X42491-0239	A-42491-0239	X42491-0251	A-42491-0251	X42491-0265	A-42491-0265

REV: F1	X-OBSOLETE 2/2/2006	TITLE: KK 156 HEADER ASSEMBLY FRICTION LOCK VERTICAL PEGS	SHEET No. - 5 -
DOCUMENT NUMBER: SD- 42491-001	CREATED / REVISED BY: DPETERSON	CHECKED BY: ADERR	APPROVED BY: FSMITH

OPTIONS	Group	A-42491-0266/0275	Group	A-42491-0276/0286	Group	A-42491-0287/0299	Group	A-42491-0300/0311
	Header No:	41790-0026/0035	Header No:	41790-0025/0035	Header No:	41790-0024/0035	Header No:	41790-0025/0035
	Pin No:	2161-94(102)	Pin No:	2161-94(102)	Pin No:	2161-94(102)	Pin No:	2161-94(102)
	Plating:	102 - TIN	Plating:	102 - TIN	Plating:	102 - TIN	Plating:	102 - TIN
	Pin Length L	18.29/ .720	Pin Length L	18.29/ .720	Pin Length L	18.29/ .720	Pin Length L	18.29/ .720
	Mating M	11.43 / .450	Mating M	11.43/ .450	Mating M	11.43/ .450	Mating M	11.43/ .450
	Gold Loc G	N/A	Gold Loc G	N/A	Gold Loc G	N/A	Gold Loc G	N/A
	PC Tail P	13.89/ .547	PC Tail P	3.56/ .140	PC Tail P	3.56/ .140	PC Tail P	3.56/ .140
	Tin Loc T	OVERALL	Tin Loc T	OVERALL	Tin Loc T	OVERALL	Tin Loc T	OVERALL
	Voided Ckts	3, 5, 6, 8, 9	Voided Ckts	2, 3, 5, 6, 8	Voided CKts	3, 6	Voided Ckts	2, 5, 7
Pack Per	PK-42491-001	Pack Per	PK-42491-001	Pack Per	PK-42491-001	Pack Per		
Ckts	Material No	Engineer Number	Material No	Engineer Number	Material No	Engineer Number	Material No	Engineer Number
2								
3								
4								
5								
6								
7								
8			42491-0276	A-42491-0276	42491-0287	A-42491-0287		
9	42491-0266	A-42491-0266	42491-0277	A-42491-0277	42491-0288	A-42491-0288	42491-0300	A-42491-0300
10	27-66-4104	A-42491-0267	27-66-4105	A-42491-0278	42491-0289	A-42491-0289	42491-0301	A-42491-0301
11	42491-0268	A-42491-0268	42491-0279	A-42491-0279	42491-0290	A-42491-0290	42491-0302	A-42491-0302
12	42491-0269	A-42491-0269	42491-0280	A-42491-0280	42491-0291	A-42491-0291	42491-0303	A-42491-0303
13	X42491-0270	A-42491-0270	X42491-0281	A-42491-0281	42491-0292	A-42491-0292	42491-0304	A-42491-0304
14	X42491-0271	A-42491-0271	X42491-0282	A-42491-0282	42491-0293	A-42491-0293	42491-0305	A-42491-0305
15	X42491-0272	A-42491-0272	X42491-0283	A-42491-0283	X42491-0294	A-42491-0294	X42491-0306	A-42491-0306
16	X42491-0273	A-42491-0273	X42491-0284	A-42491-0284	X42491-0295	A-42491-0295	X42491-0307	A-42491-0307
17	X42491-0274	A-42491-0274	X42491-0285	A-42491-0285	X42491-0296	A-42491-0296	X42491-0308	A-42491-0308
18	X42491-0275	A-42491-0275	X42491-0286	A-42491-0286	X42491-0297	A-42491-0297	X42491-0309	A-42491-0309
					X42491-0298	A-42491-0298	X42491-0310	A-42491-0310
					X42491-0299	A-42491-0299	X42491-0311	A-42491-0311

REV: F1	X-OBSOLETE 2/2/2006	TITLE: KK 156 HEADER ASSEMBLY FRICTION LOCK VERTICAL PEGS	SHEET No. - 6 -
DOCUMENT NUMBER: SD- 42491-001	CREATED / REVISED BY: DPETERSON	CHECKED BY: ADERR	APPROVED BY: FSMITH

