

REF. -50 OPT. SCREW
(WHERE APPLICABLE)

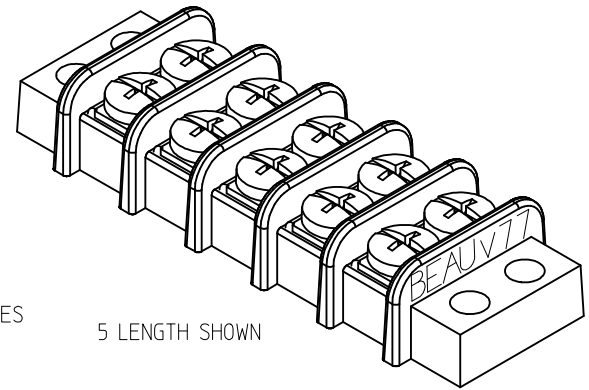
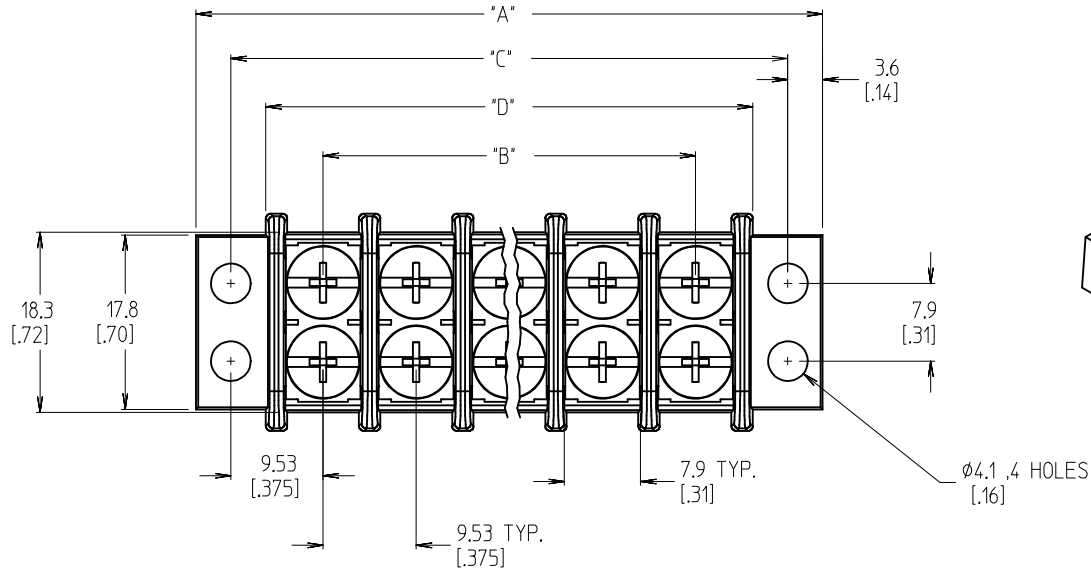

5 LENGTH SHOWN

NOTES:

1. MATERIAL: SEE TABLE
2. FINISHES: SEE TABLE
3. INCH DIMS ARE SHOWN IN BRACKETS [XXX]
4. "XX" REFERS TO THE QUANTITY OF CIRCUITS.
5. -61 OPTION: ONE ROW OF SCREWS NOT SUPPLIED. SCREW QUANTITY = "XX".
6. -49 OPTION: USE ITEM 3 TERMINAL PLATE. ALL OTHERS USE ITEM 2.
7. -58 OPTION: NO SCREWS SUPPLIED. (B)
8. FOR IMPRINTING (-10A OPTION) SEE SD-38120-001.
9. ALL COMPONENTS ARE ROHS COMPLIANT.

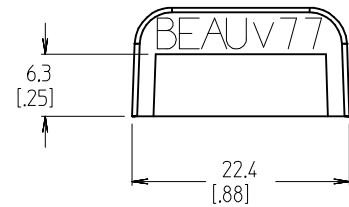
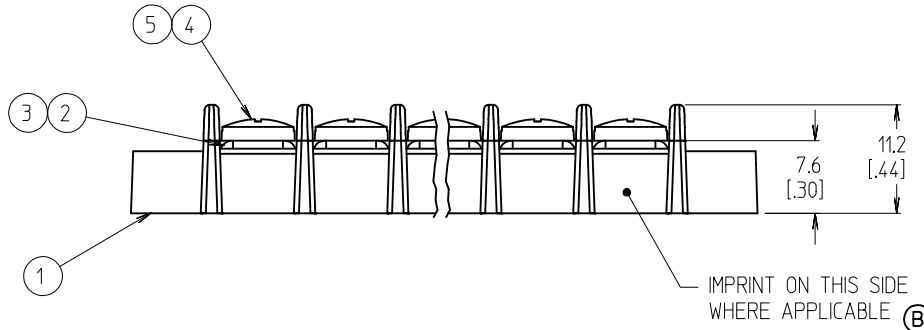

ITEM	QTY.	DESCRIPTION	MATERIAL NO.	ENGINEERING NO.
6	XX*2	SCREW&WASHER, #6-32X.250, PAN, PHIL-SLOT (-50)	STEEL	ZINC W/CHROMATE
5	XX*2	SCREW, #6-32X.250, BHD, PHIL-SLOT (-49)	BRASS	NICKEL PLATE
4	XX*2	SCREW, #6-32X.250, BHD, PHIL-SLOT (STD &-61)	STEEL	ZINC W/CHROMATE
3	XX	TERMINAL PLATE, TIN PLATED (SEE NOTE 6)	BRASS	TIN PLATE
2	XX	TERMINAL PLATE, NICKEL PLATED	BRASS	NICKEL PLATE
1	1	INSULATOR	PBT	BLACK

REMOVE -45 PARTS, ADD -10A
 EC NO: IPG2014-1260
 /DRWN: JENC INAS 2013/10/14
 /CHKD: JMACNEIL 2014/02/07
 /APPR: JMACNEIL 2014/03/10

QUALITY SYMBOLS
 ▼=0
 ▽=0

GENERAL TOLERANCES (UNLESS SPECIFIED)	
mm	INCH
4 PLACES ± ---	± ---
3 PLACES ± ---	± .005
2 PLACES ± 0.13	± .01
1 PLACE ± 0.3	± ---
ANGULAR ± 2 °	

DRAFT WHERE APPLICABLE
 MUST REMAIN WITHIN DIMENSIONS

DIMENSION STYLE	
MM/IN	DATE
DRAWN BY	C. YORK
DATE	2006/08/11
CHECKED BY	J. MACNEIL
DATE	2006/08/11
APPROVED BY	R. DEROSS
DATE	2006/08/11

SCALE	DESIGN UNITS	THIRD ANGLE PROJECTION
2:1	INCH	☉
TITLE 9.53 [0.375] DOUBLE ROW LOW PROFILE BTS ASSY		
MATERIAL NO. SEE SHT. 2		
DOCUMENT NO. SD-38770-004		SHEET NO. 1 OF 2
MATERIAL NO. THIS DRAWING CONTAINS INFORMATION THAT IS PROPRIETARY TO MOLEX INCORPORATED AND SHOULD NOT BE USED WITHOUT WRITTEN PERMISSION		

NO. OF CIRCUITS	DIM. "A"		DIM. "B"		DIM. "C"		DIM. "D"		ASSEMBLY MATERIAL NO. (STANDARD)	ASSEMBLY MATERIAL NO. (-49 OPTION)	ASSEMBLY MATERIAL NO. (-50 OPTION)	ASSEMBLY MATERIAL NO. (-58 OPTION)	ASSEMBLY MATERIAL NO. (-10A OPTION)	ASSEMBLY MATERIAL NO. (-61 OPTION)
	mm	in	mm	in	mm	in	mm	in						
02	35.7	1.41	9.53	0.375	28.58	1.125	21.3	0.84	38770-0102	38770-0202	38770-0302	38770-0402	38770-0502	38770-0602
03	45.2	1.78	19.05	0.750	38.10	1.500	30.8	1.21	38770-0103	38770-0203	38770-0303	38770-0403	38770-0503	38770-0603
04	54.7	2.16	28.58	1.125	47.63	1.875	40.3	1.59	38770-0104	38770-0204	38770-0304	38770-0404	38770-0504	38770-0604
05	64.3	2.53	38.10	1.500	57.15	2.250	49.8	1.96	38770-0105	38770-0205	38770-0305	38770-0405	38770-0505	38770-0605
06	73.8	2.91	47.63	1.875	66.68	2.625	59.4	2.34	38770-0106	38770-0206	38770-0306	38770-0406	38770-0506	38770-0606
07	83.3	3.28	57.15	2.250	76.20	3.000	68.9	2.71	38770-0107	38770-0207	38770-0307	38770-0407	38770-0507	38770-0607
08	92.8	3.66	66.68	2.625	85.73	3.375	78.4	3.09	38770-0108	38770-0208	38770-0308	38770-0408	38770-0508	38770-0608
09	102.4	4.03	76.20	3.000	95.25	3.750	87.9	3.46	38770-0109	38770-0209	38770-0309	38770-0409	38770-0509	38770-0609
10	111.9	4.41	85.73	3.375	104.78	4.125	97.5	3.84	38770-0110	38770-0210	38770-0310	38770-0410	38770-0510	38770-0610
11	121.4	4.78	95.25	3.750	114.30	4.500	107.0	4.21	38770-0111	38770-0211	38770-0311	38770-0411	38770-0511	38770-0611
12	130.9	5.16	104.78	4.125	123.83	4.875	116.5	4.59	38770-0112	38770-0212	38770-0312	38770-0412	38770-0512	38770-0612
13	140.5	5.53	114.30	4.500	133.35	5.250	126.0	4.96	38770-0113	38770-0213	38770-0313	38770-0413	38770-0513	38770-0613
14	150.0	5.91	123.83	4.875	142.88	5.625	135.6	5.34	38770-0114	38770-0214	38770-0314	38770-0414	38770-0514	38770-0614
15	159.5	6.28	133.35	5.250	152.40	6.000	145.1	5.71	38770-0115	38770-0215	38770-0315	38770-0415	38770-0515	38770-0615
16	169.0	6.66	142.88	5.625	161.93	6.375	154.6	6.09	38770-0116	38770-0216	38770-0316	38770-0416	38770-0516	38770-0616
17	178.6	7.03	152.40	6.000	171.45	6.750	164.1	6.46	38770-0117	38770-0217	38770-0317	38770-0417	38770-0517	38770-0617
18	188.1	7.41	161.93	6.375	180.89	7.125	173.7	6.84	38770-0118	38770-0218	38770-0318	38770-0418	38770-0518	38770-0618
19	197.6	7.78	171.45	6.750	190.50	7.500	183.2	7.21	38770-0119	38770-0219	38770-0319	38770-0419	38770-0519	38770-0619
20	207.1	8.16	180.89	7.125	200.03	7.875	192.7	7.59	38770-0120	38770-0220	38770-0320	38770-0420	38770-0520	38770-0620
21	216.7	8.53	190.50	7.500	209.55	8.250	202.2	7.96	38770-0121	38770-0221	38770-0321	38770-0421	38770-0521	38770-0621
22	226.2	8.91	200.03	7.875	219.08	8.625	211.8	8.34	38770-0122	38770-0222	38770-0322	38770-0422	38770-0522	38770-0622
23	235.7	9.28	209.55	8.250	228.60	9.000	221.3	8.71	38770-0123	38770-0223	38770-0323	38770-0423	38770-0523	38770-0623
24	245.2	9.66	219.08	8.625	238.13	9.375	230.8	9.09	38770-0124	38770-0224	38770-0324	38770-0424	38770-0524	38770-0624
25	254.8	10.03	228.60	9.000	247.65	9.750	240.3	9.46	38770-0125	38770-0225	38770-0325	38770-0425	38770-0525	38770-0625
26	264.3	10.41	238.13	9.375	257.18	10.125	249.9	9.84	38770-0126	38770-0226	38770-0326	38770-0426	38770-0526	38770-0626
27	273.8	10.78	247.65	9.750	266.70	10.500	259.4	10.21	38770-0127	38770-0227	38770-0327	38770-0427	38770-0527	38770-0627
28	283.3	11.16	257.18	10.125	276.23	10.875	268.9	10.59	38770-0128	38770-0228	38770-0328	38770-0428	38770-0528	38770-0628
29	292.9	11.53	266.70	10.500	285.75	11.250	278.4	10.96	38770-0129	38770-0229	38770-0329	38770-0429	38770-0529	38770-0629
30	302.4	11.91	276.23	10.875	295.28	11.625	288.0	11.34	38770-0130	38770-0230	38770-0330	38770-0430	38770-0530	38770-0630

(B)

SEE SHEET 1 EC NO: IPG2014-1260 DRAWN: ENC JMS 2013/10/14 CHKD: JMACNEIL 2014/02/07 APPR: JMACNEIL 2014/03/10	QUALITY SYMBOLS ▽=0 ▽=0	GENERAL TOLERANCES (UNLESS SPECIFIED)		DIMENSION STYLE MM/IN		SCALE 2:1	DESIGN UNITS INCH	THIRD ANGLE PROJECTION
		4 PLACES ± --- ± --- 3 PLACES ± --- ± .005 2 PLACES ± 0.13 ± .01 1 PLACE ± 0.3 ± ---	mm INCH	DRAWN BY DATE C. YORK 2006/08/11	TITLE 9.53 [.375] DOUBLE ROW LOW PROFILE BTS ASSY			
		DRAFT WHERE APPLICABLE MUST REMAIN WITHIN DIMENSIONS		APPROVED BY DATE R. DEROSS 2006/08/11	MOLEX INCORPORATED			
				MATERIAL NO. SEE CHART	DOCUMENT NO. SD-38770-004	SHEET NO. 2 OF 2		

Mouser Electronics

Authorized Distributor

Click to View Pricing, Inventory, Delivery & Lifecycle Information:

Molex:

[38770-0102](#) [38770-0104](#) [38770-0105](#) [38770-0106](#) [38770-0107](#) [38770-0108](#) [38770-0110](#) [38770-0112](#) [38770-0116](#) [38770-0120](#) [38770-0305](#) [38770-0306](#) [38770-1105](#) [38770-1111](#) [38770-0124](#) [38770-0308](#) [38770-0304](#) [38770-0307](#) [38770-0302](#) [38770-0303](#) [38770-0310](#) [38770-0109](#) [38770-0114](#) [38770-0115](#) [38770-0111](#) [38770-3207](#) [38770-0209](#) [38770-0207](#) [38770-0203](#) [38770-0204](#) [38770-0206](#) [38770-0103](#) [38770-0212](#) [38770-2606](#) [38770-0130](#) [38770-0113](#) [38770-0118](#) [38770-0122](#) [38770-1706](#) [38770-1512](#) [38770-0320](#) [38770-0702](#) [38770-1103](#) [38770-1102](#) [38770-1104](#) [38770-3422](#) [38770-0605](#) [38770-0314](#) [38770-1506](#) [38770-0503](#) [38770-1715](#) [38770-3304](#) [38770-3306](#) [38770-0806](#) [38770-0324](#) [38770-3320](#) [38770-1514](#) [38770-0101](#) [38770-0117](#) [38770-0119](#) [38770-0121](#) [38770-0123](#) [38770-0125](#) [38770-0126](#) [38770-0127](#) [38770-0128](#) [38770-0129](#) [38770-0202](#) [38770-0205](#) [38770-0208](#) [38770-0210](#) [38770-0211](#) [38770-0213](#) [38770-0214](#) [38770-0215](#) [38770-0216](#) [38770-0217](#) [38770-0218](#) [38770-0219](#) [38770-0220](#) [38770-0222](#) [38770-0224](#) [38770-0225](#) [38770-0226](#) [38770-0228](#) [38770-0229](#) [38770-0230](#) [38770-0309](#) [38770-0311](#) [38770-0312](#) [38770-0313](#) [38770-0315](#) [38770-0316](#) [38770-0317](#) [38770-0318](#) [38770-0321](#) [38770-0322](#) [38770-0325](#) [38770-0327](#) [38770-0328](#)