

- NOTES:**
- PART DESIGNED IN METRIC.
  - TERMINAL FOR USE WITH 5557 SERIES HOUSINGS.
  - MATES WITH 5558, 5566 AND 5569 SERIES CONNECTORS.
  - REFER TO DWG. NO. CS-5556\*/5558\* FOR CRIMP SPECIFICATIONS.
  - PRODUCT SPECIFICATION AND PROCESSING PARAMETERS SEE: PS-5556-001, PS-5556-002, PS-5556-003

- MATERIAL:**
- CDA 260 BRASS, .0080±.0004/(0.203±0.010) THICK.
  - CDA 510 PHOS. BRONZE .0080±.0004/(0.203±0.010) THICK.

- PLATING:**
- \*A. SELECTIVE GOLD PLATE .000030/(0.00076) MIN., AND SELECTIVE MATTE TIN .000100/(0.00254) OVER .000050/(0.00127) NICKEL OVERALL.
  - \*B. SELECTIVE GOLD PLATE .000015/(0.00038) MIN., AND SELECTIVE MATTE TIN .000100/(0.00254) OVER .000050/(0.00127) NICKEL OVERALL.
  - \*C. SELECTIVE GOLD PLATE .000050/(0.00127) MIN., AND SELECTIVE MATTE TIN .000100/(0.00254) OVER .000050/(0.00127) NICKEL OVERALL.
  - \*THE PRIMARY SHIPPING CARTON WILL BE LABELED "COMPLIANT TO RoHS DIRECTIVE 2002/95/EC AND ELV ANNEX II OF DIRECTIVE 2000/53/EC." CARTONS WITHOUT THIS LABEL MAY CONTAIN PRODUCT WITH TIN-LEAD PLATING.

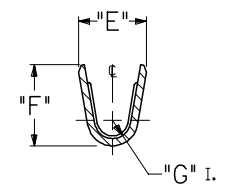
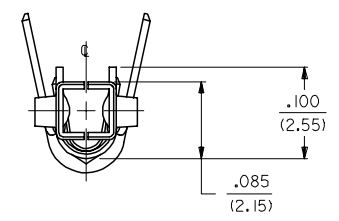
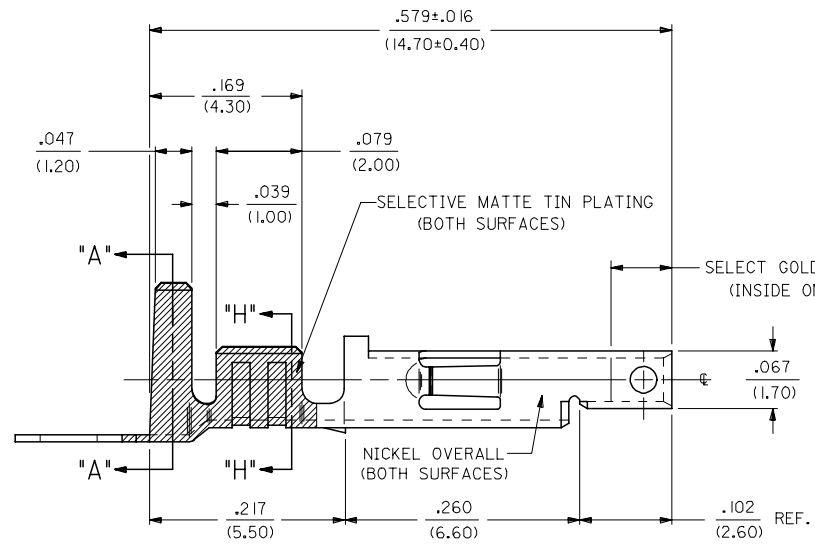

SECT. "H-H"

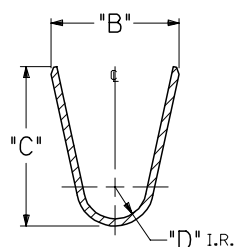

SECT. "A-A"

REMOVE 28-30 GAGE EC NO: UCP2006-1559 DRAWNDONE 2006/01/11 CHKD: GPOLGAR 2006/01/12 APPR: ICOMERCI 2006/01/16	QUALITY SYMBOLS =0 =0 R.	GENERAL TOLERANCES (UNLESS SPECIFIED)		DIMENSION STYLE IN/MM		SCALE 10:1	DESIGN UNITS METRIC	THIRD ANGLE PROJECTION			
		4 PLACES ± --- ± ---	mm INCH	DRAWN BY GEP	DATE 5/17/90	TITLE TERMINAL, MINI-FIT JR., FEMAE CRIMP, SELECT GOLD BLANK PLATE FORM					
		3 PLACES ± --- ± .010		CHECKED BY RJF	DATE 5/17/90	Molex MOLEX INCORPORATED					
		2 PLACES ± 0.25 ± .014		APPROVED BY RAS	DATE 5/17/90	MATERIAL NO. SEE SHT. 2	DOCUMENT NO. SD-5556-GSP*	SHEET NO. 1 OF 2			
1 PLACE ± 0.36 ± ---		ANGULAR ±1/2°		DRAFT WHERE APPLICABLE MUST REMAIN WITHIN DIMENSIONS		THIS DRAWING CONTAINS INFORMATION THAT IS PROPRIETARY TO MOLEX INCORPORATED AND SHOULD NOT BE USED WITHOUT WRITTEN PERMISSION					

2	F1
1	F1
SHT.	REV.

	13	12	11	10	9	8	7	6	5	5556	4	3	2	1								
	PART NO.	ENG. NO.	MAT'L.	PLATE	WIRE GAGE	QUANTITY PER REEL	DIM. "B"	DIM. "C"	DIM. "D"	DIM. "E"	DIM. "F"	DIM. "G"										
J	39-00-0163	5556-GSP	A	A	18-24 GA.	4,000	.142±.012	.177±.016	.035	.075±.012	.091±.016	.020	<b>LEGEND:</b> 5556-***GS*P* BASE NO. _____ MATERIAL _____ BLANK= BRASS PB= PHOS. BRONZE GOLD, SELECT _____ PLATING & CRIMP SIZE COMB. _____ BLANK THRU I5 BLANK-PLATE-FORM VERSION _____ CHAIN OR LOOSE _____ BLANK= CHAIN L= LOOSE									
	39-00-0164	5556-GSPL					(3.60±0.30)	(4.50±0.40)	(0.90)	(1.90±0.30)	(2.40±0.40)	(0.50)										
39-00-0165	5556-GS2P	22-28 GA.			6,000	.091±.016	.091±.016	.024	.071±.012	.065±.016	.016											
39-00-0166	5556-GS2PL					(2.30±0.30)	(2.30±0.40)	(0.60)	(1.80±0.30)	(1.65±0.40)	(0.40)											
I	39-00-0167	5556-GS3P			A	A	16 GA.	4,000	.142±.012	.177±.016	.035	.091±.012			.106±.016	.024						
	39-00-0168	5556-GS3PL							(3.60±0.30)	(4.50±0.40)	(0.90)	(2.30±0.30)			(2.70±0.40)	(0.60)						
NOT TOOLED	5556-GS10P	14 GA.					4,000	.142±.012	.177±.016	.035	.091±.012	.114±.016			.024							
NOT TOOLED	5556-GS10PL							(3.60±0.30)	(4.50±0.40)	(0.90)	(2.30±0.30)	(2.90±0.40)			(0.60)							
H	39-00-0169	5556-GS4P					A	B	18-24 GA.	4,000	.142±.012	.177±.016			.035	.075±.012			.091±.016	.020		
	39-00-0170	5556-GS4PL									(3.60±0.30)	(4.50±0.40)			(0.90)	(1.90±0.30)			(2.40±0.40)	(0.50)		
	39-00-0171	5556-GS5P	22-28 GA.	6,000					.091±.012	.091±.016	.024	.071±.012	.065±.016	.016								
	39-00-0172	5556-GS5PL							(2.30±0.30)	(2.30±0.40)	(0.60)	(1.80±0.30)	(1.65±0.40)	(0.40)								
	39-00-0173	5556-GS6P	16 GA.	4,000					.142±.012	.177±.016	.035	.091±.012	.106±.016	.024								
	39-00-0174	5556-GS6PL							(3.60±0.30)	(4.50±0.40)	(0.90)	(2.30±0.30)	(2.70±0.40)	(0.60)								
	NOT TOOLED	5556-GS11P			14 GA.	4,000			.142±.012	.177±.016	.035	.091±.012	.114±.016	.024								
	NOT TOOLED	5556-GS11PL							(3.60±0.30)	(4.50±0.40)	(0.90)	(2.30±0.30)	(2.90±0.40)	(0.60)								
	G	39-00-0175	5556-GS7P	A	C	18-24 GA.			4,000	.142±.012	.177±.016	.035	.075±.012	.091±.016	.020							
		39-00-0176	5556-GS7PL							(3.60±0.30)	(4.50±0.40)	(0.90)	(1.90±0.30)	(2.40±0.40)	(0.50)							
39-00-0177		5556-GS8P	22-28 GA.			6,000	.091±.012	.091±.016	.024	.071±.012	.065±.016	.016										
39-00-0178		5556-GS8PL					(2.30±0.30)	(2.30±0.40)	(0.60)	(1.80±0.30)	(1.65±0.40)	(0.40)										
39-00-0179		5556-GS9P	16 GA.			4,000	.142±.012	.177±.016	.035	.091±.012	.106±.016	.024										
39-00-0180		5556-GS9PL					(3.60±0.30)	(4.50±0.40)	(0.90)	(2.30±0.30)	(2.70±0.40)	(0.60)										
NOT TOOLED		5556-GS12P					14 GA.	4,000	.142±.012	.177±.016	.035	.091±.012			.114±.016			.024				
NOT TOOLED		5556-GS12PL							(3.60±0.30)	(4.50±0.40)	(0.90)	(2.30±0.30)			(2.90±0.40)			(0.60)				
F		39-00-0181	5556-PBGS P			B	A	18-24 GA.	4,000	.142±.012	.177±.016	.035	.075±.012	.091±.016	.020							
		39-00-0182	5556-PBGS PL							(3.60±0.30)	(4.50±0.40)	(0.90)	(1.90±0.30)	(2.40±0.40)	(0.50)							
	39-00-0183	5556-PBGS2P	22-28 GA.	6,000	.091±.012			.091±.016	.024	.071±.012	.065±.016	.016										
	39-00-0184	5556-PBGS2PL			(2.30±0.30)			(2.30±0.40)	(0.60)	(1.80±0.30)	(1.65±0.40)	(0.40)										
	39-00-0185	5556-PBGS3P	16 GA.	4,000	.142±.012			.177±.016	.035	.091±.012	.106±.016	.024										
	39-00-0186	5556-PBGS3PL			(3.60±0.30)			(4.50±0.40)	(0.90)	(2.30±0.30)	(2.70±0.40)	(0.60)										
	NOT TOOLED	5556-PBGS10P			14 GA.			4,000	.142±.012	.177±.016	.035	.091±.012			.114±.016	.024						
	NOT TOOLED	5556-PBGS10PL							(3.60±0.30)	(4.50±0.40)	(0.90)	(2.30±0.30)			(2.90±0.40)	(0.60)						
	E	39-00-0194	5556-PBGS4P	B	B			18-24 GA.	4,000	.142±.012	.177±.016	.035	.075±.012	.091±.016	.020							
		39-00-0195	5556-PBGS4PL							(3.60±0.30)	(4.50±0.40)	(0.90)	(1.90±0.30)	(2.40±0.40)	(0.50)							
39-00-0196		5556-PBGS5P	22-28 GA.			6,000	.091±.012	.091±.016	.024	.071±.012	.065±.016	.016										
39-00-0197		5556-PBGS5PL					(2.30±0.30)	(2.30±0.40)	(0.60)	(1.80±0.30)	(1.65±0.40)	(0.40)										
39-00-0198		5556-PBGS6P	16 GA.			4,000	.142±.012	.177±.016	.035	.091±.012	.106±.016	.024										
39-00-0199		5556-PBGS6PL					(3.60±0.30)	(4.50±0.40)	(0.90)	(2.30±0.30)	(2.70±0.40)	(0.60)										
NOT TOOLED		5556-PBGS11P					14 GA.	4,000	.142±.012	.177±.016	.035	.091±.012			.114±.016			.024				
NOT TOOLED		5556-PBGS11 PL							(3.60±0.30)	(4.50±0.40)	(0.90)	(2.30±0.30)			(2.90±0.40)			(0.60)				
D		39-00-0200	5556-PBGS7P			B	C	18-24 GA.	4,000	.142±.012	.177±.016	.035	.075±.012	.091±.016	.020							
		39-00-0201	5556-PBGS7PL							(3.60±0.30)	(4.50±0.40)	(0.90)	(1.90±0.30)	(2.40±0.40)	(0.50)							
	39-00-0202	5556-PBGS8P	22-28 GA.	6,000	.091±.012			.091±.016	.024	.071±.012	.065±.016	.016										
	39-00-0203	5556-PBGS8PL			(2.30±0.30)			(2.30±0.40)	(0.60)	(1.80±0.30)	(1.65±0.40)	(0.40)										
	39-00-0204	5556-PBGS9P	16 GA.	4,000	.142±.012			.177±.016	.035	.091±.012	.106±.016	.024										
	39-00-0205	5556-PBGS9PL			(3.60±0.30)			(4.50±0.40)	(0.90)	(2.30±0.30)	(2.70±0.40)	(0.60)										
	NOT TOOLED	5556-PBGS12P			14 GA.			4,000	.142±.012	.177±.016	.035	.091±.012			.114±.016	.024						
	NOT TOOLED	5556-PBGS12PL							(3.60±0.30)	(4.50±0.40)	(0.90)	(2.30±0.30)			(2.90±0.40)	(0.60)						

SEE SHEET 1 EC NO: UCP2006-1559 DRAWNDUNNE 2006/01/11 CHKD: GPOL GAR 2006/01/12 APPR: ICOMERC L 2006/01/16 DESCRIPTION	QUALITY SYMBOLS ▽=0 ▽=0	GENERAL TOLERANCES (UNLESS SPECIFIED) mm INCH 4 PLACES ± --- ± --- 3 PLACES ± --- ± --- 2 PLACES ± --- ± --- 1 PLACE ± --- ± --- ANGULAR ±1/2°	DIMENSION STYLE IN/MM DRAWN BY DATE GEP 5/17/90 CHECKED BY DATE RJF 5/17/90 APPROVED BY DATE RAS 5/17/90	SCALE --- DESIGN UNITS METRIC THIRD ANGLE PROJECTION	TITLE TERMINAL, MINI-FIT JR., FEMALE, CRIMP, SELECT GOLD BLANK-PLATE-FORM MOLEX MOLEX INCORPORATED
	DRAFT WHERE APPLICABLE MUST REMAIN WITHIN DIMENSIONS	MATERIAL NO. SEE CHART	DOCUMENT NO. SD-5556-GSP*	SHEET NO. 2 2	