

Distributed by:

JAMECO[®]
ELECTRONICS

www.Jameco.com ♦ 1-800-831-4242

The content and copyrights of the attached
material are the property of its owner.

Jameco Part Number 303829

FEATURES AND SPECIFICATIONS

Features and Benefits

- Wire-to-wire plug for panel-mounted or free-hanging applications
- Available with and without panel mounting ears
- Positive housing locks to mate with Mini-Fit, Jr. receptacle
- Fully isolated terminals to protect contacts from damage
- Uses standard Mini-Fit series terminals

Reference Information

Product Specification: PS-5556-0001
 Packaging: Tray or bag
 UL File No.: E29179
 CSA File No.: LR19980
 TUV License No.: R75142
 Mates With: [5557](#) single row receptacle
 Use With: [5558](#), [30490](#) or 44478 terminals
 Designed In: Millimeters

Mechanical

Contact Insertion Force: 1.5kg max.
 Contact Retention to Housing: 3.0kg min.
 Wire Pull-Out Force: 9.0kg min.
 Insertion Force to PCB: 5.0kg max.
 Mating Force: 0.7kg (1.54 lb) max.
 Unmating Force: 0.35kg (0.7 lb) min.
 Normal Force: 200g min.
 Durability: 30 cycles

Physical

Housing: 6/6 nylon, UL 94V-2 or 94V-0
 Contact: Brass or Phosphor Bronze
 Plating: Tin, select Gold or overall Gold
 Operating Temperature: -40 to +105°C

molex® 4.20mm (.165") Pitch Mini-Fit, Jr.™ Plug

5559

Single Row, With and Without Panel Mount Ears

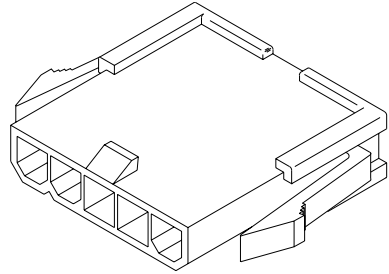

CATALOG DRAWING (FOR REFERENCE ONLY)

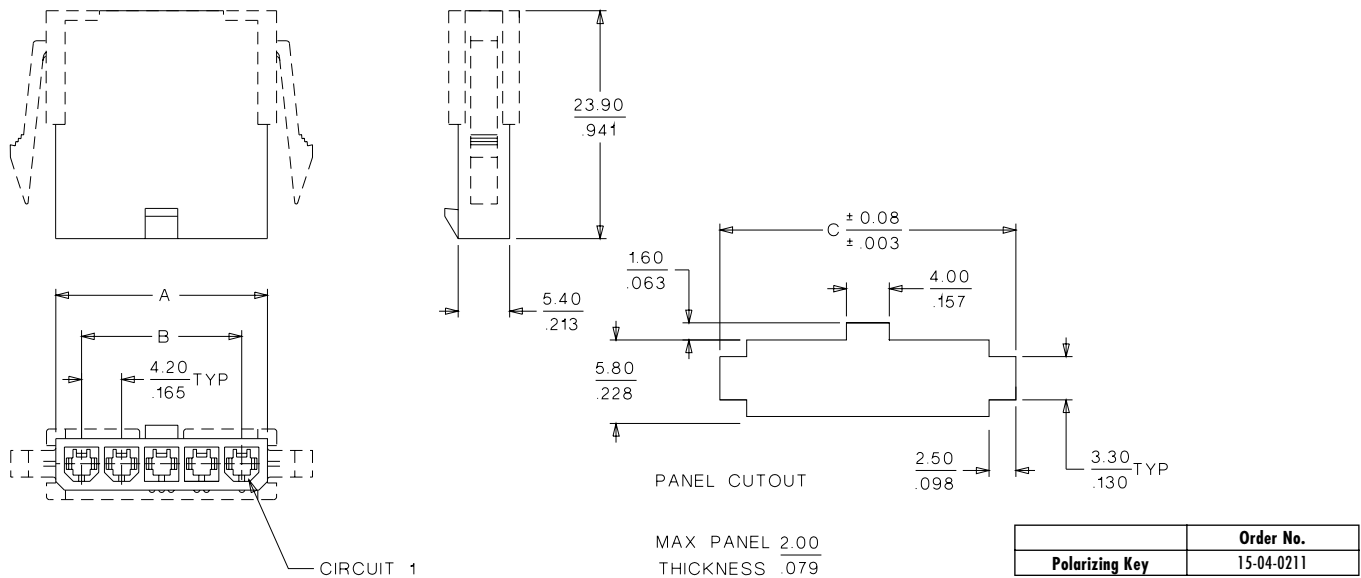

ORDERING INFORMATION AND DIMENSIONS

Circuits	Order No.				Dimension		
	Panel Mount		Free Hanging		A	B	C
	94V-2	94V-0	94V-2	94V-0			
3*	• 39-01-4032	• 39-01-4033	• 39-01-4036	• 39-01-4037	13.80 (.543)	8.40 (.331)	19.20 (.756)
4			• 39-01-4046		18.00 (.709)	12.60 (.496)	23.40 (.921)
5	• 39-01-4052	• 39-01-4053	• 39-01-4056	• 39-01-4057	22.20 (.847)	16.80 (.661)	27.60 (1.087)

* US Standard Product, available through Molex franchised distributors

* 3-circuit plug designed for first-mate/last-break applications



PRODUCT SPECIFICATION

MINI-FIT JR.

1.0 SCOPE

This Product Specification covers performance requirements for the MINI-FIT JR. 4.20 mm (.165 inch) centerline (pitch) printed circuit board (PCB) connector series with Tin or Gold plating, and The MINI-FIT JR. connector series terminated with 16 to 28 AWG wire using Crimp technology with Tin or Gold plating.

2.0 PRODUCT DESCRIPTION

2.1 PRODUCT NAME AND SERIES NUMBER (S)

<u>PRODUCT NAME</u>	<u>PART NUMBER</u>
Female Crimp Terminal	5556-****
Male Crimp Terminal	5558-****
Receptacle Housing	5557-****
Plug Housing	5559-****
Vertical Header Assembly	5566-****
Right Angle Header Assembly	5569-****

2.2 DIMENSIONS, MATERIALS, PLATINGS AND MARKINGS

See the appropriate sales drawings for the information on dimensions, materials, platings and markings.

2.3 SAFETY AGENCY APPROVALS

UL File: E29179
CSA Certificate: LR 19980
TUV Certificate: R75142-8

3.0 APPLICABLE DOCUMENTS AND SPECIFICATIONS

See sales drawings and the other sections of this specification for the necessary referenced documents and specifications

4.0 RATINGS

4.1 VOLTAGE

600 Volts AC (RMS) (or 600 Volts DC)

4.2 CURRENT AND APPLICABLE WIRES

Maximum Insulation Diameter and Applicable Wire Gauges	16 AWG: 3.10/. 122 MAXIMUM
	18-24 AWG: 3.10/. 122 MAXIMUM
	22-28 AWG: 1.80/. 071 MAXIMUM

<u>REVISION:</u> C	<u>EGR/ECN INFORMATION:</u> EC No: UCP2004-2349 DATE: 2004 / 05 / 25	<u>TITLE:</u> PRODUCT SPECIFICATION FOR MINI-FIT JR. CONNECTOR SYSTEM	<u>SHEET No.</u> 1 of 5
<u>DOCUMENT NUMBER:</u> PS-5556-001	<u>CREATED / REVISED BY:</u> BANDURA	<u>CHECKED BY:</u> BANDURA	<u>APPROVED BY:</u> MARGULIS



PRODUCT SPECIFICATION

4.2 CURRENT AND APPLICABLE WIRES (continued)

MAXIMUM CURRENT RATING (Amperes)									
Brass					Phosphor Bronze				
Wire \ Ckt. Size	2 & 3	4 - 6	7 - 10	12 - 24	Wire \ Ckt. Size	2 & 3	4 - 6	7 - 10	12 - 24
AWG #16	9	8	7	6	AWG #16	8	7	6	5
AWG #18	9	8	7	6	AWG #18	8	7	6	5
AWG #20	7	6	5	5	AWG #20	6	5	4	4
AWG #22	5	4	4	4	AWG #22	4	3	3	3
AWG #24	4	3	3	3	AWG #24	3	2	2	2
AWG #26	3	2	2	2	AWG #26	2	1	1	1
AWG #28	2	1	1	1	AWG #28	1	1	1	1

4.3 TEMPERATURE

Operating: * - 40°C to + 105°C

Nonoperating: - 40°C to + 105°C

*Including 30°C terminal temperature at rated current

5.0 PERFORMANCE

5.1 ELECTRICAL REQUIREMENTS

ITEM	DESCRIPTION	TEST CONDITION	REQUIREMENT
1	Contact Resistance (Low Level)	Mate connectors: apply a maximum voltage of 20 mV and a current of 100 mA. Wire resistance shall be removed from the measured value.	10 milliohms MAXIMUM [initial]
2	Contact Resistance @ Rated Current	Mate connectors: apply a maximum voltage of 20 mV at rated current.	10 milliohms MAXIMUM [initial]
3	Contact Resistance of Wire Termination (Low Level)	Terminate the applicable wire to the terminal and measure wire using a voltage of 20 mV and a current of 100 mA.	5 milliohms MAXIMUM [initial]
4	Insulation Resistance	Mate connectors: apply a voltage of 500 VDC between adjacent terminals and between terminals to ground.	1000 Megohms MINIMUM

REVISION: C	EGR/ECN INFORMATION: EC No: UCP2004-2349 DATE: 2004 / 05 / 25	TITLE: PRODUCT SPECIFICATION FOR MINI-FIT JR. CONNECTOR SYSTEM	SHEET No. 2 of 5
DOCUMENT NUMBER: PS-5556-001		CREATED / REVISED BY: BANDURA	CHECKED BY: BANDURA
		APPROVED BY: MARGULIS	



PRODUCT SPECIFICATION

5.1 ELECTRICAL REQUIREMENTS (continued)

ITEM	DESCRIPTION	TEST CONDITION	REQUIREMENT
5	Dielectric Withstanding Voltage	Mate connectors: apply a voltage of 1500 VAC for 1 minute between adjacent terminals and between terminals to ground.	No breakdown. Current leakage < 5 mA
6	Temperature Rise (via Current Cycling)	Mate connectors. Measure the temperature rise at the rated current after 96 hours, during current cycling (45 minutes ON and 15 minutes OFF per hour) for 240 hours, and after final 96-hour steady state.	Temperature rise: +30°C MAXIMUM

5.2 MECHANICAL REQUIREMENTS

ITEM	DESCRIPTION	TEST CONDITION	REQUIREMENT
1	Terminal Insertion and Withdrawal Forces	Insert and withdraw terminal (male to female) at a rate of 25 ± 6 mm (1 ± ¼ inch) per minute.	14.7 N (3.30 lbf) MAXIMUM insertion force & 1.0 N (0.02 lbf) MINIMUM withdrawal force
2	Terminal Retention Force (in Housing)	Axial pullout force on the terminal in the housing at a rate of 25 ± 6 mm (1 ± ¼ inch) per minute.	30 N (6.74 lbf) MINIMUM retention force
3	Durability	Mate connectors up to 30 cycles at a maximum rate of 10 cycles per minute prior to Environmental Tests.	20 milliohms MAXIMUM
4	Vibration (Random)	Mate connectors and vibrate per EIA 364-28, test condition VII.	10 milliohms MAXIMUM (change from initial) & Discontinuity < 1 microsecond
5	Shock (Mechanical)	Mate connectors and shock at 50 g's with ½ sine wave (11 milliseconds) shocks in the ±X, ±Y, ±Z axes, (18 shocks total).	20 milliohms MAXIMUM & Discontinuity < 1 microsecond
6	Wire Pullout Force (Axial)	Apply an axial pullout force on the wire at a rate of 25 ± 6 mm (1 ± ¼ inch).	16 Awg = 88.0 N (19.8 lbf) Min. 18 Awg = 88.0 N (19.8 lbf) Min. 20 Awg = 59.0 N (13.3 lbf) Min. 22 Awg = 39.0 N (8.78 lbf) Min. 24 Awg = 29.0 N (6.52 lbf) Min. 26 Awg = 19.0 N (4.27 lbf) Min. 28 Awg = 9.80 N (2.20 lbf) Min.

<u>REVISION:</u> C	<u>EGR/ECN INFORMATION:</u> EC No: UCP2004-2349 DATE: 2004 / 05 / 25	<u>TITLE:</u> PRODUCT SPECIFICATION FOR MINI-FIT JR. CONNECTOR SYSTEM	<u>SHEET No.</u> 3 of 5
<u>DOCUMENT NUMBER:</u> PS-5556-001	<u>CREATED / REVISED BY:</u> BANDURA	<u>CHECKED BY:</u> BANDURA	<u>APPROVED BY:</u> MARGULIS



PRODUCT SPECIFICATION

5.2 MECHANICAL REQUIREMENTS (continued)

7	Terminal Insertion Force (into Housing)	Apply an axial insertion force on the terminal at a rate of 25 ± 6 mm ($1 \pm \frac{1}{4}$ inch).	15.0 N (3.37 lbf) MAXIMUM insertion force
8	Normal Force	Apply a perpendicular force.	0.49 N (50 grams) MINIMUM [Gold (noble) plating] OR 1.47 N (150 grams) MINIMUM [Tin (non-noble) plating]
9	PCB Engagement and Separation Forces	Engage and separate a connector at a rate of 25 ± 6 mm ($1 \pm \frac{1}{4}$ inch) per minute. (Applies to parts with PCB retention features only)	49.0 N (11.0 lbf) MAXIMUM insertion force & 10.0 N (2.24 lbf) MINIMUM withdrawal force
10	Panel Insertion and Withdrawal Forces	Insert and withdraw a connector at a rate of 25 ± 6 mm ($1 \pm \frac{1}{4}$ inch) per minute. (Applies to parts with panel retention features only)	225 N (50.7 lbf) MAXIMUM insertion force & 157 N (35.3 lbf) MINIMUM withdrawal force
11	Pin Retention Force	Apply axial push force at the speed rate of 25 ± 3 mm/minute.	1.0 KGF MIN.
12	Thumb latch Operation Force	Depress latch at a speed rate of 25.4 mm/minute.	1.7 KGF MAX.
13	Thumb latch Yield Strength	Mate loaded connectors fully. Pull apart via wires at a speed rate of 25.4 mm/minute.	7.0 KGF MIN.

<u>REVISION:</u> C	<u>EGR/ECN INFORMATION:</u> EC No: UCP2004-2349 DATE: 2004 / 05 / 25	<u>TITLE:</u> PRODUCT SPECIFICATION FOR MINI-FIT JR. CONNECTOR SYSTEM	<u>SHEET No.</u> 4 of 5
<u>DOCUMENT NUMBER:</u> PS-5556-001	<u>CREATED / REVISED BY:</u> BANDURA	<u>CHECKED BY:</u> BANDURA	<u>APPROVED BY:</u> MARGULIS



PRODUCT SPECIFICATION

5.3 ENVIRONMENTAL REQUIREMENTS (continued)

ITEM	DESCRIPTION	TEST CONDITION	REQUIREMENT
1	Thermal Shock	Mate connectors: expose for 5 cycles Between temperatures -55 and 105° C; Dwell 0.5 hours at each temperature.	20 milliohms MAXIMUM Visual: No Damage Dielectric Strength per 5.1.5 Insulation Resistance per 5.1.4
2	Thermal Aging	Mate connectors; expose to: 96 hours at 105 ± 2°C	20 milliohms MAXIMUM & Visual: No Damage
3	Humidity (Steady State)	Mate connectors: expose to a temperature of 60 ± 2°C with a relative humidity of 90-95% for 96 hours.	20 milliohms MAXIMUM Dielectric Strength per 5.1.5 Insulation Resistance per 5.1.4 Visual: No Damage
4	Solderability	Per SMES-152	Solder coverage: 95% MINIMUM (per SMES-152)
5	Solder Resistance	Dip connector terminals tail in solder: Solder Duration: 5 ± 0.5 seconds; Solder Temperature: 260 ± 5°C	Visual: No Damage to insulator material
6	Cold Resistance	Mate connectors: Duration; 96 hours; Temperature: -40 ± 3°C	20 milliohms MAXIMUM Visual: No Damage
7	Corrosive Atmosphere: Sulfur Dioxide Gas (SO₂)	Mate connectors: Duration; 24 hours exposure. Atmosphere: 50 parts per million (ppm) SO ₂ Gas. Temperature: 40 ± 3°C	20 milliohms MAXIMUM Visual: No Damage

6.0 PACKAGING

Parts shall be packaged to protect against damage during handling, transit and storage.

REVISION: C	EGR/ECN INFORMATION: EC No: UCP2004-2349 DATE: 2004 / 05 / 25	TITLE: PRODUCT SPECIFICATION FOR MINI-FIT JR. CONNECTOR SYSTEM	SHEET No. 5 of 5
DOCUMENT NUMBER: PS-5556-001	CREATED / REVISED BY: BANDURA	CHECKED BY: BANDURA	APPROVED BY: MARGULIS



PRODUCT SPECIFICATION

<u>REVISION:</u> C	<u>EGR/ECN INFORMATION:</u> <u>EC No:</u> UCP2004-2349 <u>DATE:</u> 2004 / 05 / 25	<u>TITLE:</u> PRODUCT SPECIFICATION FOR MINI-FIT JR. CONNECTOR SYSTEM	<u>SHEET No.</u> 6 of 5
<u>DOCUMENT NUMBER:</u> PS-5556-001	<u>CREATED / REVISED BY:</u> BANDURA	<u>CHECKED BY:</u> BANDURA	<u>APPROVED BY:</u> MARGULIS



PRODUCT SPECIFICATION

REVISION: C	EGR/ECN INFORMATION: EC No: UCP2004-2349 DATE: 2004 / 05 / 25	TITLE: PRODUCT SPECIFICATION FOR MINI-FIT JR. CONNECTOR SYSTEM	SHEET No. 7 of 5
DOCUMENT NUMBER: PS-5556-001	CREATED / REVISED BY: BANDURA	CHECKED BY: BANDURA	APPROVED BY: MARGULIS

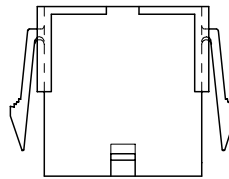
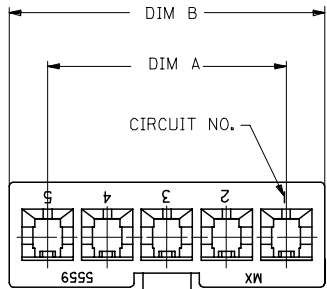

WITH MOUNTING EARS

CKT SIZE	DIM A	DIM B	DIM C	DIM D
4	.496 (12.60)	.709 (18.00)	.724 (18.40)	.921 (23.40)
5	.661 (16.80)	.874 (22.20)	.890 (22.60)	1.087 (27.60)
6	.827 (21.00)	1.039 (26.40)	1.055 (26.80)	1.252 (31.80)
7	.992 (25.20)	1.205 (30.60)	1.220 (31.00)	1.417 (36.00)
8	1.157 (29.40)	1.370 (34.80)	1.386 (35.20)	1.583 (40.20)
9	1.323 (33.60)	1.535 (39.00)	1.551 (39.40)	1.748 (44.40)
10	1.488 (37.80)	1.701 (43.20)	1.717 (43.60)	1.913 (48.60)
11	1.654 (42.00)	1.866 (47.40)	1.882 (47.80)	2.079 (52.80)
12	1.819 (46.20)	2.031 (51.60)	2.047 (52.00)	2.244 (57.00)

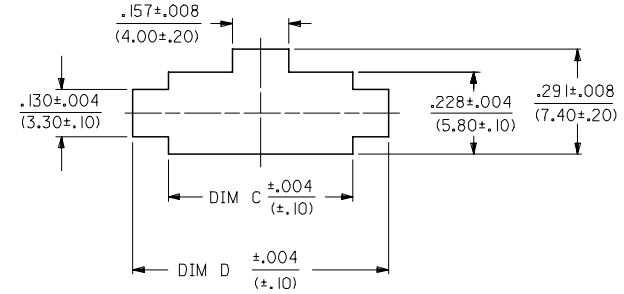
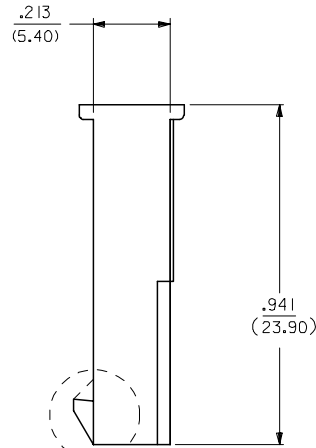
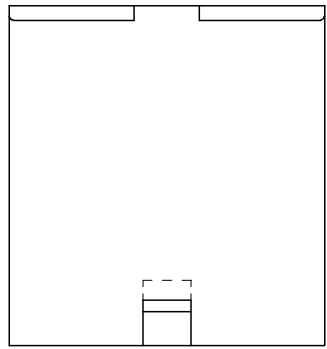

RECOMMENDED PANEL CUT-OUT
(SEE NOTES 5 & 6)

NOTES:

- MATERIAL; BLANK=NYLON 6/6, UL 94V-2, COLOR: NATURAL.
210=NYLON 6/6, UL 94V-0, COLOR: NATURAL.
210-BL= NYLON 6/6, UL 94V-0 COLOR: BLACK.
- THIS PART MATES WITH RECEPTACLE NO 5557.
- PART IS DESIGNED IN METRIC.
- THIS PART IS FOR USE WITH MOLEX MALE TERMINAL NO. 5558-*
- PANEL MOUNT VERSION IS FOR USE WITH .031/.079/(0.80/2.00) THICK PANELS.
- PANEL SHOULD BE PUNCHED IN THE DIRECTION OF CONNECTOR INSERTION.
- PRODUCT SPECIFICATION: PS-5556-001

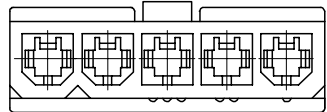

WITHOUT MOUNTING EARS

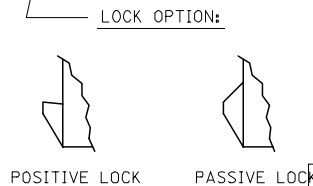

ADDED 50-30-4446 EC NO: UCP2006-0276 DRAWNDUNNE 2005/08/09 CHKD:GPOUGAR 2005/08/09 APPR: ICOMERC.L 2005/08/11	QUALITY SYMBOLS ▽=0 ▽=0
---	-------------------------------

GENERAL TOLERANCES (UNLESS SPECIFIED)	
4 PLACES ±.005	±.010
3 PLACES ±.005	±.010
2 PLACES ±.025	±.015
1 PLACE ±0.38	±.015
ANGULAR ±1/2°	

DIMENSION STYLE	
IN/MM	
DRAWN BY	DATE
KSS	2/19/89
CHECKED BY	DATE
RJF	2/19/89
APPROVED BY	DATE
RAS	2/19/89
MATERIAL NO.	DOCUMENT NO.
SEE CHART	SD-5559-NLP*

SCALE ---	DESIGN UNITS METRIC	THIRD ANGLE PROJECTION
MINI-FIT JR. SERIES PLUG (SINGLE ROW)		
MOLEX INCORPORATED		
MATERIAL NO. SEE CHART		SHEET NO. 1 OF 2
THIS DRAWING CONTAINS INFORMATION THAT IS PROPRIETARY TO MOLEX INCORPORATED AND SHOULD NOT BE USED WITHOUT WRITTEN PERMISSION		

13	12	11	10	9	8	
PART NO	ENG NO	CKT SIZE	MOUNTING OPTION	LOCK OPTION	MATERIAL SEE NOTE I	
J	39-01-4042	5559-04P2	4	W/EARS	POSITIVE	94V-2
J	39-01-4046	5559-04P3	4	W/O EAR	POSITIVE	94V-2
J	39-01-4043	5559-04P2-210	4	W/EARS	POSITIVE	94V-0
J	39-01-4047	5559-04P3-210	4	W/O EAR	POSITIVE	94V-0
I	39-01-4052	5559-05P2	5	W/EARS	POSITIVE	94V-2
I	39-01-4056	5559-05P3	5	W/O EAR	POSITIVE	94V-2
I	39-01-4053	5559-05P2-210	5	W/EARS	POSITIVE	94V-0
I	39-01-4057	5559-05P3-210	5	W/O EAR	POSITIVE	94V-0
I	50-30-4446	5559-05P3-210-BL	5	W/O EAR	POSITIVE	94V-0
H	39-01-4062	5559-06P2	6	W/EARS	POSITIVE	94V-2
H	39-01-4066	5559-06P3	6	W/O EAR	POSITIVE	94V-2
H	39-01-4063	5559-06P2-210	6	W/EARS	POSITIVE	94V-0
H	39-01-4067	5559-06P3-210	6	W/O EAR	POSITIVE	94V-0
H	39-01-4072	5559-07P2	7	W/EARS	POSITIVE	94V-2
G	39-01-4076	5559-07P3	7	W/O EAR	POSITIVE	94V-2
G	39-01-4073	5559-07P2-210	7	W/EARS	POSITIVE	94V-0
G	39-01-4077	5559-07P3-210	7	W/O EAR	POSITIVE	94V-0
G	39-01-4082	5559-08P2	8	W/EARS	POSITIVE	94V-2
G	39-01-4086	5559-08P3	8	W/O EAR	POSITIVE	94V-2
G	39-01-4083	5559-08P2-210	8	W/EARS	POSITIVE	94V-0
G	39-01-4087	5559-08P3-210	8	W/O EAR	POSITIVE	94V-0
F	39-01-4092	5559-09P2	9	W/EARS	POSITIVE	94V-2
F	39-01-4096	5559-09P3	9	W/O EAR	POSITIVE	94V-2
F	39-01-4093	5559-09P2-210	9	W/EARS	POSITIVE	94V-0
F	39-01-4097	5559-09P3-210	9	W/O EAR	POSITIVE	94V-0
E	39-01-4102	5559-10P2	10	W/EARS	POSITIVE	94V-2
E	39-01-4106	5559-10P3	10	W/O EAR	POSITIVE	94V-2
E	39-01-4103	5559-10P2-210	10	W/EARS	POSITIVE	94V-0
E	39-01-4107	5559-10P3-210	10	W/O EAR	POSITIVE	94V-0
E	39-01-4112	5559-11P2	11	W/EARS	POSITIVE	94V-2
E	39-01-4116	5559-11P3	11	W/O EAR	POSITIVE	94V-2
E	39-01-4113	5559-11P2-210	11	W/EARS	POSITIVE	94V-0
D	39-01-4117	5559-11P3-210	11	W/O EAR	POSITIVE	94V-0
D	39-01-4122	5559-12P2	12	W/EARS	POSITIVE	94V-2
D	39-01-4126	5559-12P3	12	W/O EAR	POSITIVE	94V-2
D	39-01-4123	5559-12P2-210	12	W/EARS	POSITIVE	94V-0
D	39-01-4127	5559-12P3-210	12	W/O EAR	POSITIVE	94V-0

7	6	5	4	3	2	1
PART NO	ENG NO	CKT SIZE	MOUNTING OPTION	LOCK OPTION	MATERIAL SEE NOTE I	
J	NO E.D.P.	5559-04P4	4	W/EARS	PASSIVE	94V-2
J	NO E.D.P.	5559-04P5	4	W/O EAR	PASSIVE	94V-2
J	NO E.D.P.	5559-04P4-210	4	W/EARS	PASSIVE	94V-0
J	NO E.D.P.	5559-04P5-210	4	W/O EAR	PASSIVE	94V-0
I	50-29-1599	5559-05P4-210	5	W/EARS	PASSIVE	94V-0
I	NO E.D.P.	5559-05P5-210	5	W/O EAR	PASSIVE	94V-0
I	NO E.D.P.	5559-05P5-210-BL	5	W/O EAR	PASSIVE	94V-0
H	NO E.D.P.	5559-06P4	6	W/EARS	PASSIVE	94V-2
H	NO E.D.P.	5559-06P5	6	W/O EAR	PASSIVE	94V-2
H	NO E.D.P.	5559-06P4-210	6	W/EARS	PASSIVE	94V-0
H	NO E.D.P.	5559-06P5-210	6	W/O EAR	PASSIVE	94V-0
G	NO E.D.P.	5559-07P4	7	W/EARS	PASSIVE	94V-2
G	NO E.D.P.	5559-07P5	7	W/O EAR	PASSIVE	94V-2
G	NO E.D.P.	5559-07P4-210	7	W/EARS	PASSIVE	94V-0
G	NO E.D.P.	5559-07P5-210	7	W/O EAR	PASSIVE	94V-0
F	NO E.D.P.	5559-08P4	8	W/EARS	PASSIVE	94V-2
F	NO E.D.P.	5559-08P5	8	W/O EAR	PASSIVE	94V-2
F	NO E.D.P.	5559-08P4-210	8	W/EARS	PASSIVE	94V-0
F	NO E.D.P.	5559-08P5-210	8	W/O EAR	PASSIVE	94V-0
F	NO E.D.P.	5559-09P4	9	W/EARS	PASSIVE	94V-2
F	NO E.D.P.	5559-09P5	9	W/O EAR	PASSIVE	94V-2
F	NO E.D.P.	5559-09P4-210	9	W/EARS	PASSIVE	94V-0
F	NO E.D.P.	5559-09P5-210	9	W/O EAR	PASSIVE	94V-0
E	NO E.D.P.	5559-10P4	10	W/EARS	PASSIVE	94V-2
E	NO E.D.P.	5559-10P5	10	W/O EAR	PASSIVE	94V-2
E	NO E.D.P.	5559-10P4-210	10	W/EARS	PASSIVE	94V-0
E	NO E.D.P.	5559-10P5-210	10	W/O EAR	PASSIVE	94V-0
D	NO E.D.P.	5559-11P4	11	W/EARS	PASSIVE	94V-2
D	NO E.D.P.	5559-11P5	11	W/O EAR	PASSIVE	94V-2
D	NO E.D.P.	5559-11P4-210	11	W/EARS	PASSIVE	94V-0
D	NO E.D.P.	5559-11P5-210	11	W/O EAR	PASSIVE	94V-0
D	NO E.D.P.	5559-12P4	12	W/EARS	PASSIVE	94V-2
D	NO E.D.P.	5559-12P5	12	W/O EAR	PASSIVE	94V-2
D	NO E.D.P.	5559-12P4-210	12	W/EARS	PASSIVE	94V-0
D	NO E.D.P.	5559-12P5-210	12	W/O EAR	PASSIVE	94V-0

LEGEND

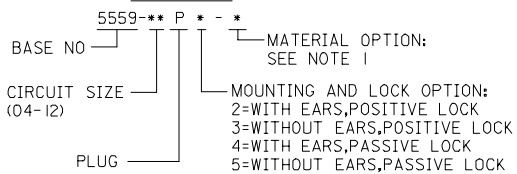

SEE SHEET 1 FCC NO: UCP2006-0276 DRAWNDONNE 2005/08/09 CHKD:GOLGAR 2005/08/09 APPR: JCMERC1 2005/08/11 REV DESCRIPTION	QUALITY SYMBOLS 	GENERAL TOLERANCES (UNLESS SPECIFIED) <table border="1"> <tr><th colspan="2">mm</th><th colspan="2">INCH</th></tr> <tr><td>4 PLACES</td><td>± .010</td><td>± .0004</td><td>± .0001</td></tr> <tr><td>3 PLACES</td><td>± .015</td><td>± .0005</td><td>± .0001</td></tr> <tr><td>2 PLACES</td><td>± 0.25</td><td>± .015</td><td>± .005</td></tr> <tr><td>1 PLACE</td><td>± 0.38</td><td>± .015</td><td>± .005</td></tr> </table>	mm		INCH		4 PLACES	± .010	± .0004	± .0001	3 PLACES	± .015	± .0005	± .0001	2 PLACES	± 0.25	± .015	± .005	1 PLACE	± 0.38	± .015	± .005	DIMENSION STYLE IN/MM DRAWN BY: RJF DATE: 10/13/89 CHECKED BY: BAP DATE: 10/13/89 APPROVED BY: RAS DATE: 10/13/89	SCALE: 1:1 DESIGN UNITS: METRIC THIRD ANGLE PROJECTION
	mm		INCH																					
	4 PLACES	± .010	± .0004	± .0001																				
	3 PLACES	± .015	± .0005	± .0001																				
2 PLACES	± 0.25	± .015	± .005																					
1 PLACE	± 0.38	± .015	± .005																					
DRAFT WHERE APPLICABLE MUST REMAIN WITHIN DIMENSIONS		SEE CHART	MOLEX MOLEX INCORPORATED MATERIAL NO. SD-5559-NLP* DOCUMENT NO. SHEET NO. 2																					
THIS DRAWING CONTAINS INFORMATION THAT IS PROPRIETARY TO MOLEX INCORPORATED AND SHOULD NOT BE USED WITHOUT WRITTEN PERMISSION																								