

Distributed by:

JAMECO[®]
ELECTRONICS

www.Jameco.com ♦ 1-800-831-4242

The content and copyrights of the attached
material are the property of its owner.

Jameco Part Number 1443428

4.20mm (.165") Pitch Mini-Fit Jr.™ Header

5566 Vertical, Single Row With Pegs

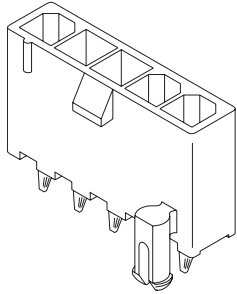

Features and Benefits

- Positive housing locks to mate with Mini-Fit Jr. single row receptacles 5557
- Fully isolated terminals to protect contacts from damage
- Peg-mounted vertical headers for increased board retention
- Drain holes are standard to allow washing of PCB after processing (contact Molex for headers without drain holes)

Reference Information

Packaging: Tube or bag
 UL File No.: E29179
 CSA File No.: LR19980
 TUV License No.: R75142
 Mates With: 5557 single row receptacle
 PCB Thickness: 1.60mm (.062")
 Process: Wave solder
 Designed In: Millimeters

Electrical

Voltage: 600V
 Current: (Used with 16 AWG)

Series	Circuits			
	2-3	4-6	7-10	12-24
46083	9.0A	8.0A	7.0A	6.0A

Contact Resistance: 10 milliohms max.
 Dielectric Withstanding Voltage: 1500V AC
 Insulation Resistance: 1000 Megohms min.

Mechanical

Insertion Force to PCB: 5.0kg max.
 Durability: 30 cycles

Physical

Housing: 6/6 nylon, UL 94V-2 or 94V-0
 Contact: Brass or Phosphor Bronze
 Plating: Tin or Select Gold
 Underplating: Nickel
 Operating Temperature: -40 to +105°C

Circuits	Order No.				Lead-free
	Tin Plated		Select Gold Plated (30µ")		
	94V-2	94V-0	94V-2	94V-0	
3	39-30-5039	39-30-6030	39-30-2037	39-30-2038	Yes
4	39-30-5049	50-30-4466	39-30-2047	39-30-2048	
5		50-30-4467		39-30-2058	

4.20mm (.165") Pitch Mini-Fit Jr.™ Header

5569 Right Angle, Single Row With Pegs

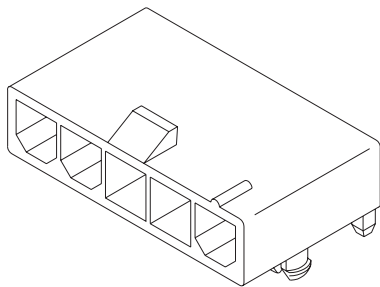

Features and Benefits

- Pegs provide increased board retention
- Ideal for low profile power applications
- Positive housing locks to mate with Mini-Fit Jr. single row receptacles 5557
- Fully isolated terminals to protect contacts from damage

Reference Information

Packaging: Tray or bag
 UL File No.: E29179
 CSA File No.: LR19980
 Mates With: 5557 single row receptacle
 TUV License No.: R75142
 PCB Thickness: 1.60mm (.062")
 Process: Wave solder
 Designed In: Millimeters

Electrical

Voltage: 600V
 Current: (Used with 16 AWG)

Series	Circuits			
	2-3	4-6	7-10	12-24
46083	9.0A	8.0A	7.0A	6.0A
45750	12.0A	12.0A	12.0A	11.0A

Contact Resistance: 10 milliohms max.
 Dielectric Withstanding Voltage: 1500V AC
 Insulation Resistance: 1000 Megohms min.

Mechanical

Insertion Force to PCB: 5.0kg max.
 Durability: 30 cycles

Physical

Housing: 6/6 nylon, UL 94V-2 or 94V-0
 Contact: Brass
 Plating: Tin or Select Gold
 Underplating: Nickel
 Operating Temperature: -40 to +105°C

Circuits	Order No.				Lead-free
	Tin Plated		Select Gold Plated		
	94V-2	94V-0	94V-2	94V-0	
3	39-30-7031	39-30-7032	39-30-4031	39-30-4032	Yes
4	39-30-7041	39-30-7042	50-30-4438	50-30-4441	
5	39-30-7051	39-30-7052	50-30-4439	50-30-4442	

4.20mm (.165") Pitch Mini-Fit Jr.™ Plug

5559

Dual Row
With and without Panel Mount Ears

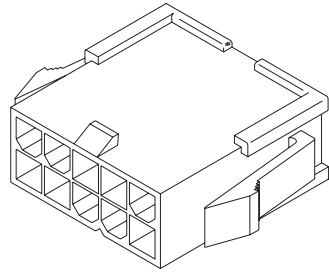

Features and Benefits

- Wire-to-wire plug for panel-mounted or free-hanging applications
- Positive housing locks to mate with Mini-Fit Jr. receptacle
- Fully isolated terminals to protect contacts from damage

Reference Information

Packaging: Bag
 UL File No.: E29179
 CSA File No.: LR19980
 TUV License No.: R75142
 Mates With: 5557 dual row receptacle
 Use With: 5558, 30490, 46134 or 46012 terminals
 Panel Thickness: .079 to 2.00mm (.031 to 0.80")
 Designed In: Millimeters

Mechanical

Contact Insertion Force: 1.5kg max.
 Contact Retention to Housing: 3.0kg min.

Physical

Housing: 6/6 nylon, UL 94V-2 or 94V-0
 Operating Temperature: -40 to +105°C

Circuits	Order No.			
	Panel Mount		Free Hanging	
	94V-2	94V-0	94V-2	94V-0
2	39-01-2021	39-01-2026	39-01-3023	39-01-3029
4	39-01-2041	39-01-2046	39-01-3043	39-01-3049
6	39-01-2061	39-01-2066	39-01-3063	39-01-3069
8	39-01-2081	39-01-2086	39-01-3083	39-01-3089
10	39-01-2101	39-01-2106	39-01-3103	39-01-3109
12	39-01-2121	39-01-2126	39-01-3123	39-01-3129
14	39-01-2141	39-01-2146	39-01-3143	39-01-3149
16	39-01-2161	39-01-2166	39-01-3163	39-01-3169
18	39-01-2181		39-01-3183	
20	39-01-2201			
22	39-01-2221			
24	39-01-2241	39-01-2246		

4.20mm (.165") Pitch Mini-Fit Jr.™ Header

5566

Vertical, Dual Row
With Pegs, with Drain Holes

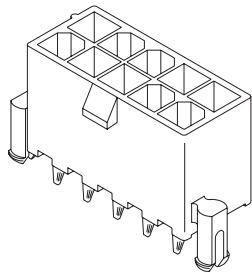

Features and Benefits

- Board-mounting pegs provide polarization during placement on the PCB and increased retention during soldering process
- Positive housing locks to mate with Mini-Fit Jr. receptacle
- Fully isolated terminals to protect contacts from damage
- Drain holes are standard to allow washing of PCB after processing (contact Molex for headers without drain holes)

Reference Information

Packaging: Tray or tube
 UL File No.: E29179
 CSA File No.: LR19980
 TUV License No.: R75142
 Mates With: 5557 dual row receptacles
 PCB Thickness: 1.60mm (.062")
 Process: Wave solder
 Designed In: Millimeters

Electrical

Voltage: 600V
 Current: (Used with 16 AWG)

Series	Circuits			
	2-3	4-6	7-10	12-24
46083	9.0A	8.0A	7.0A	6.0A

Contact Resistance: 10 milliohms max.
 Dielectric Withstanding Voltage: 1500V AC
 Insulation Resistance: 1000 Megohms min.

Mechanical

Insertion Force to PCB: 5.0kg max.
 Durability: 30 cycles

Physical

Housing: 6/6 nylon, UL 94V-2 or 94V-0
 Contact: Brass
 Plating: Tin or Select Gold
 Underplating: Nickel
 Operating Temperature: -40 to +105°C

Circuits	Order No.				Lead-free
	Tin Plated		Gold Plated (30µ")		
	94V-2	94V-0	94V-2	94V-0	
2	39-30-6027	39-30-6028	39-29-9024	39-28-9028	Yes
4	39-30-6047	39-30-6048	39-29-9044	39-28-9048	
6	39-30-6067	39-30-6068	39-29-9064	39-28-9068	
8	39-30-6087	39-30-6088	39-29-9084	39-28-9088	
10	39-30-6107	39-30-6108	39-29-9104	39-28-9108	
12	39-30-6127	39-30-6128	39-29-9124	39-28-9128	
14	39-30-6147	39-30-6148	39-29-9144	39-28-9148	
16	39-30-6167	39-30-6168	39-29-9164	39-28-9168	
18	39-30-6187	39-30-6188	39-29-9184	39-28-9188	
20	39-30-6207	39-30-6208	39-29-9204	39-28-9208	
22	39-30-6227	39-30-6228	39-29-9224		
24	39-30-6247	39-30-6248	39-29-9244	39-28-9248	

4.20mm (.165") Pitch Mini-Fit Jr.™ Header

5566 Vertical, Dual Row Without Pegs, without Drain Holes

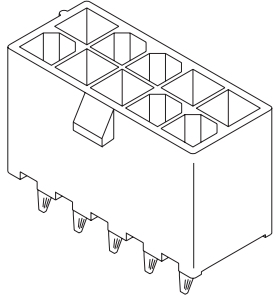

Features and Benefits

- Positive housing locks to mate with Mini-Fit Jr. receptacle
- Fully isolated terminals to protect contacts from damage
- Drain hole option available, contact Molex

Reference Information

Packaging: Bag
 UL File No.: E29179
 CSA File No.: LR19980
 TUV License No.: R75142
 Mates With: 5557 dual row receptacles
 PCB Thickness: 1.60mm (.062")
 Process: Wave solder
 Designed In: Millimeters

Electrical

Voltage: 600V
 Current: (Used with 16 AWG)

Series	Circuits			
	2-3	4-6	7-10	12-24
46083	9.0A	8.0A	7.0A	6.0A

Contact Resistance: 10 milliohms max.
 Dielectric Withstanding Voltage: 1500V AC
 Insulation Resistance: 1000 Megohms min.

Mechanical

Insertion Force to PCB: 5.0kg max.
 Durability: 30 cycles

Physical

Housing: 6/6 nylon, UL 94V-2 or 94V-0
 Contact: Brass or Phosphor Bronze
 Plating: Tin
 Underplating: Copper
 Operating Temperature: -40 to +105°C

Circuits	Order No.		Lead-free
	94V-2	94V-0	
2	39-28-1023	39-28-8020	Yes
4	39-28-1043	39-28-8040	
6	39-28-1063	39-28-8060	
8	39-28-1083	39-28-8080	
10	39-28-1103	39-28-8100	
12	39-28-1123	39-28-8120	

Circuits	Order No.		Lead-free
	94V-2	94V-0	
14	39-28-1143	39-28-8140	Yes
16	39-28-1163	39-28-8160	
18	39-28-1183	39-28-8180	
20	39-28-1203	39-28-8200	
22	39-28-1223	39-28-8220	
24	39-28-1243	39-28-8240	

4.20mm (.165") Pitch Mini-Fit Jr.™ Header

5569 Right Angle, Dual Row with Pegs

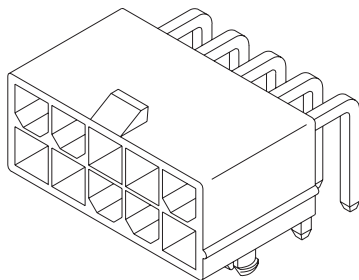

Features and Benefits

- Board mounting pegs provide polarization during placement on PCB and increased board retention during solder processing
- Low profile for space constraints
- Positive housing locks
- Fully isolated terminals to protect contacts from damage

Reference Information

Packaging: Tray
 UL File No.: E29179
 CSA File No.: LR19980
 TUV License No.: R75142
 Mates With: 5557 dual row receptacles
 PCB Thickness: 1.60mm (.062")
 Process: Wave Solder
 Designed In: Millimeters

Electrical

Voltage: 600V
 Current: (Used with 16 AWG)

Series	Circuits			
	2-3	4-6	7-10	12-24
46083	9.0A	8.0A	7.0A	6.0A
45750	12.0A	12.0A	12.0A	11.0A

Contact Resistance: 10 milliohms max.
 Dielectric Withstanding Voltage: 1500V AC
 Insulation Resistance: 1000 Megohms min.

Mechanical

Insertion Force to PCB: 5.0kg max.
 Durability: 30 cycles

Physical

Housing: 6/6 nylon, UL 94V-2 or 94V-0
 Contact: Brass
 Plating: Tin or Select Gold
 Underplating: Nickel
 Operating Temperature: -40 to +105°C

Circuits	Order No.				Lead-free
	Tin Plated		Select Gold Plated (30µ")		
	94V-2	94V-0	94V-2	94V-0	
2	39-30-7025	39-30-7026	39-30-0023	39-30-0024	Yes
4	39-30-7045	39-30-7046	39-30-0043	39-30-0044	
6	39-30-7065	39-30-7066	39-30-0063	39-30-0064	
8	39-30-7085	39-30-7086	39-30-0083	39-30-0084	
10	39-30-7105	39-30-7106	39-30-0103	39-30-0104	
12	39-30-7125	39-30-7126	39-30-0123	39-30-0124	
14	39-30-7145	39-30-7146	39-30-0143	39-30-0144	
16	39-30-7165	39-30-7166	39-30-0163	39-30-0164	
18	39-30-7185		39-30-0183		
20	39-30-7205	39-30-7206	39-30-0203	39-30-0204	
22	39-30-7225				
24	39-30-7245	39-30-7246	39-30-0243	39-30-0244	



PRODUCT SPECIFICATION

MINI-FIT JR.

Table of Contents

<u>Section</u>	<u>Page</u>
1.0 <u>Scope</u>	2
2.0 <u>Product Description</u>	2
2.1 Names and Series Numbers	2
Table 1 – Wire-To-Board	2
Table 1 – Wire-To-Board	2
2.2 Dimensions, Materials, Platings, and Markings	2
2.3 Safety Agency Approvals	2
3.0 <u>Applicable Documents and Specifications</u>	2
4.0 <u>Ratings</u>	3
4.1 Voltage	3
4.2 Applicable Wires	3
4.3 Maximum Current Rating (Amperes)	3
Table 3 – Wire-To-Wire and Wire-To-Board	3
4.4 Temperature	3
4.5 Wave Solder Process Temperature	3
5.0 <u>Wire-To-Wire Performance</u>	4
5.1 Electrical Requirements	4
5.2 Mechanical Requirements	4
5.3 Environmental Requirements	6
6.0 <u>Wire-To-Board Performance</u>	7
6.1 Electrical Requirements	7
6.2 Mechanical Requirements	7
6.3 Environmental Requirements	9
7.0 <u>Test Sequences</u>	9
8.0 <u>Packaging</u>	9

REVISION: E	EGR/ECN INFORMATION: EC No: UCP2007-1117 DATE: 2006 / 10 / 31	TITLE: PRODUCT SPECIFICATION FOR MINI-FIT JR. CONNECTOR SYSTEM	SHEET No. 1 of 9
DOCUMENT NUMBER: PS-5556-001	CREATED / REVISED BY: LSCHMIDT	CHECKED BY: JBELL	APPROVED BY: FSMITH



PRODUCT SPECIFICATION

1.0 SCOPE

This Product Specification covers performance requirements for the MINI-FIT JR. 4.20 mm (.165 inch) centerline (pitch) printed circuit board (PCB) connector series with Tin or Gold plating, and The MINI-FIT JR. connector series terminated with 16 to 28 AWG wire using Crimp technology with Tin or Gold plating.

2.0 PRODUCT DESCRIPTION

2.1 PRODUCT NAME AND SERIES NUMBER (S)

Table 1 – WIRE-TO-WIRE					
Description	Series Number	RoHS	UL	CSA	TUV
Female Crimp Terminal	5556	Yes	n/a	n/a	n/a
Receptacle Housing	5557	Yes	Yes	Yes	Yes
Male Crimp Terminal	5558	Yes	n/a	n/a	n/a
Plug Housing	5559	Yes	Yes	Yes	Yes

Table 2 – WIRE-TO-BOARD					
Description	Series Number	RoHS	UL	CSA	TUV
Female Crimp Terminal	5556	Yes	n/a	n/a	n/a
Receptacle Housing	5557	Yes	Yes	Yes	Yes
Vertical Header	5566	Yes	Yes	Yes	Yes
Right Angle Header	5569	Yes	Yes	Yes	Yes

2.2 DIMENSIONS, MATERIALS, PLATINGS AND MARKINGS

See the appropriate sales drawings for the information on dimensions, materials, platings and markings.

2.3 SAFETY AGENCY APPROVALS

UL File: E29179
CSA Certificate: LR 19980
TUV Certificate: R75142-8

3.0 APPLICABLE DOCUMENTS AND SPECIFICATIONS

See sales drawings and the other sections of this specification for the necessary referenced documents and specifications.

REVISION: E	EGR/ECN INFORMATION: EC No: UCP2007-1117 DATE: 2006 / 10 / 31	TITLE: PRODUCT SPECIFICATION FOR MINI-FIT JR. CONNECTOR SYSTEM	SHEET No. 2 of 9
DOCUMENT NUMBER: PS-5556-001	CREATED / REVISED BY: LSCHMIDT	CHECKED BY: JBELL	APPROVED BY: FSMITH



PRODUCT SPECIFICATION

4.0 RATINGS

4.1 VOLTAGE

600 Volts AC (RMS) (or 600 Volts DC)

4.2 APPLICABLE WIRES

Maximum Insulation Diameter and Applicable Wire Gauges	16 AWG: 3.10 mm / .122 inches MAXIMUM
	18-24 AWG: 3.10 mm / .122 inches MAXIMUM
	22-28 AWG: 1.80 mm / .071 inches MAXIMUM

4.3 MAXIMUM CURRENT RATING (Amperes)

Table 3 - MAXIMUM CURRENT RATING (Amperes)										
Brass					Phosphor Bronze					
Wire \ Ckt. Size	2 & 3	4 - 6	7 - 10	12 - 24	Wire \ Ckt. Size	2 & 3	4 - 6	7 - 10	12 - 24	
AWG #16	9	8	7	6	AWG #16	8	7	6	5	
AWG #18	9	8	7	6	AWG #18	8	7	6	5	
AWG #20	7	6	5	5	AWG #20	6	5	4	4	
AWG #22	5	4	4	4	AWG #22	4	3	3	3	
AWG #24	4	3	3	3	AWG #24	3	2	2	2	
AWG #26	3	2	2	2	AWG #26	2	1	1	1	
AWG #28	2	1	1	1	AWG #28	1	1	1	1	

Note: PCB trace design may greatly affect temperature rise results in Wire-to-Board Applications.

4.4 TEMPERATURE

Operating: * - 40°C to + 105°C

Nonoperating: - 40°C to + 105°C

**Including 30°C terminal temperature at rated current*

4.5 WAVE SOLDER PROCESS TEMPERATURE

Headers with pegs: 240°C Maximum

Headers without pegs: 260°C Maximum

REVISION: E	EGR/ECN INFORMATION: EC No: UCP2007-1117 DATE: 2006 / 10 / 31	TITLE: PRODUCT SPECIFICATION FOR MINI-FIT JR. CONNECTOR SYSTEM	SHEET No. 3 of 9
DOCUMENT NUMBER: PS-5556-001		CREATED / REVISED BY: LSCHMIDT	CHECKED BY: JBELL
		APPROVED BY: FSMITH	



PRODUCT SPECIFICATION

5.0 WIRE-TO-WIRE PERFORMANCE

5.1 ELECTRICAL REQUIREMENTS

ITEM	DESCRIPTION	TEST CONDITION	REQUIREMENT
1	Contact Resistance (Low Level)	Mate connectors: apply a maximum voltage of 20 mV and a current of 100 mA. Wire resistance shall be removed from the measured value.	10 milliohms MAXIMUM [initial]
2	Contact Resistance @ Rated Current	Mate connectors: apply a maximum voltage of 20 mV at rated current.	10 milliohms MAXIMUM [initial]
3	Contact Resistance of Wire Termination (Low Level)	Terminate the applicable wire to the terminal and measure wire using a voltage of 20 mV and a current of 100 mA.	5 milliohms MAXIMUM [initial]
4	Insulation Resistance	Mate connectors: apply a voltage of 500 VDC between adjacent terminals and between terminals to ground.	1000 Megohms MINIMUM
5	Dielectric Withstanding Voltage	Mate connectors: apply a voltage of 1500 VAC for 1 minute between adjacent terminals and between terminals to ground.	No breakdown. Current leakage < 5 mA
6	Temperature Rise (via Current Cycling)	Mate connectors. Measure the temperature rise at the rated current after 96 hours, during current cycling (45 minutes ON and 15 minutes OFF per hour) for 240 hours, and after final 96-hour steady state.	Temperature rise: +30°C MAXIMUM

5.2 MECHANICAL REQUIREMENTS

ITEM	DESCRIPTION	TEST CONDITION	REQUIREMENT
1	Terminal Mate and Unmate Forces Per Circuit	Insert and withdraw terminal (male to female) at a rate of 25 ± 6 mm (1 ± ¼ inch) per minute.	14.7 N (3.30 lbf) MAXIMUM insertion force and 0.5 N (0.11 lbf) MINIMUM withdrawal force
2	Crimp Terminal Retention Force (in Housing)	Axial pullout force on the terminal in the housing at a rate of 25 ± 6 mm (1 ± ¼ inch) per minute.	30 N (6.74 lbf) MINIMUM retention force
3	Durability	Mate connectors up to 30 cycles at a maximum rate of 10 cycles per minute prior to Environmental Tests.	20 milliohms MAXIMUM

REVISION: E	EGR/ECN INFORMATION: EC No: UCP2007-1117 DATE: 2006 / 10 / 31	TITLE: PRODUCT SPECIFICATION FOR MINI-FIT JR. CONNECTOR SYSTEM	SHEET No. 4 of 9
DOCUMENT NUMBER: PS-5556-001	CREATED / REVISED BY: LSCHMIDT	CHECKED BY: JBELL	APPROVED BY: FSMITH



PRODUCT SPECIFICATION

5.2 MECHANICAL REQUIREMENTS (continued)

ITEM	DESCRIPTION	TEST CONDITION	REQUIREMENT
4	Vibration (Random)	Mate connectors and vibrate per EIA 364-28, test condition VII.	10 milliohms MAXIMUM (change from initial) and Discontinuity < 1 microsecond
5	Shock (Mechanical)	Mate connectors and shock at 50 g's with ½ sine wave (11 milliseconds) shocks in the ±X, ±Y, ±Z axes, (18 shocks total).	20 milliohms MAXIMUM and Discontinuity < 1 microsecond
6	Wire Pullout Force (Axial)	Apply an axial pullout force on the wire at a rate of 25 ± 6 mm (1 ± ¼ inch).	16 Awg = 88.0 N (19.8 lbf) Min. 18 Awg = 88.0 N (19.8 lbf) Min. 20 Awg = 59.0 N (13.3 lbf) Min. 22 Awg = 39.0 N (8.78 lbf) Min. 24 Awg = 29.0 N (6.52 lbf) Min. 26 Awg = 19.0 N (4.27 lbf) Min. 28 Awg = 9.80 N (2.20 lbf) Min.
7	Crimp Terminal Insertion Force (into Housing)	Apply an axial insertion force on the terminal at a rate of 25 ± 6 mm (1 ± ¼ inch).	15.0 N (3.37 lbf) MAXIMUM insertion force
8	Normal Force	Apply a perpendicular force.	Sn 1.47 N (150 grams) MINIMUM
			Au 0.49 N (50 grams) MINIMUM
9	Panel Insertion and Withdrawl Forces	Insert and withdraw a connector at a rate of 25 ± 6 mm (1 ± ¼ inch) per minute. (Applies only to plugs with panel retention feature)	225 N (50.7 lbf) MAXIMUM insertion force and 157 N (35.3 lbf) MINIMUM withdrawl force
10	Thumb latch Operation Force	Depress latch at a speed rate of 25 ± 6 mm (1 ± ¼ inch) per minute.	16.67 N (3.75 lbf) MAXIMUM
11	Thumb latch Yield Strength	Mate loaded connectors fully. Pull apart via wires at a speed rate of 25 ± 6 mm (1 ± ¼ inch) per minute.	68 N (15.3 lbf) MINIMUM

REVISION: E	EGR/ECN INFORMATION: EC No: UCP2007-1117 DATE: 2006 / 10 / 31	TITLE: PRODUCT SPECIFICATION FOR MINI-FIT JR. CONNECTOR SYSTEM	SHEET No. 5 of 9
DOCUMENT NUMBER: PS-5556-001	CREATED / REVISED BY: LSCHMIDT	CHECKED BY: JBELL	APPROVED BY: FSMITH



PRODUCT SPECIFICATION

5.3 ENVIRONMENTAL REQUIREMENTS

ITEM	DESCRIPTION	TEST CONDITION	REQUIREMENT
1	Thermal Shock	Mate connectors: expose for 5 cycles Between temperatures -55 and 105°C ; Dwell 0.5 hours at each temperature.	20 milliohms MAXIMUM Visual: No Damage Dielectric Strength per 5.1.5 Insulation Resistance per 5.1.4
2	Thermal Aging	Mate connectors; expose to: 96 hours at $105 \pm 2^{\circ}\text{C}$	20 milliohms MAXIMUM and Visual: No Damage
3	Humidity (Steady State)	Mate connectors: expose to a temperature of $60 \pm 2^{\circ}\text{C}$ with a relative humidity of 90-95% for 96 hours.	20 milliohms MAXIMUM Visual: No Damage Dielectric Strength per 5.1.5 Insulation Resistance per 5.1.4
4	Cold Resistance	Mate connectors: Duration: 96 hours; Temperature: $-40 \pm 3^{\circ}\text{C}$	20 milliohms MAXIMUM and Visual: No Damage
5	Corrosive Atmosphere: Sulfur Dioxide Gas (SO₂)	Mate connectors: Duration: 24 hours exposure. Atmosphere: 50 parts per million (ppm) SO ₂ Gas. Temperature: $40 \pm 3^{\circ}\text{C}$	20 milliohms MAXIMUM and Visual: No Damage

REVISION: E	EGR/ECN INFORMATION: EC No: UCP2007-1117 DATE: 2006 / 10 / 31	TITLE: PRODUCT SPECIFICATION FOR MINI-FIT JR. CONNECTOR SYSTEM	SHEET No. 6 of 9
DOCUMENT NUMBER: PS-5556-001	CREATED / REVISED BY: LSCHMIDT	CHECKED BY: JBELL	APPROVED BY: FSMITH



PRODUCT SPECIFICATION

6.0 WIRE-TO-BOARD PERFORMANCE

6.1 ELECTRICAL REQUIREMENTS

ITEM	DESCRIPTION	TEST CONDITION	REQUIREMENT
1	Contact Resistance (Low Level)	Mate connectors: apply a maximum voltage of 20 mV and a current of 100 mA. Wire resistance shall be removed from the measured value.	10 milliohms MAXIMUM [initial]
2	Contact Resistance @ Rated Current	Mate connectors: apply a maximum voltage of 20 mV at rated current.	10 milliohms MAXIMUM [initial]
3	Contact Resistance of Wire Termination (Low Level)	Terminate the applicable wire to the terminal and measure wire using a voltage of 20 mV and a current of 100 mA.	5 milliohms MAXIMUM [initial]
4	Insulation Resistance	Mate connectors: apply a voltage of 500 VDC between adjacent terminals and between terminals to ground.	1000 Megohms MINIMUM
5	Dielectric Withstanding Voltage	Mate connectors: apply a voltage of 1500 VAC for 1 minute between adjacent terminals and between terminals to ground.	No breakdown. Current leakage < 5 mA
6	Temperature Rise (via Current Cycling)	Mate connectors. Measure the temperature rise at the rated current after 96 hours, during current cycling (45 minutes ON and 15 minutes OFF per hour) for 240 hours, and after final 96-hour steady state.	Temperature rise: +30°C MAXIMUM

6.2 MECHANICAL REQUIREMENTS

ITEM	DESCRIPTION	TEST CONDITION	REQUIREMENT
1	Terminal Mate and Unmate Forces Per Circuit	Insert and withdraw terminal (male to female) at a rate of 25 ± 6 mm (1 ± ¼ inch) per minute.	14.7 N (3.30 lbf) MAXIMUM insertion force and 0.5 N (0.11 lbf) MINIMUM withdrawal force
2	Crimp Terminal Retention Force (in Housing)	Axial pullout force on the terminal in the housing at a rate of 25 ± 6 mm (1 ± ¼ inch) per minute.	30 N (6.74 lbf) MINIMUM retention force
3	Durability	Mate connectors up to 30 cycles at a maximum rate of 10 cycles per minute prior to Environmental Tests.	20 milliohms MAXIMUM

REVISION: E	EGR/ECN INFORMATION: EC No: UCP2007-1117 DATE: 2006 / 10 / 31	TITLE: PRODUCT SPECIFICATION FOR MINI-FIT JR. CONNECTOR SYSTEM	SHEET No. 7 of 9
DOCUMENT NUMBER: PS-5556-001	CREATED / REVISED BY: LSCHMIDT	CHECKED BY: JBELL	APPROVED BY: FSMITH



PRODUCT SPECIFICATION

ITEM	DESCRIPTION	TEST CONDITION	REQUIREMENT
4	Vibration (Random)	Mate connectors and vibrate per EIA 364-28, test condition VII.	10 milliohms MAXIMUM (change from initial) and Discontinuity < 1 microsecond
5	Shock (Mechanical)	Mate connectors and shock at 50 g's with ½ sine wave (11 milliseconds) shocks in the ±X, ±Y, ±Z axes, (18 shocks total).	20 milliohms MAXIMUM and Discontinuity < 1 microsecond
6	Wire Pullout Force (Axial)	Apply an axial pullout force on the wire at a rate of 25 ± 6 mm (1 ± ¼ inch).	16 Awg = 88.0 N (19.8 lbf) Min. 18 Awg = 88.0 N (19.8 lbf) Min. 20 Awg = 59.0 N (13.3 lbf) Min. 22 Awg = 39.0 N (8.78 lbf) Min. 24 Awg = 29.0 N (6.52 lbf) Min. 26 Awg = 19.0 N (4.27 lbf) Min. 28 Awg = 9.80 N (2.20 lbf) Min.
7	Crimp Terminal Insertion Force (into Housing)	Apply an axial insertion force on the terminal at a rate of 25 ± 6 mm (1 ± ¼ inch).	15.0 N (3.37 lbf) MAXIMUM insertion force
8	Normal Force	Apply a perpendicular force.	Sn 1.47 N (150 grams) MINIMUM
			Au 0.49 N (50 grams) MINIMUM
9	PCB Engagement and Separation Forces	Engage and separate a connector at a rate of 25 ± 6 mm (1 ± ¼ inch) per minute. (Applies to parts with PCB retention features only)	49.0 N (11.0 lbf) MAXIMUM insertion force and 10.0 N (2.24 lbf) MINIMUM withdrawal force
10	Pin Retention Force	Apply axial push force at the speed rate of 25 ± 3mm/minute.	9.81 N (2.20 lbf) MAXIMUM
11	Thumb latch Operation Force	Depress latch at a speed rate of 25 ± 6 mm (1 ± ¼ inch) per minute.	16.67 N (3.75 lbf) MAXIMUM
12	Thumb latch Yield Strength	Mate loaded connectors fully. Pull apart via wires at a speed rate of 25 ± 6 mm (1 ± ¼ inch) per minute.	68 N (15.3 lbf) MINIMUM

REVISION: E	EGR/ECN INFORMATION: EC No: UCP2007-1117 DATE: 2006 / 10 / 31	TITLE: PRODUCT SPECIFICATION FOR MINI-FIT JR. CONNECTOR SYSTEM	SHEET No. 8 of 9
DOCUMENT NUMBER: PS-5556-001	CREATED / REVISED BY: LSCHMIDT	CHECKED BY: JBELL	APPROVED BY: FSMITH



PRODUCT SPECIFICATION

6.3 ENVIRONMENTAL REQUIREMENTS

ITEM	DESCRIPTION	TEST CONDITION	REQUIREMENT
1	Thermal Shock	Mate connectors: expose for 5 cycles Between temperatures -55 and 105° C; Dwell 0.5 hours at each temperature.	20 milliohms MAXIMUM Visual: No Damage Dielectric Strength per 6.1.5 Insulation Resistance per 6.1.4
2	Thermal Aging	Mate connectors; expose to: 96 hours at 105 ± 2°C	20 milliohms MAXIMUM and Visual: No Damage
3	Humidity (Steady State)	Mate connectors: expose to a temperature of 60 ± 2°C with a relative humidity of 90- 95% for 96 hours.	20 milliohms MAXIMUM Visual: No Damage Dielectric Strength per 6.1.5 Insulation Resistance per 6.1.4
4	Solderability	Per SMES-152	Solder coverage: 95% MINIMUM (per SMES-152)
5	Solder Resistance	Dip connector terminals tail in solder: Solder Duration: 5 ± 0.5 seconds; Solder Temperature: 260 ± 5°C	Visual: No Damage to insulator material
6	Cold Resistance	Mate connectors: Duration; 96 hours; Temperature: -40 ± 3°C	20 milliohms MAXIMUM and Visual: No Damage
7	Corrosive Atmosphere: Sulfur Dioxide Gas (SO₂)	Mate connectors: Duration; 24 hours exposure. Atmosphere: 50 parts per million (ppm) SO ₂ Gas. Temperature: 40 ± 3°C	20 milliohms MAXIMUM and Visual: No Damage

7.0 TEST SEQUENCES

Testing sequences to be performed in accordance with EIA-364-1000.01

8.0 PACKAGING

Parts shall be packaged to protect against damage during handling, transit and storage.

REVISION: E	EGR/ECN INFORMATION: EC No: UCP2007-1117 DATE: 2006 / 10 / 31	TITLE: PRODUCT SPECIFICATION FOR MINI-FIT JR. CONNECTOR SYSTEM	SHEET No. 9 of 9
DOCUMENT NUMBER: PS-5556-001		CREATED / REVISED BY: LSCHMIDT	CHECKED BY: JBELL
		APPROVED BY: FSMITH	

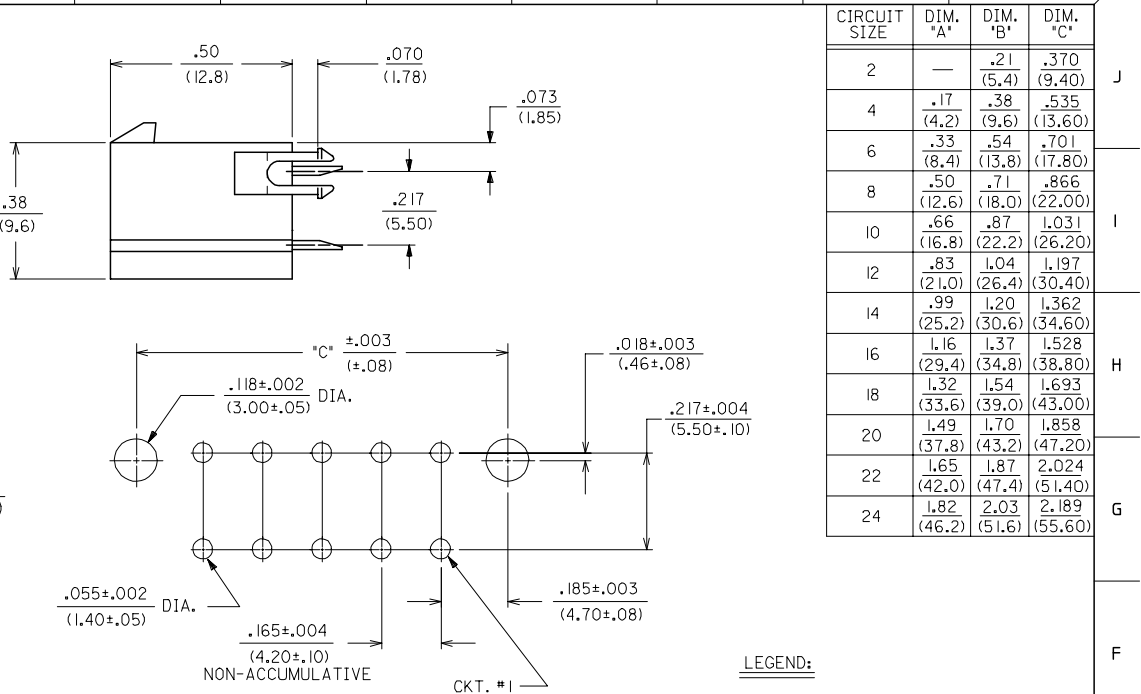
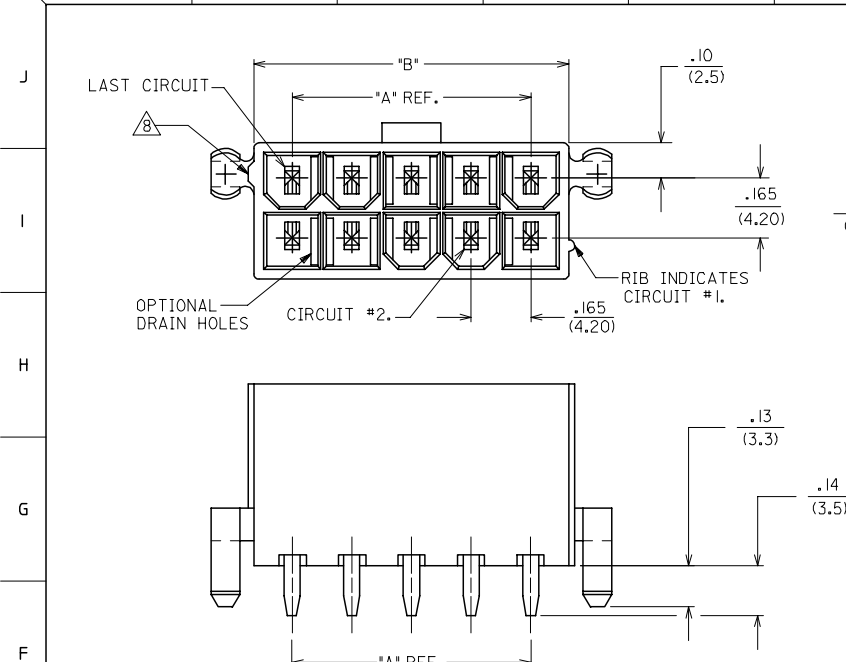

CIRCUIT SIZE	DIM. 'A'	DIM. 'B'	DIM. 'C'
2	—	.21 (5.4)	.370 (9.40)
4	.17 (4.2)	.38 (9.6)	.535 (13.60)
6	.33 (8.4)	.54 (13.8)	.701 (17.80)
8	.50 (12.6)	.71 (18.0)	.866 (22.00)
10	.66 (16.8)	.87 (22.2)	1.031 (26.20)
12	.83 (21.0)	1.04 (26.4)	1.197 (30.40)
14	.99 (25.2)	1.20 (30.6)	1.362 (34.60)
16	1.16 (29.4)	1.37 (34.8)	1.528 (38.80)
18	1.32 (33.6)	1.54 (39.0)	1.693 (43.00)
20	1.49 (37.8)	1.70 (43.2)	1.858 (47.20)
22	1.65 (42.0)	1.87 (47.4)	2.024 (51.40)
24	1.82 (46.2)	2.03 (51.6)	2.189 (55.60)

NOTES:

- HOUSING MATERIAL:
 "BLANK" - NYLON 6/6, U.L. 94V-2, COLOR: NATURAL.
 210 - NYLON 6/6, U.L. 94V-0, COLOR: NATURAL.
 BL - NYLON 6/6, U.L. 94V-2, COLOR: DYED BLACK.
 - TERMINAL MATERIAL: BRASS ALLOY 260
 - PART MATES WITH MINI-FIT JR. RECEPTACLE #5557.
 - PACKAGING: SEE CHARTS
 - MOUNTING OPTIONS:
 "BLANK" - NO MOUNTING (SEE SD-5566-NA AND -NB SERIES DWGS.)
 2 - PEG MOUNT
 - TERMINAL PLATING:
 "BLANK" - .000035/(.00090) MIN. TIN OVER .000020/(.00050) MIN. COPPER.
 *GS - .000030/(.00076) MIN. SELECT GOLD .000100/(.00254) MIN. SELECT MATTE TIN OVER .000050/(.00127) MIN. NICKEL OVERALL.
 *GS2 - .000015/(.00038) MIN. SELECT GOLD AND .000100/(.00254) MIN. SELECT MATTE TIN OVER .000050/(.00127) MIN. NICKEL OVERALL.
 S - .000100/(.00254) MIN. TIN OVER .000050/(.00127) MIN. NICKEL.
- *THE PRIMARY SHIPPING CARTON WILL BE LABELED 'COMPLIANT TO RoHS DIRECTIVE 2002/95/EC AND ELV ANNEX II OF DIRECTIVE 2000/53/EC.'
 *CARTONS WITHOUT THIS LABEL MAY CONTAIN PRODUCT WITH TIN-LEAD PLATING.
- PRODUCT SPECIFICATION AND PROCESSING PARAMETERS: SEE PS-5556-001
 - ANTI-SHINGLING RIB MAY OR MAY NOT APPEAR ON HOUSINGS.
 - CONNECTORS ARE NOT TO BE MATED OR UNMATED WHILE CIRCUITS ARE LIVE.
 - PARTS ARE NOT DESIGNED FOR CURRENT SHARING.

RECOMMENDED HOLE LAYOUT FOR .070(1.78) MAX. THICK P. C. BOARD
 VIEWED FROM COMPONENT SIDE

LEGEND:

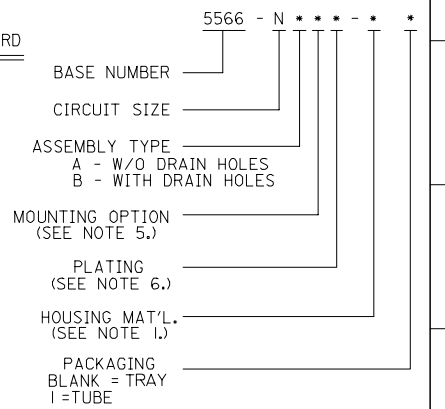

4	0
3	0
2	0
1	R1
SHT. REV.	

REVISED NOTES 8 EC NO: UICP2006-2601 DRAWN: ADRIAN NOL 2006/05/11 CHKD: G POLGAR 2006/05/13 APPR: J COMERCIAL 2006/05/15	QUALITY SYMBOLS ▽=0 ▽=0	GENERAL TOLERANCES (UNLESS SPECIFIED) mm INCH 4 PLACES ± --- ± --- 3 PLACES ± --- ± .015 2 PLACES ± 0.38 ± --- 1 PLACE ± --- ± --- ANGULAR ±1/2°	DIMENSION STYLE IN/MM DRAWN BY DATE RJF 8/19/87 CHECKED BY DATE GT 8/19/87 APPROVED BY DATE RAS 8/19/87	SCALE 4:1 DESIGN UNITS METRIC THIRD ANGLE PROJECTION	TITLE MINI-FIT JR. VERTICAL HEADER ASSEMBLIES WITH MOUNTING PEGS MOLEX MOLEX INCORPORATED	SHEET NO. 1 OF 4
		DRAFT WHERE APPLICABLE MUST REMAIN WITHIN DIMENSIONS	MATERIAL NO. SEE SHTS 2-4	DOCUMENT NO. SDA-5566-N*2*-*	THIS DRAWING CONTAINS INFORMATION THAT IS PROPRIETARY TO MOLEX INCORPORATED AND SHOULD NOT BE USED WITHOUT WRITTEN PERMISSION	
		R1				
		R1				

	13		12		11		10		9		8		7		6		5		4		3		2		1
J	PLATING:		35 M.I. TIN				PLATING:		35 M.I. TIN				PLATING:		30 M.I. GOLD				PLATING:		30 M.I. GOLD				
	DRAIN HOLES:		WITHOUT DRAIN HOLES				DRAIN HOLES:		WITHOUT DRAIN HOLES				DRAIN HOLES:		WITHOUT DRAIN HOLES				DRAIN HOLES:		WITHOUT DRAIN HOLES				
	MTG. OPTION:		WITH PEGS				MTG. OPTION:		WITH PEGS				MTG. OPTION:		WITH PEGS				MTG. OPTION:		WITH PEGS				
	HOUSING MAT'L:		NYLON 6/6 94V-2 NATURAL				HOUSING MAT'L:		NYLON 6/6 94V-0 NATURAL				HOUSING MAT'L:		NYLON 6/6 94V-2 NATURAL				HOUSING MAT'L:		NYLON 6/6 94V-0 NATURAL				
PACKAGING:		TRAY				PACKAGING:		TRAY				PACKAGING:		TRAY				PACKAGING:		TRAY					
I	PART NO.	ENG NO.	CKTS				PART NO.	ENG NO.	CKTS				PART NO.	ENG NO.	CKTS				PART NO.	ENG NO.	CKTS				
	39-29-9023	5566 -02A2	2				39-29-9027	5566 -02A2-2I0	2				39-29-9025	5566 -02A2GS	2				39-29-9029	5566 -02A2GS-2I0	2				
	39-29-9043	5566 -04A2	4				39-29-9047	5566 -04A2-2I0	4				39-29-9045	5566 -04A2GS	4				39-29-9049	5566 -04A2GS-2I0	4				
	39-29-9063	5566 -06A2	6				39-29-9067	5566 -06A2-2I0	6				39-29-9065	5566 -06A2GS	6				39-29-9069	5566 -06A2GS-2I0	6				
	39-29-9083	5566 -08A2	8				39-29-9087	5566 -08A2-2I0	8				39-29-9085	5566 -08A2GS	8				39-29-9089	5566 -08A2GS-2I0	8				
	39-29-9103	5566 -10A2	10				39-29-9107	5566 -10A2-2I0	10				39-29-9105	5566 -10A2GS	10				39-29-9109	5566 -10A2GS-2I0	10				
	39-29-9123	5566 -12A2	12				39-29-9127	5566 -12A2-2I0	12				39-29-9125	5566 -12A2GS	12				39-29-9129	5566 -12A2GS-2I0	12				
	39-29-9143	5566 -14A2	14				39-29-9147	5566 -14A2-2I0	14				39-29-9145	5566 -14A2GS	14				39-29-9149	5566 -14A2GS-2I0	14				
	39-29-9163	5566 -16A2	16				39-29-9167	5566 -16A2-2I0	16				39-29-9165	5566 -16A2GS	16				39-29-9169	5566 -16A2GS-2I0	16				
	39-29-9183	5566 -18A2	18				39-29-9187	5566 -18A2-2I0	18				39-29-9185	5566 -18A2GS	18				39-29-9189	5566 -18A2GS-2I0	18				
H	39-29-9203	5566 -20A2	20				39-29-9207	5566 -20A2-2I0	20				39-29-9205	5566 -20A2GS	20				39-29-9209	5566 -20A2GS-2I0	20				
	39-29-9223	5566 -22A2	22				39-29-9227	5566 -22A2-2I0	22				39-29-9225	5566 -22A2GS	22				39-29-9229	5566 -22A2GS-2I0	22				
	39-29-9243	5566 -24A2	24				39-29-9247	5566 -24A2-2I0	24				39-29-9245	5566 -24A2GS	24				39-29-9249	5566 -24A2GS-2I0	24				
		-						-						-						-					

G	PLATING:		35 M.I. TIN				PLATING:		35 M.I. TIN				PLATING:		30 M.I. GOLD				PLATING:		30 M.I. GOLD			
	DRAIN HOLES:		WITH DRAIN HOLES				DRAIN HOLES:		WITH DRAIN HOLES				DRAIN HOLES:		WITH DRAIN HOLES				DRAIN HOLES:		WITH DRAIN HOLES			
	MTG. OPTION:		WITH PEGS				MTG. OPTION:		WITH PEGS				MTG. OPTION:		WITH PEGS				MTG. OPTION:		WITH PEGS			
	HOUSING MAT'L:		NYLON 6/6 94V-2 NATURAL				HOUSING MAT'L:		NYLON 6/6 94V-0 NATURAL				HOUSING MAT'L:		NYLON 6/6 94V-2 NATURAL				HOUSING MAT'L:		NYLON 6/6 94V-0 NATURAL			
PACKAGING:		TRAY				PACKAGING:		TRAY				PACKAGING:		TRAY				PACKAGING:		TRAY				
F	PART NO.	ENG NO.	CKTS				PART NO.	ENG NO.	CKTS				PART NO.	ENG NO.	CKTS				PART NO.	ENG NO.	CKTS			
	39-29-9022	5566 -02B2	2				39-29-9026	5566 -02B2-2I0	2				39-29-9024	5566 -02B2GS	2				39-28-9028	5566 -02B2GS-2I0	2			
	39-29-9042	5566 -04B2	4				39-29-9046	5566 -04B2-2I0	4				39-29-9044	5566 -04B2GS	4				39-28-9048	5566 -04B2GS-2I0	4			
	39-29-9062	5566 -06B2	6				39-29-9066	5566 -06B2-2I0	6				39-29-9064	5566 -06B2GS	6				39-28-9068	5566 -06B2GS-2I0	6			
	39-29-9082	5566 -08B2	8				39-29-9086	5566 -08B2-2I0	8				39-29-9084	5566 -08B2GS	8				39-28-9088	5566 -08B2GS-2I0	8			
	39-29-9102	5566 -10B2	10				39-29-9106	5566 -10B2-2I0	10				39-29-9104	5566 -10B2GS	10				39-28-9108	5566 -10B2GS-2I0	10			
	39-29-9122	5566 -12B2	12				39-29-9126	5566 -12B2-2I0	12				39-29-9124	5566 -12B2GS	12				39-28-9128	5566 -12B2GS-2I0	12			
	39-29-9142	5566 -14B2	14				39-29-9146	5566 -14B2-2I0	14				39-29-9144	5566 -14B2GS	14				39-28-9148	5566 -14B2GS-2I0	14			
	39-29-9162	5566 -16B2	16				39-29-9166	5566 -16B2-2I0	16				39-29-9164	5566 -16B2GS	16				39-28-9168	5566 -16B2GS-2I0	16			
	39-29-9182	5566 -18B2	18				39-29-9186	5566 -18B2-2I0	18				39-29-9184	5566 -18B2GS	18				39-28-9188	5566 -18B2GS-2I0	18			
E	39-29-9202	5566 -20B2	20				39-29-9206	5566 -20B2-2I0	20				39-29-9204	5566 -20B2GS	20				39-28-9208	5566 -20B2GS-2I0	20			
	39-29-9222	5566 -22B2	22				39-29-9226	5566 -22B2-2I0	22				39-29-9224	5566 -22B2GS	22				39-28-9228	5566 -22B2GS-2I0	22			
	39-29-9242	5566 -24B2	24				39-29-9246	5566 -24B2-2I0	24				39-29-9244	5566 -24B2GS	24				39-28-9248	5566 -24B2GS-2I0	24			
		-						-						-						-				

D	PLATING:		35 M.I. TIN				PLATING:		35 M.I. TIN				PLATING:		30 M.I. GOLD				PLATING:		30 M.I. GOLD			
	DRAIN HOLES:		WITH DRAIN HOLES				DRAIN HOLES:		WITH DRAIN HOLES				DRAIN HOLES:		WITH DRAIN HOLES				DRAIN HOLES:		WITH DRAIN HOLES			
	MTG. OPTION:		WITH PEGS				MTG. OPTION:		WITH PEGS				MTG. OPTION:		WITH PEGS				MTG. OPTION:		WITH PEGS			
	HOUSING MAT'L:		NYLON 6/6 94V-2 NATURAL				HOUSING MAT'L:		NYLON 6/6 94V-0 NATURAL				HOUSING MAT'L:		NYLON 6/6 94V-2 NATURAL				HOUSING MAT'L:		NYLON 6/6 94V-0 NATURAL			
PACKAGING:		TRAY				PACKAGING:		TRAY				PACKAGING:		TRAY				PACKAGING:		TRAY				
C	PART NO.	ENG NO.	CKTS				PART NO.	ENG NO.	CKTS				PART NO.	ENG NO.	CKTS				PART NO.	ENG NO.	CKTS			
	39-29-9022	5566 -02B2	2				39-29-9026	5566 -02B2-2I0	2				39-29-9024	5566 -02B2GS	2				39-28-9028	5566 -02B2GS-2I0	2			
	39-29-9042	5566 -04B2	4				39-29-9046	5566 -04B2-2I0	4				39-29-9044	5566 -04B2GS	4				39-28-9048	5566 -04B2GS-2I0	4			
	39-29-9062	5566 -06B2	6				39-29-9066	5566 -06B2-2I0	6				39-29-9064	5566 -06B2GS	6				39-28-9068	5566 -06B2GS-2I0	6			
	39-29-9082	5566 -08B2	8				39-29-9086	5566 -08B2-2I0	8				39-29-9084	5566 -08B2GS	8				39-28-9088	5566 -08B2GS-2I0	8			
	39-29-9102	5566 -10B2	10				39-29-9106	5566 -10B2-2I0	10				39-29-9104	5566 -10B2GS	10				39-28-9108	5566 -10B2GS-2I0	10			
	39-29-9122	5566 -12B2	12				39-29-9126	5566 -12B2-2I0	12				39-29-9124	5566 -12B2GS	12				39-28-9128	5566 -12B2GS-2I0	12			
	39-29-9142	5566 -14B2	14				39-29-9146	5566 -14B2-2I0	14				39-29-9144	5566 -14B2GS	14				39-28-9148	5566 -14B2GS-2I0	14			
	39-29-9162	5566 -16B2	16				39-29-9166	5566 -16B2-2I0	16				39-29-9164	5566 -16B2GS	16				39-28-9168	5566 -16B2GS-2I0	16			
	39-29-9182	5566 -18B2	18				39-29-9186	5566 -18B2-2I0	18				39-29-9184	5566 -18B2GS	18				39-28-9188	5566 -18B2GS-2I0	18			
B	39-29-9202	5566 -20B2	20				39-29-9206	5566 -20B2-2I0	20				39-29-9204	5566 -20B2GS	20				39-28-9208	5566 -20B2GS-2I0	20			
	39-29-9222	5566 -22B2	22				39-29-9226	5566 -22B2-2I0	22				39-29-9224	5566 -22B2GS	22				39-28-9228	5566 -22B2GS-2I0	22			
	39-29-9242	5566 -24B2	24				39-29-9246	5566 -24B2-2I0	24				39-29-9244	5566 -24B2GS	24				39-28-9248	5566 -24B2GS-2I0	24			
		-						-						-						-				

A	SEE SHEET 1 FCC NO: UCP2006-1448 DRAWNDUNNE 2005/12/21 CHKD:GOLGAR 2005/12/21 APPR:ICOMERC.L 2005/12/22 REV DESCRIPTION	QUALITY SYMBOLS	$\nabla=0$ $\nabla=0$	GENERAL TOLERANCES (UNLESS SPECIFIED)	DIMENSION STYLE IN/MM	SCALE	DESIGN UNITS	THIRD ANGLE PROJECTION
		4 PLACES ± --- ± --- 3 PLACES ± --- ± .01 2 PLACES ± .25 ± .015 1 PLACE ± .38 ± --- ANGULAR ±1/2°	DRAWN BY RJF CHECKED BY GT APPROVED BY RAS	DATE 8/19/87 DATE 8/19/87 DATE 8/19/87	TITLE MINI-FIT JR. VERT HEADER ASSEMBLIES WITH MOUNTING PEGS	MOLEX INCORPORATED		
		DRAFT WHERE APPLICABLE MUST REMAIN WITHIN DIMENSIONS	MATERIAL NO. SEE CHART	DOCUMENT NO. SDA-5566-N*2*-*	SHEET NO. 2			
		THIS DRAWING CONTAINS INFORMATION THAT IS PROPRIETARY TO MOLEX INCORPORATED AND SHOULD NOT BE USED WITHOUT WRITTEN PERMISSION						