

Distributed by:

JAMECO[®]
ELECTRONICS

www.Jameco.com ♦ 1-800-831-4242

The content and copyrights of the attached
material are the property of its owner.

Jameco Part Number 881830

FEATURES AND SPECIFICATIONS

Features and Benefits

- Board-mounting pegs provide increased retention during soldering process
- Positive housing locks to mate with Mini-Fit, Jr. receptacle
- Fully isolated terminals to protect contacts from damage
- Drain hole option available in vertical headers

Reference Information

Product Specification: PS-5556-0001

Packaging: Tray or bag

UL File No.: E29179

CSA File No.: LR19980

TUV License No.: R75142

Mates With: [5557](#) dual row receptacle

Designed In: Millimeters

Electrical

Voltage: 600V

Current: (Used with 16 AWG)

Circuits	2-3	4-6	7-10	12-24
Amperes-Jr.	9	8	7	6

Electrical (cont'd)

Contact Resistance: 10mΩ max.

Dielectric Withstanding Voltage: 1500V AC

Insulation Resistance: 1000 MΩ min.

Mechanical

Contact Insertion Force: 1.5kg max.

Contact Retention to Housing: 3.0kg min.

Wire Pull-Out Force: 9.0kg min.

Insertion Force to PCB: 5.0kg max.

Mating Force: 0.7kg (1.54 lb) max.

Unmating Force: 0.35kg (0.7 lb) min.

Normal Force: 200g min.

Durability: 30 cycles

Physical

Housing: 6/6 nylon, UL 94V-2 or 94V-0

Contact: Brass or Phosphor Bronze

Plating: Tin, select Gold or overall Gold

Operating Temperature: -40 to +105°C

molex® 4.20mm (.165") Pitch Mini-Fit, Jr.™ Header

5566

Vertical, Dual Row With Pegs

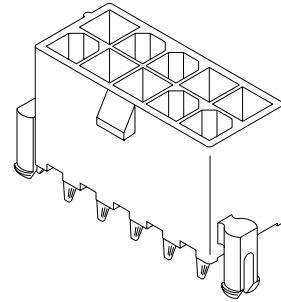

CATALOG DRAWING (FOR REFERENCE ONLY)

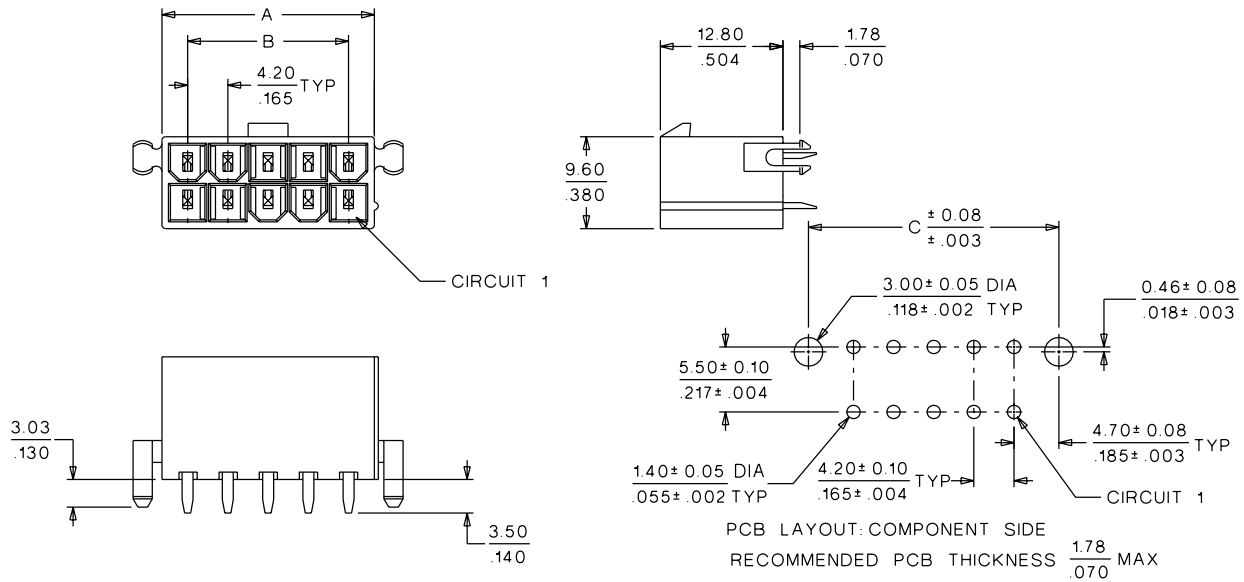

ORDERING INFORMATION AND DIMENSIONS

Circuits	Order No.				Dimension		
	Tin Plated		Gold Plated (30μ")		A	B	C
	94V-2	94V-0	94V-2	94V-0			
2	39-29-9022	39-29-9026	39-29-9024	39-28-9028	5.40 (.210)		9.40 (.370)
4	39-29-9042	39-29-9046	39-29-9044	39-28-9048	9.60 (.380)	4.20 (.170)	13.60 (.535)
6	39-29-9062	39-29-9066	39-29-9064	39-28-9068	13.80 (.540)	8.40 (.330)	17.80 (.701)
8	39-29-9082	39-29-9086	39-29-9084	39-28-9088	18.00 (.710)	12.60 (.500)	22.00 (.866)
10	39-29-9102	39-29-9106	39-29-9104	39-28-9108	22.20 (.870)	16.80 (.660)	26.20 (1.031)
12	39-29-9122	39-29-9126	39-29-9124	39-28-9128	26.40 (1.040)	21.00 (.830)	30.40 (1.197)
14	39-29-9142	39-29-9146	39-29-9144	39-28-9148	30.60 (1.200)	25.20 (.990)	34.60 (1.362)
16	39-29-9162	39-29-9166	39-29-9164	39-28-9168	34.80 (1.370)	29.40 (1.160)	38.80 (1.528)
18	39-29-9182	39-29-9186	39-29-9184	39-28-9188	39.00 (1.540)	33.60 (1.320)	43.00 (1.693)
20	39-29-9202	39-29-9206	39-29-9204	39-28-9208	43.20 (1.700)	37.80 (1.490)	47.20 (1.858)
22	39-29-9222		39-29-9224		47.40 (1.870)	42.00 (1.650)	51.40 (2.024)
24	39-29-9242	39-29-9246	39-29-9244	39-28-9248	51.60 (2.030)	46.20 (1.820)	55.60 (2.189)

Circuits	Order No.				Dimension		
	Tin Plated		Gold Plated (30μ")		A	B	C
	94V-2	94V-0	94V-2	94V-0			
2	39-29-9023	39-29-9027	39-29-9025	39-29-9029	5.40 (.210)		9.40 (.370)
4	39-29-9043	39-29-9047	39-29-9045	39-29-9049	9.60 (.380)	4.20 (.170)	13.60 (.535)
6	39-29-9063	39-29-9067	39-29-9065	39-29-9069	13.80 (.540)	8.40 (.330)	17.80 (.701)
8	39-29-9083	39-29-9087	39-29-9085	39-29-9089	18.00 (.710)	12.60 (.500)	22.00 (.866)
10	39-29-9103	39-29-9107	39-29-9105	39-29-9109	22.20 (.870)	16.80 (.660)	26.20 (1.031)
12	39-29-9123	39-29-9127	39-29-9125	39-29-9129	26.40 (1.040)	21.00 (.830)	30.40 (1.197)
14	39-29-9143	39-29-9147	39-29-9145	39-29-9149	30.60 (1.200)	25.20 (.990)	34.60 (1.362)
16	39-29-9163	39-29-9167	39-29-9165	39-29-9169	34.80 (1.370)	29.40 (1.160)	38.80 (1.528)
18	39-29-9183	39-29-9187	39-29-9185	39-29-9189	39.00 (1.540)	33.60 (1.320)	43.00 (1.693)
20	39-29-9203	39-29-9207	39-29-9205	39-29-9209	43.20 (1.700)	37.80 (1.490)	47.20 (1.858)
24	39-29-9243	39-29-9247	39-29-9245	39-29-9249	51.60 (2.030)	46.20 (1.820)	55.60 (2.189)

• US Standard Product available through Molex franchised distributors



PRODUCT SPECIFICATION

MINI-FIT JR.

1.0 SCOPE

This Product Specification covers performance requirements for the MINI-FIT JR. 4.20 mm (.165 inch) centerline (pitch) printed circuit board (PCB) connector series with Tin or Gold plating, and The MINI-FIT JR. connector series terminated with 16 to 28 AWG wire using Crimp technology with Tin or Gold plating.

2.0 PRODUCT DESCRIPTION

2.1 PRODUCT NAME AND SERIES NUMBER (S)

<u>PRODUCT NAME</u>	<u>PART NUMBER</u>
Female Crimp Terminal	5556-****
Male Crimp Terminal	5558-****
Receptacle Housing	5557-****
Plug Housing	5559-****
Vertical Header Assembly	5566-****
Right Angle Header Assembly	5569-****

2.2 DIMENSIONS, MATERIALS, PLATINGS AND MARKINGS

See the appropriate sales drawings for the information on dimensions, materials, platings and markings.

2.3 SAFETY AGENCY APPROVALS

UL File: E29179
CSA Certificate: LR 19980
TUV Certificate: R75142-8

3.0 APPLICABLE DOCUMENTS AND SPECIFICATIONS

See sales drawings and the other sections of this specification for the necessary referenced documents and specifications

4.0 RATINGS

4.1 VOLTAGE

600 Volts AC (RMS) (or 600 Volts DC)

4.2 CURRENT AND APPLICABLE WIRES

Maximum Insulation Diameter and Applicable Wire Gauges	16 AWG: 3.10/. 122 MAXIMUM
	18-24 AWG: 3.10/. 122 MAXIMUM
	22-28 AWG: 1.80/. 071 MAXIMUM

REVISION: C	EGR/ECN INFORMATION: EC No: UCP2004-2349 DATE: 2004 / 05 / 25	TITLE: PRODUCT SPECIFICATION FOR MINI-FIT JR. CONNECTOR SYSTEM	SHEET No. 1 of 5
DOCUMENT NUMBER: PS-5556-001	CREATED / REVISED BY: BANDURA	CHECKED BY: BANDURA	APPROVED BY: MARGULIS



PRODUCT SPECIFICATION

4.2 CURRENT AND APPLICABLE WIRES (continued)

MAXIMUM CURRENT RATING (Amperes)									
Brass					Phosphor Bronze				
Wire \ Ckt. Size	2 & 3	4 - 6	7 - 10	12 - 24	Wire \ Ckt. Size	2 & 3	4 - 6	7 - 10	12 - 24
AWG #16	9	8	7	6	AWG #16	8	7	6	5
AWG #18	9	8	7	6	AWG #18	8	7	6	5
AWG #20	7	6	5	5	AWG #20	6	5	4	4
AWG #22	5	4	4	4	AWG #22	4	3	3	3
AWG #24	4	3	3	3	AWG #24	3	2	2	2
AWG #26	3	2	2	2	AWG #26	2	1	1	1
AWG #28	2	1	1	1	AWG #28	1	1	1	1

4.3 TEMPERATURE

Operating: * - 40°C to + 105°C

Nonoperating: - 40°C to + 105°C

*Including 30°C terminal temperature at rated current

5.0 PERFORMANCE

5.1 ELECTRICAL REQUIREMENTS

ITEM	DESCRIPTION	TEST CONDITION	REQUIREMENT
1	Contact Resistance (Low Level)	Mate connectors: apply a maximum voltage of 20 mV and a current of 100 mA. Wire resistance shall be removed from the measured value.	10 milliohms MAXIMUM [initial]
2	Contact Resistance @ Rated Current	Mate connectors: apply a maximum voltage of 20 mV at rated current.	10 milliohms MAXIMUM [initial]
3	Contact Resistance of Wire Termination (Low Level)	Terminate the applicable wire to the terminal and measure wire using a voltage of 20 mV and a current of 100 mA.	5 milliohms MAXIMUM [initial]
4	Insulation Resistance	Mate connectors: apply a voltage of 500 VDC between adjacent terminals and between terminals to ground.	1000 Megohms MINIMUM

REVISION: C	EGR/ECN INFORMATION: EC No: UCP2004-2349 DATE: 2004 / 05 / 25	TITLE: PRODUCT SPECIFICATION FOR MINI-FIT JR. CONNECTOR SYSTEM	SHEET No. 2 of 5
DOCUMENT NUMBER: PS-5556-001		CREATED / REVISED BY: BANDURA	CHECKED BY: BANDURA
		APPROVED BY: MARGULIS	



PRODUCT SPECIFICATION

5.1 ELECTRICAL REQUIREMENTS (continued)

ITEM	DESCRIPTION	TEST CONDITION	REQUIREMENT
5	Dielectric Withstanding Voltage	Mate connectors: apply a voltage of 1500 VAC for 1 minute between adjacent terminals and between terminals to ground.	No breakdown. Current leakage < 5 mA
6	Temperature Rise (via Current Cycling)	Mate connectors. Measure the temperature rise at the rated current after 96 hours, during current cycling (45 minutes ON and 15 minutes OFF per hour) for 240 hours, and after final 96-hour steady state.	Temperature rise: +30°C MAXIMUM

5.2 MECHANICAL REQUIREMENTS

ITEM	DESCRIPTION	TEST CONDITION	REQUIREMENT
1	Terminal Insertion and Withdrawal Forces	Insert and withdraw terminal (male to female) at a rate of 25 ± 6 mm (1 ± ¼ inch) per minute.	14.7 N (3.30 lbf) MAXIMUM insertion force & 1.0 N (0.02 lbf) MINIMUM withdrawal force
2	Terminal Retention Force (in Housing)	Axial pullout force on the terminal in the housing at a rate of 25 ± 6 mm (1 ± ¼ inch) per minute.	30 N (6.74 lbf) MINIMUM retention force
3	Durability	Mate connectors up to 30 cycles at a maximum rate of 10 cycles per minute prior to Environmental Tests.	20 milliohms MAXIMUM
4	Vibration (Random)	Mate connectors and vibrate per EIA 364-28, test condition VII.	10 milliohms MAXIMUM (change from initial) & Discontinuity < 1 microsecond
5	Shock (Mechanical)	Mate connectors and shock at 50 g's with ½ sine wave (11 milliseconds) shocks in the ±X, ±Y, ±Z axes, (18 shocks total).	20 milliohms MAXIMUM & Discontinuity < 1 microsecond
6	Wire Pullout Force (Axial)	Apply an axial pullout force on the wire at a rate of 25 ± 6 mm (1 ± ¼ inch).	16 Awg = 88.0 N (19.8 lbf) Min. 18 Awg = 88.0 N (19.8 lbf) Min. 20 Awg = 59.0 N (13.3 lbf) Min. 22 Awg = 39.0 N (8.78 lbf) Min. 24 Awg = 29.0 N (6.52 lbf) Min. 26 Awg = 19.0 N (4.27 lbf) Min. 28 Awg = 9.80 N (2.20 lbf) Min.

<u>REVISION:</u> C	<u>EGR/ECN INFORMATION:</u> EC No: UCP2004-2349 DATE: 2004 / 05 / 25	<u>TITLE:</u> PRODUCT SPECIFICATION FOR MINI-FIT JR. CONNECTOR SYSTEM	<u>SHEET No.</u> 3 of 5
<u>DOCUMENT NUMBER:</u> PS-5556-001	<u>CREATED / REVISED BY:</u> BANDURA	<u>CHECKED BY:</u> BANDURA	<u>APPROVED BY:</u> MARGULIS



PRODUCT SPECIFICATION

5.2 MECHANICAL REQUIREMENTS (continued)

7	Terminal Insertion Force (into Housing)	Apply an axial insertion force on the terminal at a rate of 25 ± 6 mm ($1 \pm \frac{1}{4}$ inch).	15.0 N (3.37 lbf) MAXIMUM insertion force
8	Normal Force	Apply a perpendicular force.	0.49 N (50 grams) MINIMUM [Gold (noble) plating] OR 1.47 N (150 grams) MINIMUM [Tin (non-noble) plating]
9	PCB Engagement and Separation Forces	Engage and separate a connector at a rate of 25 ± 6 mm ($1 \pm \frac{1}{4}$ inch) per minute. (Applies to parts with PCB retention features only)	49.0 N (11.0 lbf) MAXIMUM insertion force & 10.0 N (2.24 lbf) MINIMUM withdrawal force
10	Panel Insertion and Withdrawal Forces	Insert and withdraw a connector at a rate of 25 ± 6 mm ($1 \pm \frac{1}{4}$ inch) per minute. (Applies to parts with panel retention features only)	225 N (50.7 lbf) MAXIMUM insertion force & 157 N (35.3 lbf) MINIMUM withdrawal force
11	Pin Retention Force	Apply axial push force at the speed rate of 25 ± 3 mm/minute.	1.0 KGF MIN.
12	Thumb latch Operation Force	Depress latch at a speed rate of 25.4 mm/minute.	1.7 KGF MAX.
13	Thumb latch Yield Strength	Mate loaded connectors fully. Pull apart via wires at a speed rate of 25.4 mm/minute.	7.0 KGF MIN.

<u>REVISION:</u> C	<u>EGR/ECN INFORMATION:</u> EC No: UCP2004-2349 DATE: 2004 / 05 / 25	<u>TITLE:</u> PRODUCT SPECIFICATION FOR MINI-FIT JR. CONNECTOR SYSTEM	<u>SHEET No.</u> 4 of 5
<u>DOCUMENT NUMBER:</u> PS-5556-001	<u>CREATED / REVISED BY:</u> BANDURA	<u>CHECKED BY:</u> BANDURA	<u>APPROVED BY:</u> MARGULIS



PRODUCT SPECIFICATION

5.3 ENVIRONMENTAL REQUIREMENTS (continued)

ITEM	DESCRIPTION	TEST CONDITION	REQUIREMENT
1	Thermal Shock	Mate connectors: expose for 5 cycles Between temperatures -55 and 105° C; Dwell 0.5 hours at each temperature.	20 milliohms MAXIMUM Visual: No Damage Dielectric Strength per 5.1.5 Insulation Resistance per 5.1.4
2	Thermal Aging	Mate connectors; expose to: 96 hours at 105 ± 2°C	20 milliohms MAXIMUM & Visual: No Damage
3	Humidity (Steady State)	Mate connectors: expose to a temperature of 60 ± 2°C with a relative humidity of 90-95% for 96 hours.	20 milliohms MAXIMUM Dielectric Strength per 5.1.5 Insulation Resistance per 5.1.4 Visual: No Damage
4	Solderability	Per SMES-152	Solder coverage: 95% MINIMUM (per SMES-152)
5	Solder Resistance	Dip connector terminals tail in solder: Solder Duration: 5 ± 0.5 seconds; Solder Temperature: 260 ± 5°C	Visual: No Damage to insulator material
6	Cold Resistance	Mate connectors: Duration; 96 hours; Temperature: -40 ± 3°C	20 milliohms MAXIMUM Visual: No Damage
7	Corrosive Atmosphere: Sulfur Dioxide Gas (SO₂)	Mate connectors: Duration; 24 hours exposure. Atmosphere: 50 parts per million (ppm) SO ₂ Gas. Temperature: 40 ± 3°C	20 milliohms MAXIMUM Visual: No Damage

6.0 PACKAGING

Parts shall be packaged to protect against damage during handling, transit and storage.

REVISION: C	EGR/ECN INFORMATION: EC No: UCP2004-2349 DATE: 2004 / 05 / 25	TITLE: PRODUCT SPECIFICATION FOR MINI-FIT JR. CONNECTOR SYSTEM	SHEET No. 5 of 5
DOCUMENT NUMBER: PS-5556-001	CREATED / REVISED BY: BANDURA	CHECKED BY: BANDURA	APPROVED BY: MARGULIS



PRODUCT SPECIFICATION

<u>REVISION:</u> C	<u>EGR/ECN INFORMATION:</u> <u>EC No:</u> UCP2004-2349 <u>DATE:</u> 2004 / 05 / 25	<u>TITLE:</u> PRODUCT SPECIFICATION FOR MINI-FIT JR. CONNECTOR SYSTEM	<u>SHEET No.</u> 6 of 5
<u>DOCUMENT NUMBER:</u> PS-5556-001	<u>CREATED / REVISED BY:</u> BANDURA	<u>CHECKED BY:</u> BANDURA	<u>APPROVED BY:</u> MARGULIS



PRODUCT SPECIFICATION

<u>REVISION:</u> C	<u>EGR/ECN INFORMATION:</u> EC No: UCP2004-2349 DATE: 2004 / 05 / 25	<u>TITLE:</u> PRODUCT SPECIFICATION FOR MINI-FIT JR. CONNECTOR SYSTEM	<u>SHEET No.</u> 7 of 5
<u>DOCUMENT NUMBER:</u> PS-5556-001	<u>CREATED / REVISED BY:</u> BANDURA	<u>CHECKED BY:</u> BANDURA	<u>APPROVED BY:</u> MARGULIS

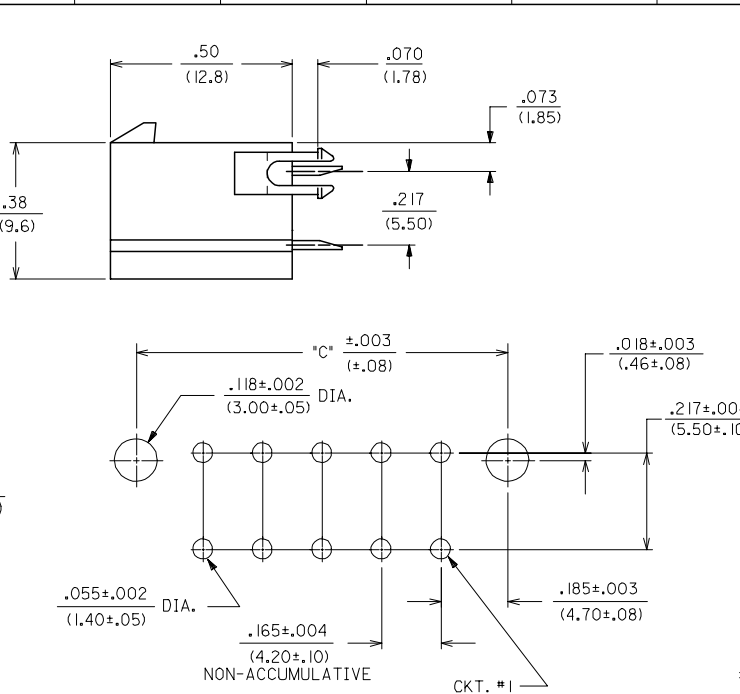
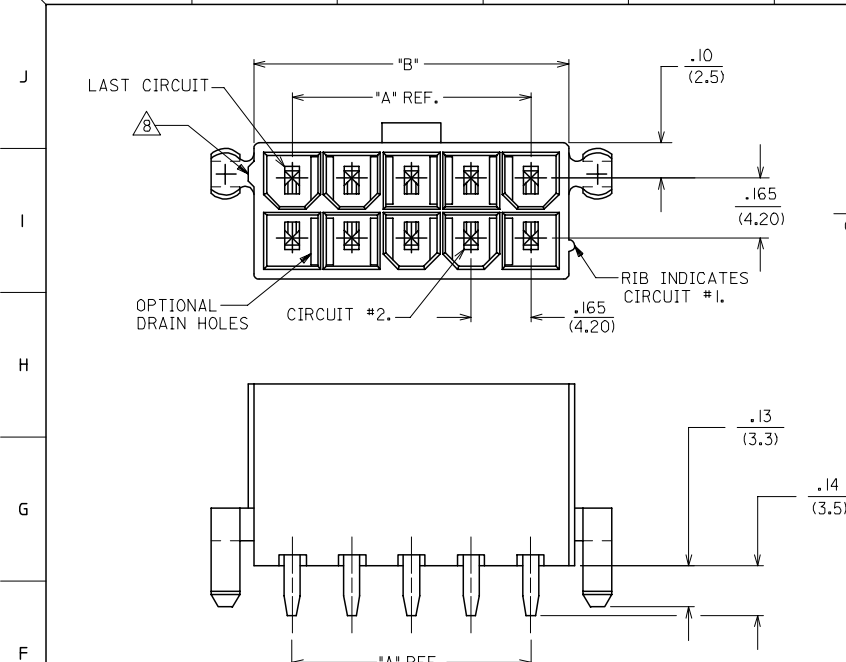

CIRCUIT SIZE	DIM. 'A'	DIM. 'B'	DIM. 'C'
2	—	.21 (5.4)	.370 (9.40)
4	.17 (4.2)	.38 (9.6)	.535 (13.60)
6	.33 (8.4)	.54 (13.8)	.701 (17.80)
8	.50 (12.6)	.71 (18.0)	.866 (22.00)
10	.66 (16.8)	.87 (22.2)	1.031 (26.20)
12	.83 (21.0)	1.04 (26.4)	1.197 (30.40)
14	.99 (25.2)	1.20 (30.6)	1.362 (34.60)
16	1.16 (29.4)	1.37 (34.8)	1.528 (38.80)
18	1.32 (33.6)	1.54 (39.0)	1.693 (43.00)
20	1.49 (37.8)	1.70 (43.2)	1.858 (47.20)
22	1.65 (42.0)	1.87 (47.4)	2.024 (51.40)
24	1.82 (46.2)	2.03 (51.6)	2.189 (55.60)

NOTES:

- HOUSING MATERIAL:
 "BLANK" - NYLON 6/6, U.L. 94V-2, COLOR: NATURAL.
 210 - NYLON 6/6, U.L. 94V-0, COLOR: NATURAL.
 BL - NYLON 6/6, U.L. 94V-2, COLOR: DYED BLACK.
 - TERMINAL MATERIAL: BRASS ALLOY 260
 - PART MATES WITH MINI-FIT JR. RECEPTACLE #5557.
 - PACKAGING: SEE CHARTS
 - MOUNTING OPTIONS:
 "BLANK" - NO MOUNTING (SEE SD-5566-NA AND -NB SERIES DWGS.)
 2 - PEG MOUNT
 - TERMINAL PLATING:
 "BLANK" - .000035/(.00090) MIN. TIN OVER .000020/(.00050) MIN. COPPER.
 *GS - .000030/(.00076) MIN. SELECT GOLD .000100/(.00254) MIN. SELECT MATTE TIN OVER .000050/(.00127) MIN. NICKEL OVERALL.
 *GS2 - .000015/(.00038) MIN. SELECT GOLD AND .000100/(.00254) MIN. SELECT MATTE TIN OVER .000050/(.00127) MIN. NICKEL OVERALL.
 S - .000100/(.00254) MIN. TIN OVER .000050/(.00127) MIN. NICKEL.
- *THE PRIMARY SHIPPING CARTON WILL BE LABELED 'COMPLIANT TO RoHS DIRECTIVE 2002/95/EC AND ELV ANNEX II OF DIRECTIVE 2000/53/EC.'
 *CARTONS WITHOUT THIS LABEL MAY CONTAIN PRODUCT WITH TIN-LEAD PLATING.
- PRODUCT SPECIFICATION AND PROCESSING PARAMETERS: SEE PS-5556-001
 - ANTI-SHINGLING RIB MAY OR MAY NOT APPEAR ON HOUSINGS.
 - CONNECTORS ARE NOT TO BE MATED OR UNMATED WHILE CIRCUITS ARE LIVE.
 - PARTS ARE NOT DESIGNED FOR CURRENT SHARING.

RECOMMENDED HOLE LAYOUT FOR .070/(1.78) MAX. THICK P. C. BOARD
 VIEWED FROM COMPONENT SIDE

LEGEND:

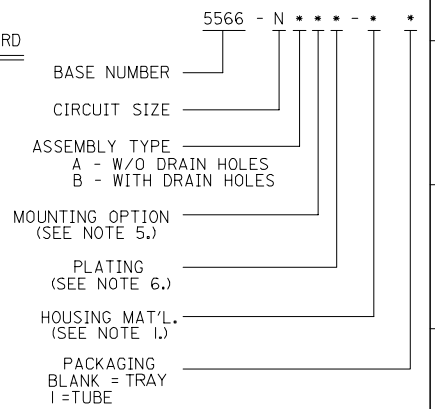

4	Q
3	Q
2	Q
1	R1
SHT. REV.	

REVISED NOTES 8 EC NO: UICP2006-2601 DRAWN: ADRIAN NOL 2006/05/11 CHKD: G POLGAR 2006/05/13 APPR: J COMERCIAL 2006/05/15 R1	QUALITY SYMBOLS ▽=0 ▽=0	GENERAL TOLERANCES (UNLESS SPECIFIED) mm INCH 4 PLACES ± --- ± --- 3 PLACES ± --- ± .015 2 PLACES ± 0.38 ± --- 1 PLACE ± --- ± --- ANGULAR ±1/2°	DIMENSION STYLE IN/MM DRAWN BY DATE RJF 8/19/87 CHECKED BY DATE GT 8/19/87 APPROVED BY DATE RAS 8/19/87	SCALE 4:1 DESIGN UNITS METRIC THIRD ANGLE PROJECTION	TITLE MINI-FIT JR. VERTICAL HEADER ASSEMBLIES WITH MOUNTING PEGS MOLEX MOLEX INCORPORATED	SHEET NO. 1 OF 4
		DRAFT WHERE APPLICABLE MUST REMAIN WITHIN DIMENSIONS	MATERIAL NO. SEE SHTS 2-4	DOCUMENT NO. SDA-5566-N*2*-*	THIS DRAWING CONTAINS INFORMATION THAT IS PROPRIETARY TO MOLEX INCORPORATED AND SHOULD NOT BE USED WITHOUT WRITTEN PERMISSION	

13				12				11				10				9				8				7				6				5				4				3				2				1			
PLATING:				35 M.I. TIN				PLATING:				35 M.I. TIN				PLATING:				30 M.I. GOLD				PLATING:				30 M.I. GOLD																							
DRAIN HOLES:				WITHOUT DRAIN HOLES				DRAIN HOLES:				WITHOUT DRAIN HOLES				DRAIN HOLES:				WITHOUT DRAIN HOLES				DRAIN HOLES:				WITHOUT DRAIN HOLES																							
MTG. OPTION:				WITH PEGS				MTG. OPTION:				WITH PEGS				MTG. OPTION:				WITH PEGS				MTG. OPTION:				WITH PEGS																							
HOUSING MAT'L:				NYLON 6/6 94V-2 NATURAL				HOUSING MAT'L:				NYLON 6/6 94V-0 NATURAL				HOUSING MAT'L:				NYLON 6/6 94V-2 NATURAL				HOUSING MAT'L:				NYLON 6/6 94V-0 NATURAL																							
PACKAGING:				TRAY				PACKAGING:				TRAY				PACKAGING:				TRAY				PACKAGING:				TRAY																							
PART NO.	ENG NO.	CKTS		PART NO.	ENG NO.	CKTS		PART NO.	ENG NO.	CKTS		PART NO.	ENG NO.	CKTS		PART NO.	ENG NO.	CKTS		PART NO.	ENG NO.	CKTS																													
39-29-9023	5566 -02A2	2		39-29-9027	5566 -02A2-2I0	2		39-29-9025	5566 -02A2GS	2		39-29-9029	5566 -02A2GS-2I0	2		39-29-9027	5566 -02A2GS	2		39-29-9031	5566 -02A2GS-2I0	2																													
39-29-9043	5566 -04A2	4		39-29-9047	5566 -04A2-2I0	4		39-29-9045	5566 -04A2GS	4		39-29-9049	5566 -04A2GS-2I0	4		39-29-9047	5566 -04A2GS	4		39-29-9049	5566 -04A2GS-2I0	4																													
39-29-9063	5566 -06A2	6		39-29-9067	5566 -06A2-2I0	6		39-29-9065	5566 -06A2GS	6		39-29-9069	5566 -06A2GS-2I0	6		39-29-9065	5566 -06A2GS	6		39-29-9069	5566 -06A2GS-2I0	6																													
39-29-9083	5566 -08A2	8		39-29-9087	5566 -08A2-2I0	8		39-29-9085	5566 -08A2GS	8		39-29-9089	5566 -08A2GS-2I0	8		39-29-9085	5566 -08A2GS	8		39-29-9089	5566 -08A2GS-2I0	8																													
39-29-9103	5566 -10A2	10		39-29-9107	5566 -10A2-2I0	10		39-29-9105	5566 -10A2GS	10		39-29-9109	5566 -10A2GS-2I0	10		39-29-9105	5566 -10A2GS	10		39-29-9109	5566 -10A2GS-2I0	10																													
39-29-9123	5566 -12A2	12		39-29-9127	5566 -12A2-2I0	12		39-29-9125	5566 -12A2GS	12		39-29-9129	5566 -12A2GS-2I0	12		39-29-9125	5566 -12A2GS	12		39-29-9129	5566 -12A2GS-2I0	12																													
39-29-9143	5566 -14A2	14		39-29-9147	5566 -14A2-2I0	14		39-29-9145	5566 -14A2GS	14		39-29-9149	5566 -14A2GS-2I0	14		39-29-9145	5566 -14A2GS	14		39-29-9149	5566 -14A2GS-2I0	14																													
39-29-9163	5566 -16A2	16		39-29-9167	5566 -16A2-2I0	16		39-29-9165	5566 -16A2GS	16		39-29-9169	5566 -16A2GS-2I0	16		39-29-9165	5566 -16A2GS	16		39-29-9169	5566 -16A2GS-2I0	16																													
39-29-9183	5566 -18A2	18		39-29-9187	5566 -18A2-2I0	18		39-29-9185	5566 -18A2GS	18		39-29-9189	5566 -18A2GS-2I0	18		39-29-9185	5566 -18A2GS	18		39-29-9189	5566 -18A2GS-2I0	18																													
39-29-9203	5566 -20A2	20		39-29-9207	5566 -20A2-2I0	20		39-29-9205	5566 -20A2GS	20		39-29-9209	5566 -20A2GS-2I0	20		39-29-9205	5566 -20A2GS	20		39-29-9209	5566 -20A2GS-2I0	20																													
39-29-9223	5566 -22A2	22		39-29-9227	5566 -22A2-2I0	22		39-29-9225	5566 -22A2GS	22		39-29-9229	5566 -22A2GS-2I0	22		39-29-9225	5566 -22A2GS	22		39-29-9229	5566 -22A2GS-2I0	22																													
39-29-9243	5566 -24A2	24		39-29-9247	5566 -24A2-2I0	24		39-29-9245	5566 -24A2GS	24		39-29-9249	5566 -24A2GS-2I0	24		39-29-9245	5566 -24A2GS	24		39-29-9249	5566 -24A2GS-2I0	24																													
	-				-				-				-				-				-																														

13				12				11				10				9				8				7				6				5				4				3				2				1			
PLATING:				35 M.I. TIN				PLATING:				35 M.I. TIN				PLATING:				30 M.I. GOLD				PLATING:				30 M.I. GOLD																							
DRAIN HOLES:				WITH DRAIN HOLES				DRAIN HOLES:				WITH DRAIN HOLES				DRAIN HOLES:				WITH DRAIN HOLES				DRAIN HOLES:				WITH DRAIN HOLES																							
MTG. OPTION:				WITH PEGS				MTG. OPTION:				WITH PEGS				MTG. OPTION:				WITH PEGS				MTG. OPTION:				WITH PEGS																							
HOUSING MAT'L:				NYLON 6/6 94V-2 NATURAL				HOUSING MAT'L:				NYLON 6/6 94V-0 NATURAL				HOUSING MAT'L:				NYLON 6/6 94V-2 NATURAL				HOUSING MAT'L:				NYLON 6/6 94V-0 NATURAL																							
PACKAGING:				TRAY				PACKAGING:				TRAY				PACKAGING:				TRAY				PACKAGING:				TRAY																							
PART NO.	ENG NO.	CKTS		PART NO.	ENG NO.	CKTS		PART NO.	ENG NO.	CKTS		PART NO.	ENG NO.	CKTS		PART NO.	ENG NO.	CKTS		PART NO.	ENG NO.	CKTS																													
39-29-9022	5566 -02B2	2		39-29-9026	5566 -02B2-2I0	2		39-29-9024	5566 -02B2GS	2		39-28-9028	5566 -02B2GS-2I0	2		39-29-9022	5566 -02B2GS	2		39-28-9026	5566 -02B2GS-2I0	2																													
39-29-9042	5566 -04B2	4		39-29-9046	5566 -04B2-2I0	4		39-29-9044	5566 -04B2GS	4		39-28-9048	5566 -04B2GS-2I0	4		39-29-9042	5566 -04B2GS	4		39-28-9046	5566 -04B2GS-2I0	4																													
39-29-9062	5566 -06B2	6		39-29-9066	5566 -06B2-2I0	6		39-29-9064	5566 -06B2GS	6		39-28-9068	5566 -06B2GS-2I0	6		39-29-9062	5566 -06B2GS	6		39-28-9066	5566 -06B2GS-2I0	6																													
39-29-9082	5566 -08B2	8		39-29-9086	5566 -08B2-2I0	8		39-29-9084	5566 -08B2GS	8		39-28-9088	5566 -08B2GS-2I0	8		39-29-9082	5566 -08B2GS	8		39-28-9086	5566 -08B2GS-2I0	8																													
39-29-9102	5566 -10B2	10		39-29-9106	5566 -10B2-2I0	10		39-29-9104	5566 -10B2GS	10		39-28-9108	5566 -10B2GS-2I0	10		39-29-9102	5566 -10B2GS	10		39-28-9106	5566 -10B2GS-2I0	10																													
39-29-9122	5566 -12B2	12		39-29-9126	5566 -12B2-2I0	12		39-29-9124	5566 -12B2GS	12		39-28-9128	5566 -12B2GS-2I0	12		39-29-9122	5566 -12B2GS	12		39-28-9126	5566 -12B2GS-2I0	12																													
39-29-9142	5566 -14B2	14		39-29-9146	5566 -14B2-2I0	14		39-29-9144	5566 -14B2GS	14		39-28-9148	5566 -14B2GS-2I0	14		39-29-9142	5566 -14B2GS	14		39-28-9146	5566 -14B2GS-2I0	14																													
39-29-9162	5566 -16B2	16		39-29-9166	5566 -16B2-2I0	16		39-29-9164	5566 -16B2GS	16		39-28-9168	5566 -16B2GS-2I0	16		39-29-9162	5566 -16B2GS	16		39-28-9166	5566 -16B2GS-2I0	16																													
39-29-9182	5566 -18B2	18		39-29-9186	5566 -18B2-2I0	18		39-29-9184	5566 -18B2GS	18		39-28-9188	5566 -18B2GS-2I0	18		39-29-9182	5566 -18B2GS	18		39-28-9186	5566 -18B2GS-2I0	18																													
39-29-9202	5566 -20B2	20		39-29-9206	5566 -20B2-2I0	20		39-29-9204	5566 -20B2GS	20		39-28-9208	5566 -20B2GS-2I0	20		39-29-9202	5566 -20B2GS	20		39-28-9206	5566 -20B2GS-2I0	20																													
39-29-9222	5566 -22B2	22		39-29-9226	5566 -22B2-2I0	22		39-29-9224	5566 -22B2GS	22		39-28-9228	5566 -22B2GS-2I0	22		39-29-9222	5566 -22B2GS	22		39-28-9226	5566 -22B2GS-2I0	22																													
39-29-9242	5566 -24B2	24		39-29-9246	5566 -24B2-2I0	24		39-29-9244	5566 -24B2GS	24		39-28-9248	5566 -24B2GS-2I0	24		39-29-9242	5566 -24B2GS	24		39-28-9246	5566 -24B2GS-2I0	24																													
	-				-				-				-				-				-																														

SEE SHEET 1 FCC NO: UCP2006-1448 DRAWNDUNNE 2005/12/21 CHKD:GOLGAR 2005/12/21 APPR:ICOMERC.L 2005/12/22 REV:	QUALITY SYMBOLS 	GENERAL TOLERANCES (UNLESS SPECIFIED) <table border="1"> <tr> <th></th> <th>mm</th> <th>INCH</th> </tr> <tr> <td>4 PLACES</td> <td>± .15</td> <td>± .005</td> </tr> <tr> <td>3 PLACES</td> <td>± .10</td> <td>± .004</td> </tr> <tr> <td>2 PLACES</td> <td>± .075</td> <td>± .003</td> </tr> <tr> <td>1 PLACE</td> <td>± .05</td> <td>± .002</td> </tr> </table>		mm	INCH	4 PLACES	± .15	± .005	3 PLACES	± .10	± .004	2 PLACES	± .075	± .003	1 PLACE	± .05	± .002	DIMENSION STYLE IN/MM	SCALE ---	DESIGN UNITS METRIC	THIRD ANGLE PROJECTION
		mm	INCH																		
	4 PLACES	± .15	± .005																		
	3 PLACES	± .10	± .004																		
2 PLACES	± .075	± .003																			
1 PLACE	± .05	± .002																			
		DRAWN BY RJF DATE 8/19/87	CHECKED BY GT DATE 8/19/87	MINI-FIT JR. VERT HEADER ASSEMBLIES WITH MOUNTING PEGS																	
		APPROVED BY RAS DATE 8/19/87	MATERIAL NO. SEE CHART	MOLEX INCORPORATED																	
		DRAFT WHERE APPLICABLE MUST REMAIN WITHIN DIMENSIONS		SIZE 	DOCUMENT NO. SDA-5566-N*2*-*	SHEET NO. 2															