

Distributed by:

**JAMECO**<sup>®</sup>  
ELECTRONICS

**www.Jameco.com ♦ 1-800-831-4242**

The content and copyrights of the attached  
material are the property of its owner.

Jameco Part Number 882074

## FEATURES AND SPECIFICATIONS

### Features and Benefits

- Board-mounting pegs provide increased retention during soldering process
- Positive housing locks to mate with Mini-Fit, Jr. receptacle
- Fully isolated terminals to protect contacts from damage
- Drain hole option available in vertical headers

### Reference Information

Product Specification: PS-5556-0001

Packaging: Tray or bag

UL File No.: E29179

CSA File No.: LR19980

TUV License No.: R75142

Mates With: 5557 dual row receptacle

Designed In: Millimeters

### Electrical

Voltage: 600V

Current: (Used with 16 AWG)

Circuits	2-3	4-6	7-10	12-24
Amperes-Jr.	9	8	7	6

### Electrical (cont'd)

Contact Resistance: 10mΩ max.

Dielectric Withstanding Voltage: 1500V AC

Insulation Resistance: 1000 MΩ min.

### Mechanical

Contact Insertion Force: 1.5kg max.

Contact Retention to Housing: 3.0kg min.

Wire Pull-Out Force: 9.0kg min.

Insertion Force to PCB: 5.0kg max.

Mating Force: 0.7kg (1.54 lb) max.

Unmating Force: 0.35kg (0.7 lb) min.

Normal Force: 200g min.

Durability: 30 cycles

### Physical

Housing: 6/6 nylon, UL 94V-2 or 94V-0

Contact: Brass or Phosphor Bronze

Plating: Tin, select Gold or overall Gold

Operating Temperature: -40 to +105°C

# molex® 4.20mm (.165") Pitch Mini-Fit, Jr.™ Header

## 5566

## Vertical, Dual Row With Pegs

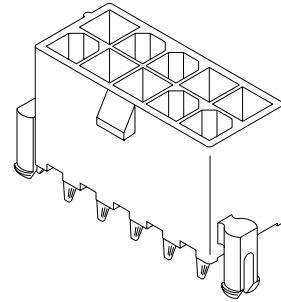

## CATALOG DRAWING (FOR REFERENCE ONLY)

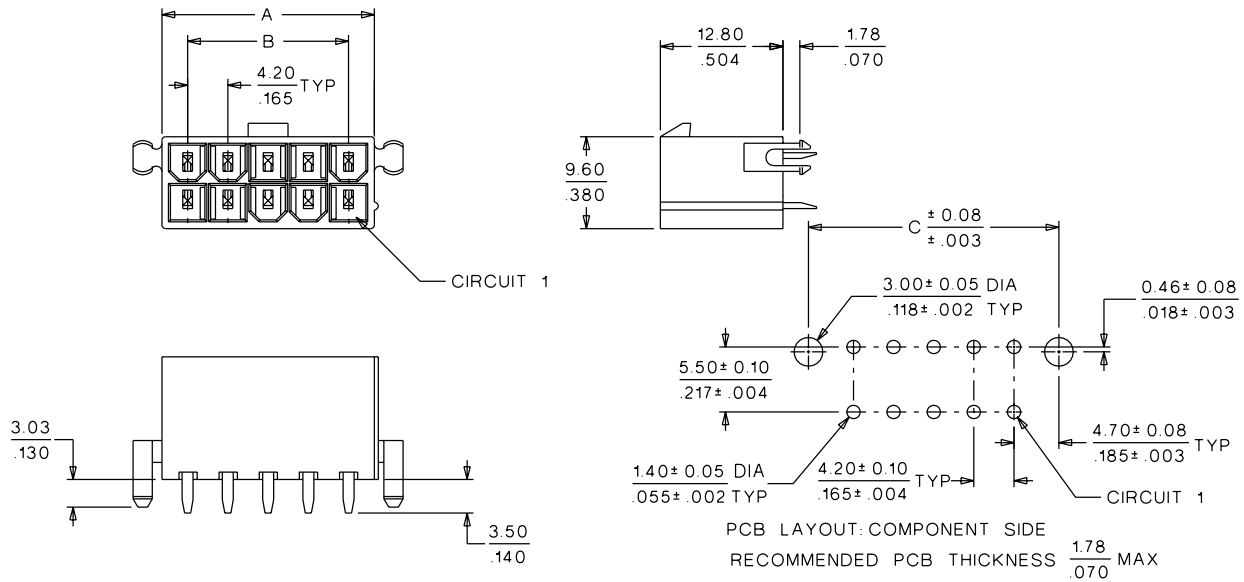

## ORDERING INFORMATION AND DIMENSIONS

Circuits	Order No.				Dimension		
	Tin Plated		Gold Plated (30μ")		A	B	C
	94V-2	94V-0	94V-2	94V-0			
2	39-29-9022	39-29-9026	39-29-9024	39-28-9028	5.40 (.210)		9.40 (.370)
4	39-29-9042	39-29-9046	39-29-9044	39-28-9048	9.60 (.380)	4.20 (.170)	13.60 (.535)
6	39-29-9062	39-29-9066	39-29-9064	39-28-9068	13.80 (.540)	8.40 (.330)	17.80 (.701)
8	39-29-9082	39-29-9086	39-29-9084	39-28-9088	18.00 (.710)	12.60 (.500)	22.00 (.866)
10	39-29-9102	39-29-9106	39-29-9104	39-28-9108	22.20 (.870)	16.80 (.660)	26.20 (1.031)
12	39-29-9122	39-29-9126	39-29-9124	39-28-9128	26.40 (1.040)	21.00 (.830)	30.40 (1.197)
14	39-29-9142	39-29-9146	39-29-9144	39-28-9148	30.60 (1.200)	25.20 (.990)	34.60 (1.362)
16	39-29-9162	39-29-9166	39-29-9164	39-28-9168	34.80 (1.370)	29.40 (1.160)	38.80 (1.528)
18	39-29-9182	39-29-9186	39-29-9184	39-28-9188	39.00 (1.540)	33.60 (1.320)	43.00 (1.693)
20	39-29-9202	39-29-9206	39-29-9204	39-28-9208	43.20 (1.700)	37.80 (1.490)	47.20 (1.858)
22	39-29-9222		39-29-9224		47.40 (1.870)	42.00 (1.650)	51.40 (2.024)
24	39-29-9242	39-29-9246	39-29-9244	39-28-9248	51.60 (2.030)	46.20 (1.820)	55.60 (2.189)

Circuits	Order No.				Dimension		
	Tin Plated		Gold Plated (30μ")		A	B	C
	94V-2	94V-0	94V-2	94V-0			
2	39-29-9023	39-29-9027	39-29-9025	39-29-9029	5.40 (.210)		9.40 (.370)
4	39-29-9043	39-29-9047	39-29-9045	39-29-9049	9.60 (.380)	4.20 (.170)	13.60 (.535)
6	39-29-9063	39-29-9067	39-29-9065	39-29-9069	13.80 (.540)	8.40 (.330)	17.80 (.701)
8	39-29-9083	39-29-9087	39-29-9085	39-29-9089	18.00 (.710)	12.60 (.500)	22.00 (.866)
10	39-29-9103	39-29-9107	39-29-9105	39-29-9109	22.20 (.870)	16.80 (.660)	26.20 (1.031)
12	39-29-9123	39-29-9127	39-29-9125	39-29-9129	26.40 (1.040)	21.00 (.830)	30.40 (1.197)
14	39-29-9143	39-29-9147	39-29-9145	39-29-9149	30.60 (1.200)	25.20 (.990)	34.60 (1.362)
16	39-29-9163	39-29-9167	39-29-9165	39-29-9169	34.80 (1.370)	29.40 (1.160)	38.80 (1.528)
18	39-29-9183	39-29-9187	39-29-9185	39-29-9189	39.00 (1.540)	33.60 (1.320)	43.00 (1.693)
20	39-29-9203	39-29-9207	39-29-9205	39-29-9209	43.20 (1.700)	37.80 (1.490)	47.20 (1.858)
24	39-29-9243	39-29-9247	39-29-9245	39-29-9249	51.60 (2.030)	46.20 (1.820)	55.60 (2.189)

• US Standard Product available through Molex franchised distributors



# PRODUCT SPECIFICATION

## MINI-FIT JR.

### 1.0 SCOPE

This Product Specification covers performance requirements for the MINI-FIT JR. 4.20 mm (.165 inch) centerline (pitch) printed circuit board (PCB) connector series with Tin or Gold plating, and The MINI-FIT JR. connector series terminated with 16 to 28 AWG wire using Crimp technology with Tin or Gold plating.

### 2.0 PRODUCT DESCRIPTION

#### 2.1 PRODUCT NAME AND SERIES NUMBER (S)

<u>PRODUCT NAME</u>	<u>PART NUMBER</u>
Female Crimp Terminal	5556-****
Male Crimp Terminal	5558-****
Receptacle Housing	5557-****
Plug Housing	5559-****
Vertical Header Assembly	5566-****
Right Angle Header Assembly	5569-****

#### 2.2 DIMENSIONS, MATERIALS, PLATINGS AND MARKINGS

See the appropriate sales drawings for the information on dimensions, materials, platings and markings.

#### 2.3 SAFETY AGENCY APPROVALS

UL File: E29179  
CSA Certificate: LR 19980  
TUV Certificate: R75142-8

### 3.0 APPLICABLE DOCUMENTS AND SPECIFICATIONS

See sales drawings and the other sections of this specification for the necessary referenced documents and specifications

### 4.0 RATINGS

#### 4.1 VOLTAGE

600 Volts AC (RMS) (or 600 Volts DC)

#### 4.2 CURRENT AND APPLICABLE WIRES

<b>Maximum Insulation Diameter and Applicable Wire Gauges</b>	16 AWG: 3.10/. 122 MAXIMUM
	18-24 AWG: 3.10/. 122 MAXIMUM
	22-28 AWG: 1.80/. 071 MAXIMUM

<b>REVISION:</b> <b>C</b>	<b>EGR/ECN INFORMATION:</b> EC No: <b>UCP2004-2349</b> DATE: <b>2004 / 05 / 25</b>	<b>TITLE:</b> <b>PRODUCT SPECIFICATION FOR MINI-FIT JR. CONNECTOR SYSTEM</b>	<b>SHEET No.</b> <b>1 of 5</b>
<b>DOCUMENT NUMBER:</b> <b>PS-5556-001</b>	<b>CREATED / REVISED BY:</b> <b>BANDURA</b>	<b>CHECKED BY:</b> <b>BANDURA</b>	<b>APPROVED BY:</b> <b>MARGULIS</b>



# PRODUCT SPECIFICATION

## 4.2 CURRENT AND APPLICABLE WIRES (continued)

MAXIMUM CURRENT RATING (Amperes)									
Brass					Phosphor Bronze				
Wire \ Ckt. Size	2 & 3	4 - 6	7 - 10	12 - 24	Wire \ Ckt. Size	2 & 3	4 - 6	7 - 10	12 - 24
AWG #16	9	8	7	6	AWG #16	8	7	6	5
AWG #18	9	8	7	6	AWG #18	8	7	6	5
AWG #20	7	6	5	5	AWG #20	6	5	4	4
AWG #22	5	4	4	4	AWG #22	4	3	3	3
AWG #24	4	3	3	3	AWG #24	3	2	2	2
AWG #26	3	2	2	2	AWG #26	2	1	1	1
AWG #28	2	1	1	1	AWG #28	1	1	1	1

## 4.3 TEMPERATURE

Operating: \* - 40°C to + 105°C

Nonoperating: - 40°C to + 105°C

\*Including 30°C terminal temperature at rated current

## 5.0 PERFORMANCE

### 5.1 ELECTRICAL REQUIREMENTS

ITEM	DESCRIPTION	TEST CONDITION	REQUIREMENT
1	<b>Contact Resistance (Low Level)</b>	Mate connectors: apply a maximum voltage of 20 mV and a current of 100 mA. Wire resistance shall be removed from the measured value.	10 milliohms MAXIMUM [initial]
2	<b>Contact Resistance @ Rated Current</b>	Mate connectors: apply a maximum voltage of 20 mV at rated current.	10 milliohms MAXIMUM [initial]
3	<b>Contact Resistance of Wire Termination (Low Level)</b>	Terminate the applicable wire to the terminal and measure wire using a voltage of 20 mV and a current of 100 mA.	5 milliohms MAXIMUM [initial]
4	<b>Insulation Resistance</b>	Mate connectors: apply a voltage of 500 VDC between adjacent terminals and between terminals to ground.	1000 Megohms MINIMUM

REVISION: <b>C</b>	EGR/ECN INFORMATION: EC No: <b>UCP2004-2349</b> DATE: <b>2004 / 05 / 25</b>	TITLE: <b>PRODUCT SPECIFICATION FOR MINI-FIT JR. CONNECTOR SYSTEM</b>	SHEET No. <b>2 of 5</b>
DOCUMENT NUMBER: <b>PS-5556-001</b>		CREATED / REVISED BY: <b>BANDURA</b>	CHECKED BY: <b>BANDURA</b>
		APPROVED BY: <b>MARGULIS</b>	



# PRODUCT SPECIFICATION

## 5.1 ELECTRICAL REQUIREMENTS (continued)

ITEM	DESCRIPTION	TEST CONDITION	REQUIREMENT
5	<b>Dielectric Withstanding Voltage</b>	Mate connectors: apply a voltage of 1500 VAC for 1 minute between adjacent terminals and between terminals to ground.	No breakdown. Current leakage < 5 mA
6	<b>Temperature Rise (via Current Cycling)</b>	Mate connectors. Measure the temperature rise at the rated current after 96 hours, during current cycling (45 minutes ON and 15 minutes OFF per hour) for 240 hours, and after final 96-hour steady state.	Temperature rise: +30°C MAXIMUM

## 5.2 MECHANICAL REQUIREMENTS

ITEM	DESCRIPTION	TEST CONDITION	REQUIREMENT
1	<b>Terminal Insertion and Withdrawal Forces</b>	Insert and withdraw terminal (male to female) at a rate of 25 ± 6 mm (1 ± ¼ inch) per minute.	14.7 N (3.30 lbf) MAXIMUM insertion force & 1.0 N (0.02 lbf) MINIMUM withdrawal force
2	<b>Terminal Retention Force (in Housing)</b>	Axial pullout force on the terminal in the housing at a rate of 25 ± 6 mm (1 ± ¼ inch) per minute.	30 N (6.74 lbf) MINIMUM retention force
3	<b>Durability</b>	Mate connectors up to 30 cycles at a maximum rate of 10 cycles per minute prior to Environmental Tests.	20 milliohms MAXIMUM
4	<b>Vibration (Random)</b>	Mate connectors and vibrate per EIA 364-28, test condition VII.	10 milliohms MAXIMUM (change from initial) & Discontinuity < 1 microsecond
5	<b>Shock (Mechanical)</b>	Mate connectors and shock at 50 g's with ½ sine wave (11 milliseconds) shocks in the ±X, ±Y, ±Z axes, (18 shocks total).	20 milliohms MAXIMUM & Discontinuity < 1 microsecond
6	<b>Wire Pullout Force (Axial)</b>	Apply an axial pullout force on the wire at a rate of 25 ± 6 mm (1 ± ¼ inch).	16 Awg = 88.0 N (19.8 lbf) Min. 18 Awg = 88.0 N (19.8 lbf) Min. 20 Awg = 59.0 N (13.3 lbf) Min. 22 Awg = 39.0 N (8.78 lbf) Min. 24 Awg = 29.0 N (6.52 lbf) Min. 26 Awg = 19.0 N (4.27 lbf) Min. 28 Awg = 9.80 N (2.20 lbf) Min.

<u>REVISION:</u> <b>C</b>	<u>EGR/ECN INFORMATION:</u> EC No: <b>UCP2004-2349</b> DATE: <b>2004 / 05 / 25</b>	<u>TITLE:</u> <b>PRODUCT SPECIFICATION FOR MINI-FIT JR. CONNECTOR SYSTEM</b>	<u>SHEET No.</u> <b>3 of 5</b>
<u>DOCUMENT NUMBER:</u> <b>PS-5556-001</b>	<u>CREATED / REVISED BY:</u> <b>BANDURA</b>	<u>CHECKED BY:</u> <b>BANDURA</b>	<u>APPROVED BY:</u> <b>MARGULIS</b>



# PRODUCT SPECIFICATION

## 5.2 MECHANICAL REQUIREMENTS (continued)

7	<b>Terminal Insertion Force (into Housing)</b>	Apply an axial insertion force on the terminal at a rate of $25 \pm 6$ mm ( $1 \pm \frac{1}{4}$ inch).	15.0 N (3.37 lbf) MAXIMUM insertion force
8	<b>Normal Force</b>	Apply a perpendicular force.	0.49 N (50 grams) MINIMUM [Gold (noble) plating] OR 1.47 N (150 grams) MINIMUM [Tin (non-noble) plating]
9	<b>PCB Engagement and Separation Forces</b>	Engage and separate a connector at a rate of $25 \pm 6$ mm ( $1 \pm \frac{1}{4}$ inch) per minute. (Applies to parts with PCB retention features only)	49.0 N (11.0 lbf) MAXIMUM insertion force & 10.0 N (2.24 lbf) MINIMUM withdrawal force
10	<b>Panel Insertion and Withdrawal Forces</b>	Insert and withdraw a connector at a rate of $25 \pm 6$ mm ( $1 \pm \frac{1}{4}$ inch) per minute. (Applies to parts with panel retention features only)	225 N (50.7 lbf) MAXIMUM insertion force & 157 N (35.3 lbf) MINIMUM withdrawal force
11	<b>Pin Retention Force</b>	Apply axial push force at the speed rate of $25 \pm 3$ mm/minute.	1.0 KGF MIN.
12	<b>Thumb latch Operation Force</b>	Depress latch at a speed rate of 25.4 mm/minute.	1.7 KGF MAX.
13	<b>Thumb latch Yield Strength</b>	Mate loaded connectors fully. Pull apart via wires at a speed rate of 25.4 mm/minute.	7.0 KGF MIN.

<u>REVISION:</u> <b>C</b>	<u>EGR/ECN INFORMATION:</u> EC No: <b>UCP2004-2349</b> DATE: <b>2004 / 05 / 25</b>	<u>TITLE:</u> <b>PRODUCT SPECIFICATION FOR MINI-FIT JR. CONNECTOR SYSTEM</b>	<u>SHEET No.</u> <b>4 of 5</b>
<u>DOCUMENT NUMBER:</u> <b>PS-5556-001</b>	<u>CREATED / REVISED BY:</u> <b>BANDURA</b>	<u>CHECKED BY:</u> <b>BANDURA</b>	<u>APPROVED BY:</u> <b>MARGULIS</b>



# PRODUCT SPECIFICATION

## 5.3 ENVIRONMENTAL REQUIREMENTS (continued)

ITEM	DESCRIPTION	TEST CONDITION	REQUIREMENT
1	<b>Thermal Shock</b>	Mate connectors: expose for 5 cycles Between temperatures -55 and 105° C; Dwell 0.5 hours at each temperature.	20 milliohms MAXIMUM Visual: No Damage Dielectric Strength per 5.1.5 Insulation Resistance per 5.1.4
2	<b>Thermal Aging</b>	Mate connectors; expose to: 96 hours at 105 ± 2°C	20 milliohms MAXIMUM & Visual: No Damage
3	<b>Humidity (Steady State)</b>	Mate connectors: expose to a temperature of 60 ± 2°C with a relative humidity of 90-95% for 96 hours.	20 milliohms MAXIMUM Dielectric Strength per 5.1.5 Insulation Resistance per 5.1.4 Visual: No Damage
4	<b>Solderability</b>	Per SMES-152	Solder coverage: 95% MINIMUM (per SMES-152)
5	<b>Solder Resistance</b>	Dip connector terminals tail in solder: Solder Duration: 5 ± 0.5 seconds; Solder Temperature: 260 ± 5°C	Visual: No Damage to insulator material
6	<b>Cold Resistance</b>	Mate connectors: Duration; 96 hours; Temperature: -40 ± 3°C	20 milliohms MAXIMUM Visual: No Damage
7	<b>Corrosive Atmosphere: Sulfur Dioxide Gas (SO<sub>2</sub>)</b>	Mate connectors: Duration; 24 hours exposure. Atmosphere: 50 parts per million (ppm) SO <sub>2</sub> Gas. Temperature: 40 ± 3°C	20 milliohms MAXIMUM Visual: No Damage

## 6.0 PACKAGING

Parts shall be packaged to protect against damage during handling, transit and storage.

REVISION: <b>C</b>	EGR/ECN INFORMATION: EC No: UCP2004-2349 DATE: 2004 / 05 / 25	TITLE: <b>PRODUCT SPECIFICATION FOR MINI-FIT JR. CONNECTOR SYSTEM</b>	SHEET No. <b>5 of 5</b>
DOCUMENT NUMBER: <b>PS-5556-001</b>	CREATED / REVISED BY: <b>BANDURA</b>	CHECKED BY: <b>BANDURA</b>	APPROVED BY: <b>MARGULIS</b>



# PRODUCT SPECIFICATION

<u>REVISION:</u> <b>C</b>	<u>EGR/ECN INFORMATION:</u> <u>EC No:</u> <b>UCP2004-2349</b> <u>DATE:</u> <b>2004 / 05 / 25</b>	<u>TITLE:</u> <b>PRODUCT SPECIFICATION FOR MINI-FIT JR. CONNECTOR SYSTEM</b>	<u>SHEET No.</u> <b>6 of 5</b>
<u>DOCUMENT NUMBER:</u> <b>PS-5556-001</b>	<u>CREATED / REVISED BY:</u> <b>BANDURA</b>	<u>CHECKED BY:</u> <b>BANDURA</b>	<u>APPROVED BY:</u> <b>MARGULIS</b>





# PRODUCT SPECIFICATION

<u>REVISION:</u> <b>C</b>	<u>EGR/ECN INFORMATION:</u> EC No: <b>UCP2004-2349</b> DATE: <b>2004 / 05 / 25</b>	<u>TITLE:</u> <b>PRODUCT SPECIFICATION FOR MINI-FIT JR. CONNECTOR SYSTEM</b>	<u>SHEET No.</u> <b>7 of 5</b>
<u>DOCUMENT NUMBER:</u> <b>PS-5556-001</b>	<u>CREATED / REVISED BY:</u> <b>BANDURA</b>	<u>CHECKED BY:</u> <b>BANDURA</b>	<u>APPROVED BY:</u> <b>MARGULIS</b>

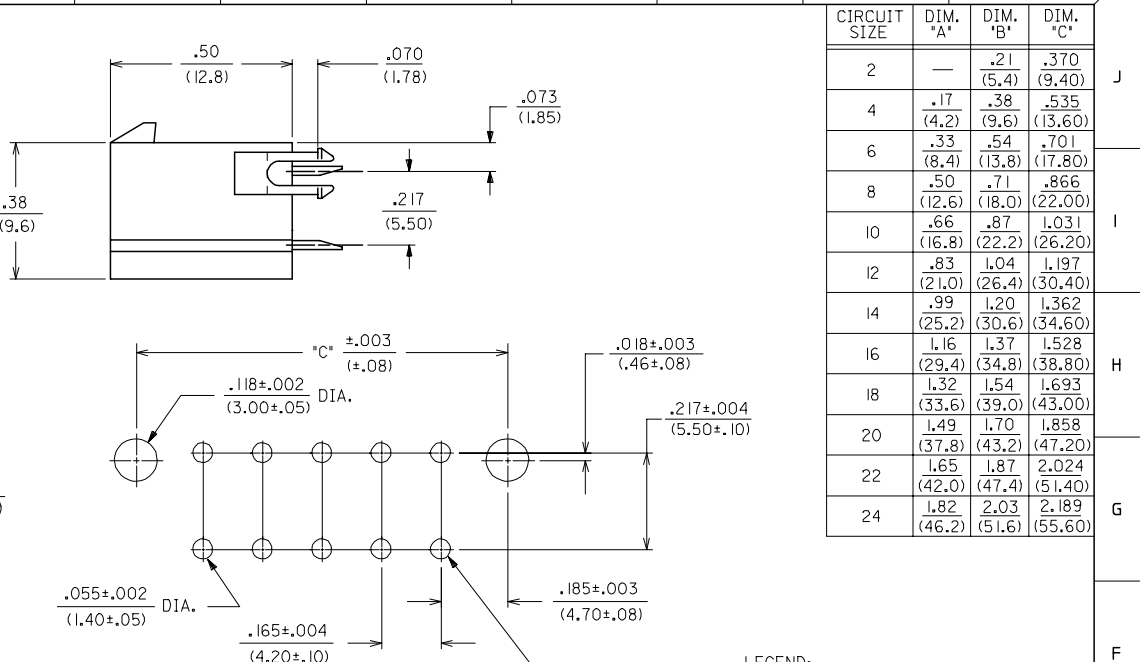
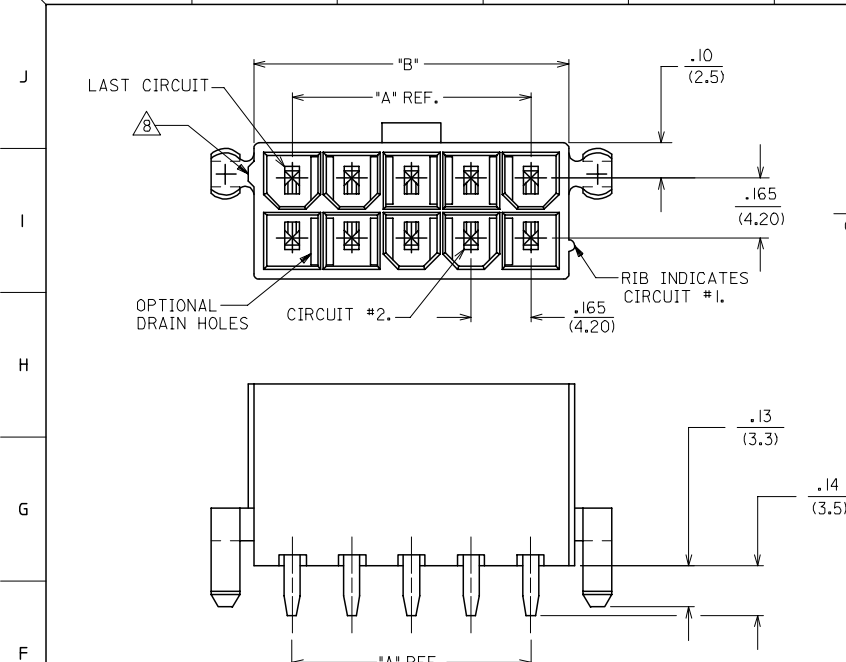

CIRCUIT SIZE	DIM. 'A'	DIM. 'B'	DIM. 'C'
2	—	.21 (5.4)	.370 (9.40)
4	.17 (4.2)	.38 (9.6)	.535 (13.60)
6	.33 (8.4)	.54 (13.8)	.701 (17.80)
8	.50 (12.6)	.71 (18.0)	.866 (22.00)
10	.66 (16.8)	.87 (22.2)	1.031 (26.20)
12	.83 (21.0)	1.04 (26.4)	1.197 (30.40)
14	.99 (25.2)	1.20 (30.6)	1.362 (34.60)
16	1.16 (29.4)	1.37 (34.8)	1.528 (38.80)
18	1.32 (33.6)	1.54 (39.0)	1.693 (43.00)
20	1.49 (37.8)	1.70 (43.2)	1.858 (47.20)
22	1.65 (42.0)	1.87 (47.4)	2.024 (51.40)
24	1.82 (46.2)	2.03 (51.6)	2.189 (55.60)

**NOTES:**

- HOUSING MATERIAL:  
 "BLANK" - NYLON 6/6, U.L. 94V-2, COLOR: NATURAL.  
 210 - NYLON 6/6, U.L. 94V-0, COLOR: NATURAL.  
 BL - NYLON 6/6, U.L. 94V-2, COLOR: DYED BLACK.
  - TERMINAL MATERIAL: BRASS ALLOY 260
  - PART MATES WITH MINI-FIT JR. RECEPTACLE #5557.
  - PACKAGING: SEE CHARTS
  - MOUNTING OPTIONS:  
 "BLANK" - NO MOUNTING (SEE SD-5566-NA AND -NB SERIES DWGS.)  
 2 - PEG MOUNT
  - TERMINAL PLATING:  
 "BLANK" - .000035/(.00090) MIN. TIN OVER .000020/(.00050) MIN. COPPER.  
 \*GS - .000030/(.00076) MIN. SELECT GOLD .000100/(.00254) MIN. SELECT MATTE TIN OVER .000050/(.00127) MIN. NICKEL OVERALL.  
 \*GS2 - .000015/(.00038) MIN. SELECT GOLD AND .000100/(.00254) MIN. SELECT MATTE TIN OVER .000050/(.00127) MIN. NICKEL OVERALL.  
 S - .000100/(.00254) MIN. TIN OVER .000050/(.00127) MIN. NICKEL.
- \*THE PRIMARY SHIPPING CARTON WILL BE LABELED 'COMPLIANT TO RoHS DIRECTIVE 2002/95/EC AND ELV ANNEX II OF DIRECTIVE 2000/53/EC.'  
 \*CARTONS WITHOUT THIS LABEL MAY CONTAIN PRODUCT WITH TIN-LEAD PLATING.
- PRODUCT SPECIFICATION AND PROCESSING PARAMETERS: SEE PS-5556-001
  - ANTI-SHINGLING RIB MAY OR MAY NOT APPEAR ON HOUSINGS.
  - CONNECTORS ARE NOT TO BE MATED OR UNMATED WHILE CIRCUITS ARE LIVE.
  - PARTS ARE NOT DESIGNED FOR CURRENT SHARING.

RECOMMENDED HOLE LAYOUT FOR .070/(1.78) MAX. THICK P. C. BOARD  
 VIEWED FROM COMPONENT SIDE

**LEGEND:**

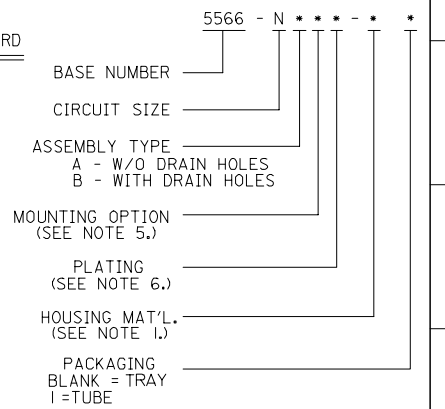

4	Q
3	Q
2	Q
1	R1
SHT. REV.	

REVISED NOTES 8 EC NO: UICP2006-2601 DRAWN: ADRIAN NOL 2006/05/11 CHK'D: POLGAR 2006/05/13 APPR: ICOMERCJ 2006/05/15 R1	QUALITY SYMBOLS ▽=0 ▽=0	GENERAL TOLERANCES (UNLESS SPECIFIED) mm INCH 4 PLACES ± --- ± --- 3 PLACES ± --- ± .015 2 PLACES ± 0.38 ± --- 1 PLACE ± --- ± --- ANGULAR ±1/2°	DIMENSION STYLE IN/MM DRAWN BY DATE RJF 8/19/87 CHECKED BY DATE GT 8/19/87 APPROVED BY DATE RAS 8/19/87	SCALE 4:1 DESIGN UNITS METRIC THIRD ANGLE PROJECTION	TITLE MINI-FIT JR. VERTICAL HEADER ASSEMBLIES WITH MOUNTING PEGS MOLEX MOLEX INCORPORATED	SHEET NO. 1 OF 4
		DRAFT WHERE APPLICABLE MUST REMAIN WITHIN DIMENSIONS	MATERIAL NO. SEE SHTS 2-4	DOCUMENT NO. SDA-5566-N*2*-*	THIS DRAWING CONTAINS INFORMATION THAT IS PROPRIETARY TO MOLEX INCORPORATED AND SHOULD NOT BE USED WITHOUT WRITTEN PERMISSION	

