

Distributed by:

JAMECO[®]
ELECTRONICS

www.Jameco.com ♦ 1-800-831-4242

The content and copyrights of the attached
material are the property of its owner.

Jameco Part Number 882904

FEATURES AND SPECIFICATIONS

Features and Benefits

- Positive latching to mating headers or plugs
- Fully isolated contacts
- Fully polarized to mating headers and plugs
- Integral pull tabs for ease in unmating

Physical

Housing: Polyester, UL 94V-0

Reference Information

Product Specification: PS-43045

Packaging: Bag

UL File No.: E29179

CSA File No.: LR19980

TUV License No.: R95107

Mates With: [43020](#) and [43045](#)

Use With: [43030](#)

Designed In: Millimeters

molex® 3.00mm (.118") Pitch Micro-Fit 3.0™ Wire-to-Wire Receptacle

43025 Dual Row

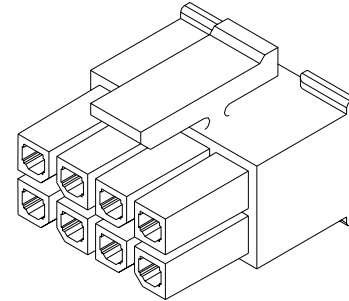

Power Connectors

F

CATALOG DRAWING (FOR REFERENCE ONLY)

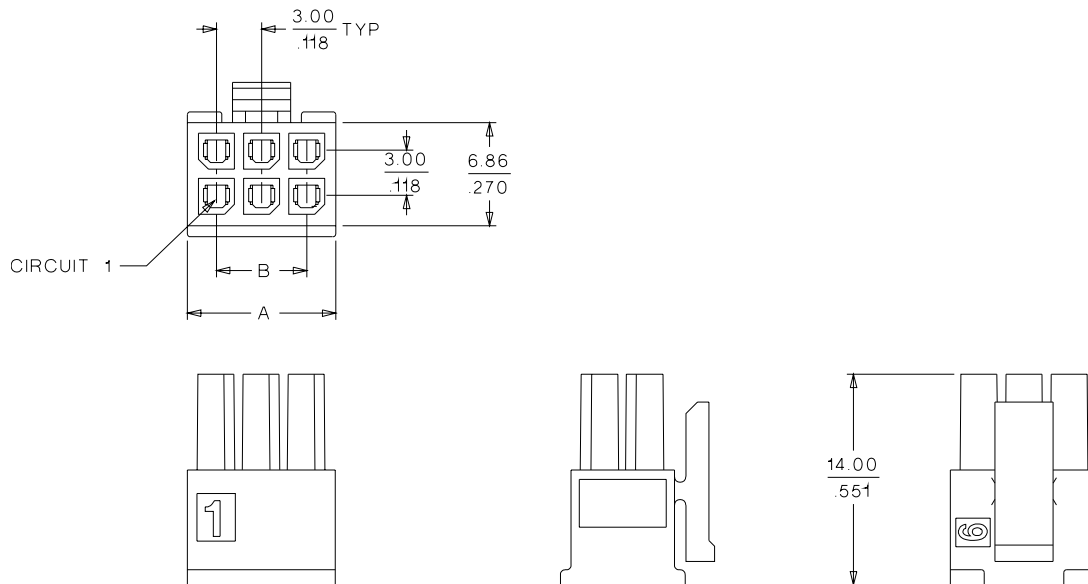

ORDERING INFORMATION AND DIMENSIONS

Circuits	Order No.	Dimension	
		A	B
2	• 43025-0200	3.85 (.152)	
4	• 43025-0400	6.85 (.270)	3.00 (.118)
6	• 43025-0600	9.85 (.388)	6.00 (.236)
8	• 43025-0800	12.85 (.506)	9.00 (.354)
10	• 43025-1000	15.85 (.624)	12.00 (.472)
12	• 43025-1200	18.85 (.742)	15.00 (.591)
14	• 43025-1400	21.85 (.860)	18.00 (.709)
16	• 43025-1600	24.85 (.978)	21.00 (.827)
18	• 43025-1800	27.85 (1.096)	24.00 (.945)
20	• 43025-2000	30.85 (1.215)	27.00 (1.063)
22	• 43025-2200	33.85 (1.333)	30.00 (1.181)
24	• 43025-2400	36.85 (1.451)	33.00 (1.299)

• US Standard Product, available through Molex franchised distributors



PRODUCT SPECIFICATION

MICRO-FIT

1.0 SCOPE

This Product Specification covers the 3.00 mm (.118 inch) centerline (pitch) square pin headers when mated with either printed circuit board (PCB) connector or connectors terminated with 20 to 30 AWG wire using crimp technology.

2.0 PRODUCT DESCRIPTION

2.1 PRODUCT NAME AND SERIES NUMBERS

Receptacle: 43025 Terminal: 43030
Plug: 43020 Terminal: 43031
Headers: 43045, 44914

Test Plug: 44242 (recommended for continuity testing only)

Other products conforming to this specification are noted on the individual drawings.

2.2 DIMENSIONS, MATERIALS, PLATINGS AND MARKINGS

Housings: Polyester or LCP
Terminal: Phosphor Bronze
Pins: Brass, Modified Tin/Brass

2.3 SAFETY AGENCY APPROVALS

UL File Number: E29179
CSA: LR19980
TUV: 72040445

3.0 APPLICABLE DOCUMENTS AND SPECIFICATIONS

Test Summary: TS-43045-001

4.0 RATINGS

4.1 VOLTAGE

UL: 250 Volts AC (MAX) {or 176 Volts DC}
TUV: 250 Volts

4.2 CURRENT AND APPLICABLE WIRES (Current is dependent on connector size, contact material, plating, ambient temperature, printed circuit board characteristics and related factors. Actual current rating is application dependent and should be evaluated for each application.)

AWG	Amps	Max. Outside Insulation Diameter
20	5	1.85 mm (.073 inch)
22	5	1.85 mm (.073 inch)
24	4	1.85 mm (.073 inch)
26	3	1.27 mm (.050 inch)
28	2	1.27 mm (.050 inch)
30	1	1.27 mm (.050 inch)

4.2.1 CURRENT FOR TEST PLUG 44242

2.5 Amps Maximum (Pogo pin current capacity)

(Test plugs are for testing purposes only and not intended for continuous use.)

4.3 TEMPERATURE

Operating: - 40°C to + 105°C (Including Terminal Temperature Rise)

Nonoperating: - 40°C to + 105°

REVISION: K	EGR/ECN INFORMATION: EC No: UCP2007-0365 DATE: 2006/08/08	TITLE: PRODUCT SPECIFICATION MICRO-FIT DUAL ROW CONNECTORS	SHEET No. 1 of 5
DOCUMENT NUMBER: PS-43045	CREATED / REVISED BY: M.KIPPER	CHECKED BY: S.SOUSEK	APPROVED BY: F.SMITH



PRODUCT SPECIFICATION

5.0 PERFORMANCE

5.1 ELECTRICAL REQUIREMENTS

DESCRIPTION	TEST CONDITION	REQUIREMENT
Contact Resistance (Low Level)	Mate connectors: apply a maximum voltage of 20 mV and a current of 100 mA. (Does not include wire resistance)	10 milliohms MAXIMUM [initial]
Contact Resistance @ Rated Current	Mate connectors: apply a maximum voltage of 20 mV at rated current.	30 milliohms MAXIMUM [initial]
Contact Resistance of Wire Termination (Low Level)	Terminate the applicable wire to the terminal and measure wire using a voltage of 20 mV and a current of 100 mA.	5 milliohms MAXIMUM [initial]
Insulation Resistance	Unmate & unmount connectors: apply a voltage of 500 VDC between adjacent terminals and between terminals to ground.	1000 Megohms MINIMUM
Dielectric Withstanding Voltage	Unmate connectors: apply a voltage of {two times the rated voltage plus 1000 volts} VAC for 1 minute between adjacent terminals and between terminals to ground.	No breakdown; current leakage < 5 mA
Capacitance	Measure between adjacent terminals at 1 MHz.	2 picofarads MAXIMUM
Temperature Rise (via Current Cycling)	Mate connectors: measure the temperature rise at the rated current after: 1) 96 hours (steady state) 2) 240 hours (45 minutes ON and 15 minutes OFF per hour) 3) 96 hours (steady state)	Temperature rise: +30°C MAXIMUM

5.2 MECHANICAL REQUIREMENTS

DESCRIPTION	TEST CONDITION	REQUIREMENT
Connector Mate and Unmate Forces	Mate and unmate connector (male to female) at a rate of 25 ± 6 mm (1 ± ¼ inch) per minute. (Per circuit)	8.0 N (1.8 lbf) MAXIMUM insertion force & 3.7 N (0.8 lbf) MINIMUM withdrawal force
Terminal Retention Force (in Housing)	Axial pullout force on the terminal in the housing at a rate of 25 ± 6 mm (1 ± ¼ inch) per minute.	24.5 N (5.5 lbf) MINIMUM retention force
Terminal Insertion Force (into Housing)	Apply an axial insertion force on the terminal at a rate of 25 ± 6 mm (1 ± ¼ inch).	14.7 N (3.3 lbf) MAXIMUM insertion force

REVISION: K	EGR/ECN INFORMATION: EC No: UCP2007-0365 DATE: 2006/08/08	TITLE: PRODUCT SPECIFICATION MICRO-FIT DUAL ROW CONNECTORS	SHEET No. 2 of 5
DOCUMENT NUMBER: PS-43045	CREATED / REVISED BY: M.KIPPER	CHECKED BY: S.SOUSEK	APPROVED BY: F.SMITH



PRODUCT SPECIFICATION

5.2 MECHANICAL REQUIREMENTS

Durability	Mate connectors up to 30 cycles at a maximum rate of 10 cycles per minute prior to Environmental Tests.	20 milliohms MAXIMUM (change from initial)
Vibration (Random)	Mate connectors and vibrate per EIA 364-28, test condition VII.	20 milliohms MAXIMUM (change from initial) & Discontinuity < 1 microsecond
Shock (Mechanical)	Mate connectors and shock at 50 g's with ½ sine wave (11 milliseconds) shocks in the ±X,±Y,±Z axes (18 shocks total).	20 milliohms MAXIMUM (change from initial) & Discontinuity < 1 microsecond
Wire Pullout Force (Axial) (Wire from Terminal)	Apply an axial pullout force on the wire at a rate of 25 ± 6 mm (1 ± ¼ inch).	MINIMUM pullout force 20 awg: 57.8 N (13.0 lbf) 22 awg: 35.6 N (8.0 lbf) 24 awg: 22.2 N (5.0 lbf) 26 awg: 13.3 N (3.0 lbf) 28 awg: 8.9 N (2.0 lbf) 30 awg: 6.6 N (1.5 lbf)
Normal Force	Apply a perpendicular force.	2.7 N (275 grams) MINIMUM
Pin to Header Retention	Apply axial push force to pin at a rate of 25 ± 6 mm (1 ± ¼ inch) per minute.	13.7 N (3.1 lbf) MINIMUM pushout force
Thumb Latch to Ramp Yield Strength	Full mate and then Unmate the connectors at a rate of 25 ± 6 mm (1 ± ¼ inch) per minute.	68.4 N (15.4 lbf) MINIMUM Yield Strength
Panel Mount Retention	Full mate and then Unmate the connectors at a rate of 25 ± 6 mm (1 ± ¼ inch) per minute.	155.7 N (35 lbf) MINIMUM pushout force
Compliant Pin Insertion Force into PCB Hole (44914 Series)	Apply an axial insertion force on the terminal at a rate of 25 ± 6 mm (1 ± ¼ inch).	106.7 N (24 lbf) MAXIMUM Insertion force (Per Terminal)
Compliant Pin Retention Force in PCB Hole (44914 Series)	Apply an axial extraction force on the terminal at a rate of 25 ± 6 mm (1 ± ¼ inch).	35.6 N (8 lbf) MINIMUM Retention force (Per Terminal)

REVISION: K	EGR/ECN INFORMATION: EC No: UCP2007-0365 DATE: 2006/08/08	TITLE: PRODUCT SPECIFICATION MICRO-FIT DUAL ROW CONNECTORS	SHEET No. 3 of 5
DOCUMENT NUMBER: PS-43045	CREATED / REVISED BY: M.KIPPER	CHECKED BY: S.SOUSEK	APPROVED BY: F.SMITH



PRODUCT SPECIFICATION

5.3 ENVIRONMENTAL REQUIREMENTS

DESCRIPTION	TEST CONDITION	REQUIREMENT
Thermal Aging	Mate connectors; expose to: 240 hours at 105 ± 2°C OR 500 hours at 85 ± 2°C	20 milliohms MAXIMUM (change from initial)]
Humidity (Steady State)	Mate connectors: expose to a temperature of 40 ± 2°C with a relative humidity of 90-95% for 96 hours. Note: Remove surface moisture and air dry for 1 hour prior to measurements.	20 milliohms MAXIMUM (change from initial) & Dielectric Withstanding Voltage: No Breakdown at 500 VAC & Insulation Resistance: 1000 Megohms MINIMUM
Solderability	Per SMES-152	Solder coverage: 95% MINIMUM (per SMES-152)
Solder Resistance	A) Wave Solder Process Dip connector terminal tails in solder; Solder Duration: 5 ± 0.5 seconds; Solder Temperature: 260°C MAX B) Convection Reflow Solder Process 235°C MAX Per SMES-152	Visual: No Damage to insulator material
Cold Resistance	Mate connectors: Duration: 96 hours; Temperature: -40 ± 3°C	20 milliohms MAXIMUM (change from initial)
Corrosive Atmosphere: Sulfur Dioxide Gas (SO₂)	Mate connectors: Duration: 24 hours exposure; Atmosphere: 50 parts per million (ppm) SO ₂ gas; Temperature: 40 ± 3°C	20 milliohms MAXIMUM (change from initial)
Corrosive Atmosphere: Ammonia Gas (NH₃)	Mate connectors: Duration: 40 minutes exposure; Atmosphere: NH ₃ gas evaporating from a 28% Ammonia solution	20 milliohms MAXIMUM (change from initial)

REVISION: K	ECR/ECN INFORMATION: EC No: UCP2007-0365 DATE: 2006/08/08	TITLE: PRODUCT SPECIFICATION MICRO-FIT DUAL ROW CONNECTORS	SHEET No. 4 of 5
DOCUMENT NUMBER: PS-43045	CREATED / REVISED BY: M.KIPPER	CHECKED BY: S.SOUSEK	APPROVED BY: F.SMITH



PRODUCT SPECIFICATION

6.0 PACKAGING

Parts shall be packaged to protect against damage during handling, transit and storage per the packaging specifications listed below:

Receptacle: PK-43025-001

Plug: PK-43020-001

Headers: PK-70873-0313, PK-70873-0314, PK-70873-05**.

7.0 GAGES AND FIXTURES

It is recommended that test plugs (Series 44242) be used for continuity testing of receptacles. Standard mating parts should not be used for harness testing.

8.0 OTHER INFORMATION

8.1 CABLE TIE AND OR WIRE TWIST LOCATION

CKT Sizes	Dim T	Min.
2-8	.500	(12.70)
10-16	.750	(19.10)
18-24	1.000	(25.40)

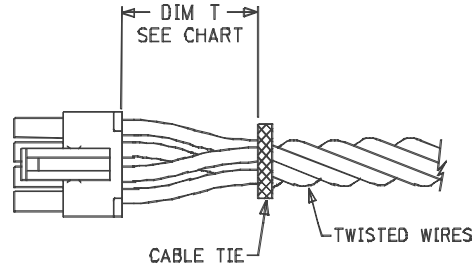

REVISION: K	EGR/ECN INFORMATION: EC No: UCP2007-0365 DATE: 2006/08/08	TITLE: PRODUCT SPECIFICATION MICRO-FIT DUAL ROW CONNECTORS	SHEET No. 5 of 5
DOCUMENT NUMBER: PS-43045	CREATED / REVISED BY: M.KIPPER	CHECKED BY: S.SOUSEK	APPROVED BY: F.SMITH

