

CKTS	A	B	C
02	.262 6.65	NA	.441 11.20
04	.380 9.65	.118 3.00	.559 14.20
06	.498 12.65	.236 6.00	.677 17.20
08	.616 15.65	.354 9.00	.795 20.20
10	.734 18.65	.472 12.00	.913 23.20
12	.852 21.65	.591 15.00	1.031 26.20
14	.970 24.65	.709 18.00	1.150 29.20
16	1.088 27.65	.827 21.00	1.268 32.20
18	1.206 30.65	.945 24.00	1.386 35.20
20	1.325 33.65	1.063 27.00	1.504 38.20
22	1.443 36.65	1.181 30.00	1.622 41.20
24	1.561 39.65	1.299 33.00	1.740 44.20

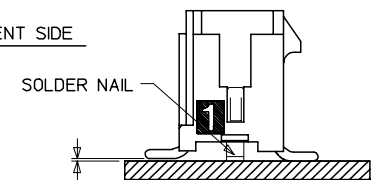
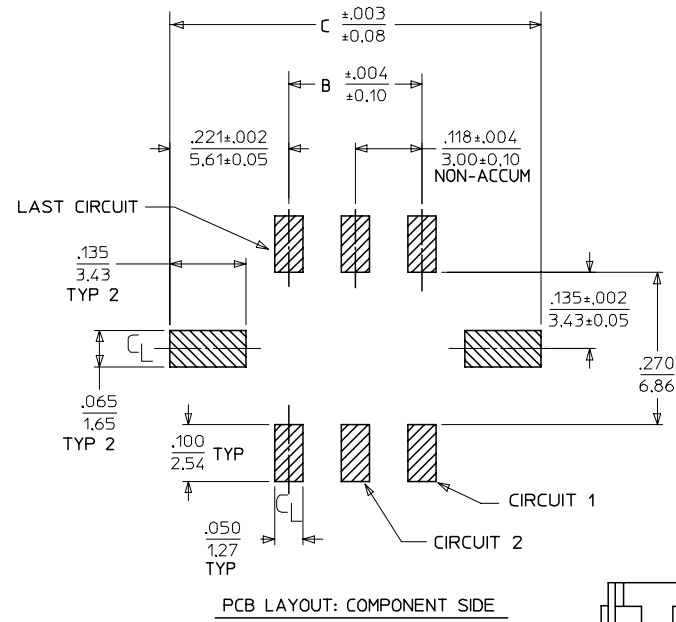
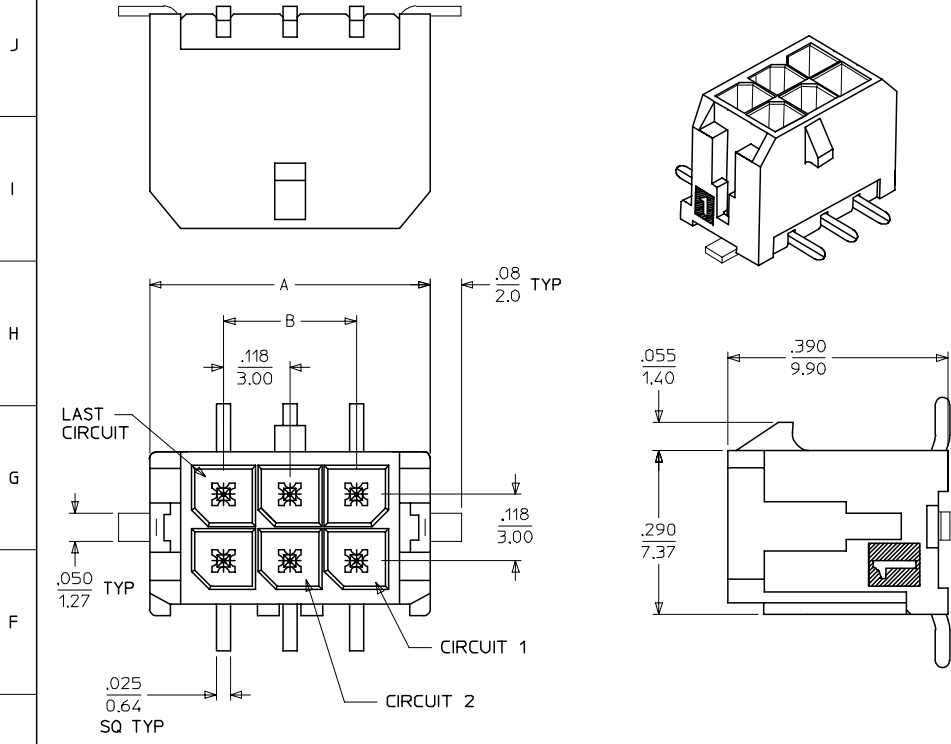

COPLANARITY DETAIL
SEE NOTE #6

SHOWN WITH DISPOSABLE CAP
(FOR REMOVAL FROM TAPE & REEL PACKAGING)
SEE NOTE #5

NOTES:

- HOUSING MATERIAL: GLASS FILLED LIQUID CRYSTAL POLYMER
UL94V-0. COLOR: BLACK
TERMINAL MATERIAL: BRASS ALLOY
- FINISH:
A = .000100/(0.00254) MIN. TIN OVER
.000050/(0.00127) MIN. NICKEL PLATE.
B = .000015/(0.00038) MIN. SELECT GOLD IN CONTACT AREA,
.000100/(0.00254) MIN. SELECT TIN ON SOLDER TAILS,
BOTH OVER .000050/(0.00127) MIN. NICKEL PLATE.
C = .000030/(0.00076) MIN. SELECT GOLD IN CONTACT AREA,
.000100/(0.00254) MIN. SELECT TIN ON SOLDER TAILS,
BOTH OVER .000050/(0.00127) MIN. NICKEL PLATE.
* THE PRIMARY SHIPPING CARTON WILL BE LABELED 'COMPLIANT TO
RoHS DIRECTIVE 2002/95/EC AND ELV ANNEX II OF DIRECTIVE 2000/53/EC.'
CARTONS WITHOUT THIS LABEL MAY CONTAIN PRODUCT WITH TIN/LEAD
IN THE PC TAIL AREA.
- PRODUCT SPECIFICATION: PS-43045
- MATES WITH MICRO FIT (3.0) RECEPTACLE SERIES 43025
- TAPE AND REEL PACK : SEE MOLEX DRAWING PK-70873-05**
- THE COPLANARITY DIMENSION IS ESTABLISHED BY PLACING THE ASSEMBLY
ON A FLAT SURFACE. THE DISTANCE FROM THAT SURFACE TO THE BOTTOM
OF ANY TERMINAL OR SOLDER NAIL MUST NOT EXCEED .006/0.15

	FINISH A	FINISH B	FINISH C
CKTS	MATERIAL NO:	MATERIAL NO:	MATERIAL NO:
02	43045-0218	43045-0219	43045-0220
04	43045-0418	43045-0419	43045-0420
06	43045-0618	43045-0619	43045-0620
08	43045-0818	43045-0819	43045-0820
10	43045-1018	43045-1019	43045-1020
12	43045-1218	43045-1219	43045-1220
14	43045-1418	43045-1419	43045-1420
16	43045-1618	43045-1619	43045-1620
18	43045-1818	43045-1819	43045-1820
20	43045-2018	43045-2019	43045-2020
22	43045-2218	43045-2219	43045-2220
24	43045-2418	43045-2419	43045-2420

LEAD FREE EC NO: UCP2004-1223 DRWN: JERNY 2004/03/12 CHKD: 2004/03/31 APPR: FSMITH 2004/04/05 REV DESCRIPTION	QUALITY SYMBOLS	GENERAL TOLERANCES (UNLESS SPECIFIED)	SCALE ---	DESIGN UNITS METRIC	THIRD ANGLE PROJECTION	REVISE ON CAD ONLY
	▽ = 0 ▽ = 0	4 PLACES ± --- ± --- 3 PLACES ± --- ± .010 2 PLACES ± 0.25 ± .014 1 PLACE ± 0.36 ± --- ANGULAR ±1/2°	DIMENSION STYLE IN/MM DRAWN BY SAMIEC DATE 2000/03/15 CHECKED BY MUELLER DATE 2000/03/15 APPROVED BY EDGLEY DATE 2000/03/15	TITLE	MICRO FIT (3.0) DUAL ROW VERTICAL SMT HEADER W/VERTICAL ASSY MOLEX MOLEX INCORPORATED	
		DRAFT WHERE APPLICABLE MUST REMAIN WITHIN DIMENSIONS	THIS DRAWING CONTAINS INFORMATION THAT IS PROPRIETARY TO MOLEX INCORPORATED AND SHOULD NOT BE USED WITHOUT WRITTEN PERMISSION	MATERIAL NO. SEE CHART	DOCUMENT NO. SD-43045-007	SHEET NO. 1 OF 1