

	13	12	11	10	9	8	7	6	5	4	3	2
	MATERIAL NUMBER	NUMBER OF POSITIONS	PLATING OPTION	NUMBER OF POSITIONS	DIM. 'A'	DIM. 'B'	DIM. 'C'					
J	44764-0401	04	A	24	1.445/(36.70)	1.299/(33.00)	1.181/(30.00)					
	44764-0402	04	B	22	1.327/(33.70)	1.181/(30.00)	1.063/(27.00)					
	44764-0403	04	C	20	1.209/(30.70)	1.063/(27.00)	0.945/(24.00)					
	44764-0601	06	A	18	1.091/(27.70)	0.945/(24.00)	0.827/(21.00)					
	44764-0602	06	B	16	0.972/(24.70)	0.827/(21.00)	0.709/(18.00)					
	44764-0603	06	C	14	0.854/(21.70)	0.709/(18.00)	0.591/(15.00)					
I	44764-0801	08	A	12	0.736/(18.70)	0.591/(15.00)	0.472/(12.00)					
	44764-0802	08	B	10	0.618/(15.70)	0.472/(12.00)	0.354/(9.00)					
	44764-0803	08	C	8	0.500/(12.70)	0.354/(9.00)	0.236/(6.00)					
	44764-1001	10	A	6	0.382/(9.70)	0.236/(6.00)						
	44764-1002	10	B	4	0.264/(6.70)	0.118/(3.00)						
	44764-1003	10	C									
	44764-1201	12	A									
	44764-1202	12	B									
	44764-1203	12	C									
H	44764-1401	14	A									
	44764-1402	14	B									
	44764-1403	14	C									
	44764-1601	16	A									
	44764-1602	16	B									
	44764-1603	16	C									
	44764-1801	18	A									
	44764-1802	18	B									
	44764-1803	18	C									
G	44764-2001	20	A									
	44764-2002	20	B									
	44764-2003	20	C									
	44764-2201	22	A									
	44764-2202	22	B									
	44764-2203	22	C									
	44764-2401	24	A									
F	44764-2402	24	B									
	44764-2403	24	C									

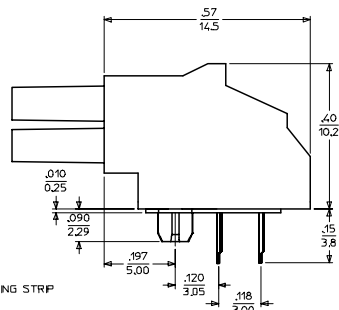
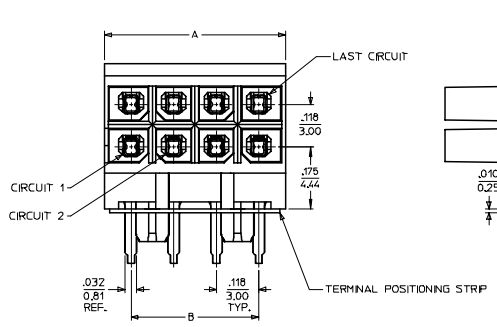
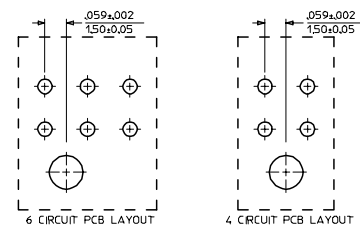
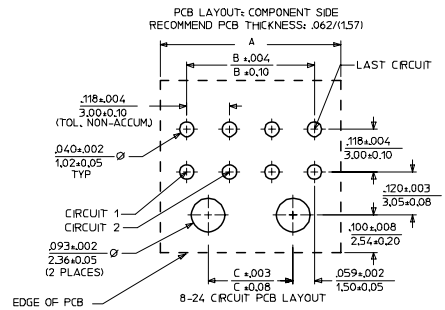
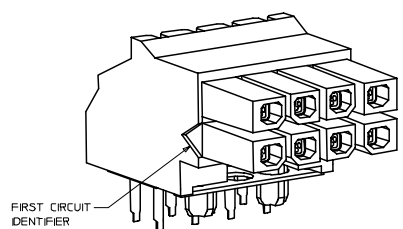
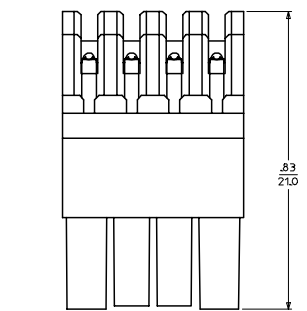

- NOTES:
- MATERIAL: HOUSINGS: HIGH TEMP NYLON, GLASS FILLED, UL, 94V-0, COLOR BLACK. TERMINAL: PHOSPHOR BRONZE ALLOY. POSITIONING STRIP: MYLAR, COLOR NATURAL.
 - FINISH: (A) - HOT TIN DIP: .000040/0.00102 MIN. (B) - SELECTIVE GOLD IN THE CONTACT AREA: .000015/0.00039 MIN. SELECTIVE TIN IN THE PC TAIL AREA: .000100/0.00254 MIN. BOTH OVER .000050/0.00127 MIN. NICKEL. (C) - SELECTIVE GOLD IN THE CONTACT AREA: .000030/0.00076 MIN. SELECTIVE TIN IN THE PC TAIL AREA: .000100/0.00254 MIN. BOTH OVER .000050/0.00127 MIN. NICKEL. * THE PRIMARY SHIPPING CARTON WILL BE LABELED 'COMPLIANT TO RoHS DIRECTIVE 2002/95/EC AND ELV ANNEX II OF DIRECTIVE 2000/53/EC'. CARTONS WITHOUT THIS LABEL MAY CONTAIN PRODUCT WITH TIN/LEAD IN THE PC TAIL AREA.
 - PRODUCT SPECIFICATIONS: PS-44300-001
 - PACKAGING SPECIFICATION: PER MOLEX DRAWING PK-44764-001
 - MATES WITH HEADER ASSEMBLY 44428, 44432, AND 44300
 - MOLEX RECOMMENDS THE USE OF MICRO-FIT TEST PLUG (SERIES 44242) WHENEVER CONTINUITY TESTING IS PERFORMED. TEST PLUGS MUST NOT BE USED TO MAKE OR BREAK UNDER LOAD. MOLEX DOES NOT RECOMMEND USING STANDARD MATING COMPONENTS (SERIES 44428, 44432, OR 44300) FOR TESTING PURPOSES.

ADD MATING DIMENSION FC NO: UCP2005-2881 DRWN: JLOWE 2005/07/07 CHKD: SSOUSEK 2005/07/13 APPR: FSMITH 2005/07/15	QUALITY SYMBOLS - 0 - 0	GENERAL TOLERANCES (UNLESS SPECIFIED)		SCALE	DESIGN UNITS	THIRD ANGLE PROJECTION	REVISE ON CAD ONLY
		mm	INCH	---	INCH		
		DIMENSION STYLE		IN/MM			
		4 PLACES ± --- ± ---	3 PLACES ± --- ± .010	DRAWN BY	DATE		
2 PLACES ± 0.25 ± .014	1 PLACE ± 0.35 ± ---	BURLESON	2000/07/13	TITLE		MICRO-FIT (3.0) BMI R/A RECEPTACLE ASS'Y 4 - 24 CIRCUIT	
ANGULAR ±1/2°	DRAFT WHERE APPLICABLE	MUELLER	2000/07/13	CHECKED BY	DATE	molex MOLEX INCORPORATED	
MUST REMAIN WITHIN DIMENSIONS		APPROVED BY	DATE	EDGLEY	2000/07/13	MATERIAL NO.	DOCUMENT NO.
		THIS DRAWING CONTAINS INFORMATION THAT IS PROPRIETARY TO MOLEX INCORPORATED AND SHOULD NOT BE USED WITHOUT WRITTEN PERMISSION		SEE CHART		SD-44764-001	SHEET NO. 1 OF 1

MATERIAL NUMBER	NUMBER OF POSITIONS	PLATING OPTION
	04	A
	04	B
	04	C
	06	A
	06	B
	06	C
	08	A
	08	B
	08	C
	10	A
44764-1022	10	B
	10	C
	12	A
	12	B
	12	C
	14	A
	14	B
	14	C
	16	A
	16	B
	16	C
	18	A
	18	B
	18	C
	20	A
	20	B
	20	C
	22	A
	22	B
	22	C
	24	A
	24	B
	24	C

NUMBER OF POSITIONS	DIM. "A"	DIM. "B"	DIM. "C"
24	1.445/(36.70)	1.299/(33.00)	1.181/(30.00)
22	1.327/(33.70)	1.181/(30.00)	1.063/(27.00)
20	1.209/(30.70)	1.063/(27.00)	.945/(24.00)
18	1.091/(27.70)	.945/(24.00)	.827/(21.00)
16	.972/(24.70)	.827/(21.00)	.709/(18.00)
14	.854/(21.70)	.709/(18.00)	.591/(15.00)
12	.736/(18.70)	.591/(15.00)	.472/(12.00)
10	.618/(15.70)	.472/(12.00)	.354/(9.00)
8	.500/(12.70)	.354/(9.00)	.236/(6.00)
6	.382/(9.70)	.236/(6.00)	
4	.264/(6.70)	.118/(3.00)	

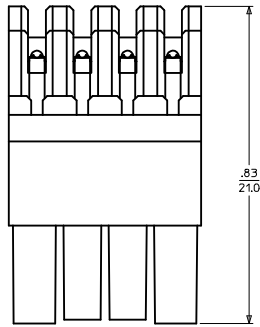

FIRST CIRCUIT IDENTIFIER

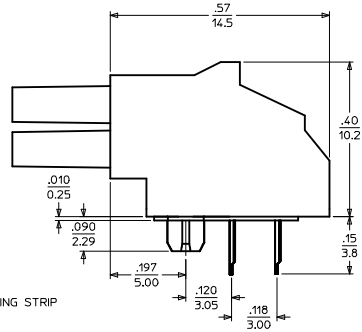
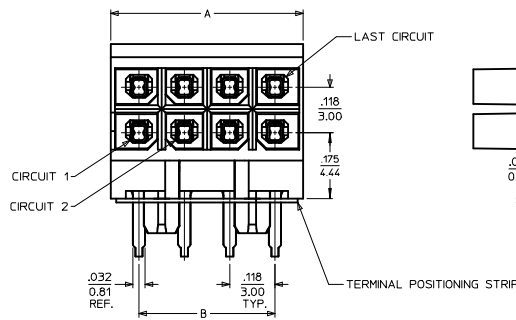
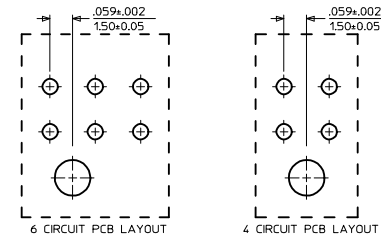
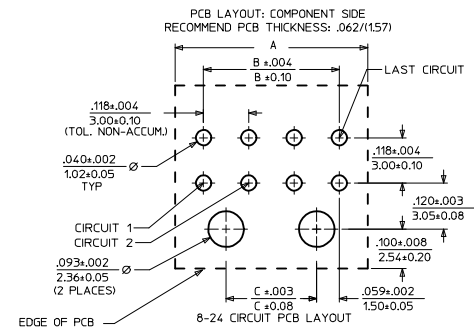
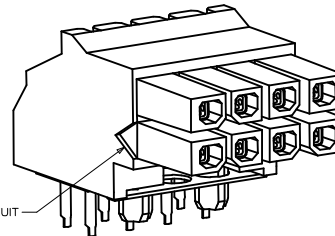

- NOTES:
- MATERIAL:
HOUSING: HIGH TEMP NYLON, GLASS FILLED, U.L. 94V-0, COLOR BLACK
TERMINAL: PHOSPHOR BRONZE ALLOY
POSITIONING STRIP: NYLAR, COLOR NATURAL
 - FINISH:
(A) = HOT TIN DIP: .00040/0.00102 MIN.
(B) = SELECTIVE GOLD IN THE CONTACT AREA: .000015/0.00039 MIN., SELECTIVE TIN IN THE PC TAIL AREA: .000100/0.00254 MIN., BOTH OVER .000050/0.00127 MIN. NICKEL.
(C) = SELECTIVE GOLD IN THE CONTACT AREA: .000030/0.00076 MIN., SELECTIVE TIN IN THE PC TAIL AREA: .000100/0.00254 MIN., BOTH OVER .000050/0.00127 MIN. NICKEL.
 - PRODUCT SPECIFICATIONS: PS-44300-001
 - PACKAGING SPECIFICATION: TUBE PACKED PER PK-44764-002
 - MATES WITH HEADER ASSEMBLY 44428, 44432, AND 44300
 - MOLEX RECOMMENDS THE USE OF MICRO-FIT TEST PLUG (SERIES 44242) WHENEVER CONTINUITY TESTING IS PERFORMED. TEST PLUGS MUST NOT BE USED TO MAKE OR BREAK UNDER LOAD. MOLEX DOES NOT RECOMMEND USING STANDARD MATING COMPONENTS (SERIES 44428, 44432, OR 44300) FOR TESTING PURPOSES.

INITIAL RELEASE EC NO: UCP2009-0615 DRWN:GAVERRILL 2008/09/15 CHKD:SSOUSEK 2008/09/16 APPR:FSMITH 2008/09/16	QUALITY SYMBOLS ▽ - 0 ∇ - 0	GENERAL TOLERANCES (UNLESS SPECIFIED)	SCALE	DESIGN UNITS	THIRD ANGLE PROJECTION	REVISE ON CAD ONLY
			---	INCH		
			DIMENSION STYLE			
			IN/MM			
REV	DESCRIPTION	4 PLACES ± --- ± ---	DRAWN BY	DATE	TITLE MICRO-FIT (3.0) BMI R/A RECEPTACLE ASS'Y 4 - 24 CKT, TUBE PACKED	SHEET NO. 1 OF 1
		3 PLACES ± --- ± .010	GAVERRILL	2008/09/11		
		2 PLACES ± 0.25 ± .014	CHECKED BY	DATE		
		1 PLACE ± 0.35 ± ---	SSOUSEK	2008/09/11		
ANGULAR ±1/2°		APPROVED BY	DATE	MATERIAL NO.	DOCUMENT NO.	
DRAFT WHERE APPLICABLE		FSMITH	2008/09/15	SEE CHART	SD-44764-003	
MUST REMAIN WITHIN DIMENSIONS		THIS DRAWING CONTAINS INFORMATION THAT IS PROPRIETARY TO MOLEX INCORPORATED AND SHOULD NOT BE USED WITHOUT WRITTEN PERMISSION				