

Distributed by:

**JAMECO**<sup>®</sup>  
ELECTRONICS

**www.Jameco.com ♦ 1-800-831-4242**

The content and copyrights of the attached  
material are the property of its owner.

Jameco Part Number 1932125

## 2.00mm (.079") Pitch Wire-to-Board Crimp Terminal

**50212**

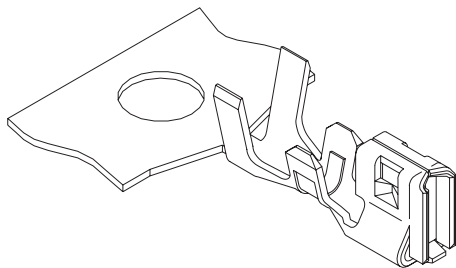

Order No.	Terminal	Lead-free
<a href="#">50212-8000</a>	Reel	Yes
<a href="#">50212-8100</a>	Bag	

### Features and Benefits

- Locking tang provides terminal retention to housing

### Reference Information

Packaging: Reel or bag  
 Use With: 35507, 51065, 51089, 51090 and 87369 housings  
 Designed In: Millimeters

### Electrical

Voltage: 125V  
 Current:

AWG	24	26	28	30
	2.0A	1.5A	1.0A	0.5A

Contact Resistance: 20 milliohms max.  
 Dielectric Withstanding Voltage: 500V AC/1 min.  
 Insulation Resistance: 1000 Megohms min.

### Physical

Contact: Phosphor Bronze  
 Plating: Tin  
 Wire Range: 24 to 30 AWG  
 Insulation Range: 1.40mm dia. max.  
 Strip Length: 1.3 to 1.8mm  
 Operating Temperature: -40 to +105°C

[www.molex.com/customer.html?seriesNumber=50212](http://www.molex.com/customer.html?seriesNumber=50212)

## 2.00mm (.079") Pitch Micro-Latch™ Wire-to-Board Housing

**51065**

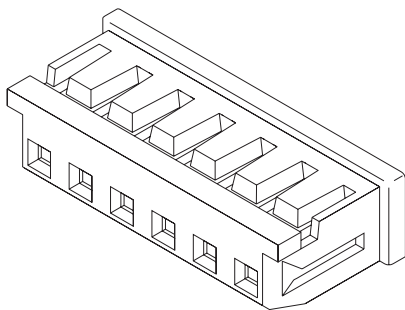

### Features and Benefits

- Sizes 2 to 15 circuits
- Housing lance provides extra terminal retention
- Friction lock provides secure mating

### Reference Information

Packaging: Bag  
 UL File No.: E29179  
 CSA File No.: LR19980  
 Mates With: 53253 and 53254  
 Use With: 50212  
 Designed In: Millimeters

### Electrical

Voltage: 125V  
 Current:

AWG	24	26	28	30
	2.0A	1.5A	1.0A	0.5A

Contact Resistance: 20 milliohms max.  
 Dielectric Withstanding Voltage: 500V AC/1 min.  
 Insulation Resistance: 1000 Megohms min.

### Physical

Housing: PBTP, UL 94V-0  
 Operating Temperature: -40 to +85°C

Circuits	Order No.
2	<a href="#">51065-0200</a>
3	<a href="#">51065-0300</a>
4	<a href="#">51065-0400</a>
5	<a href="#">51065-0500</a>
6	<a href="#">51065-0600</a>

Circuits	Order No.
7	<a href="#">51065-0700</a>
8	<a href="#">51065-0800</a>
9	<a href="#">51065-0900</a>
10	<a href="#">51065-1000</a>
11	<a href="#">51065-1100</a>

Circuits	Order No.
12	<a href="#">51065-1200</a>
13	<a href="#">51065-1300</a>
14	<a href="#">51065-1400</a>
15	<a href="#">51065-1500</a>



PRODUCT SPECIFICATION



LANGUAGE  
JAPANESE  
ENGLISH

【1. 適用範囲 SCOPE】

本仕様書は、 \_\_\_\_\_ 殿 に納入する

\_\_\_\_\_ 2. 0mmピッチ プリント基板用 コネクタ \_\_\_\_\_ について規定する。

This specification covers the 2.0mm PITCH WIRE TO BOARD CONNECTOR series.

【2. 製品名称及び型番 PRODUCT NAME AND PART NUMBER】

製品名称 Product Name	製品型番 Part Number
ターミナル Terminal (AWG #24~30)	50212-8*00
ターミナル Terminal (AWG #22~26)	50372-8*00
ハウジング Housing	51090-* *00
ウェハーアッセンブリ (ストレート) Wafer Assembly (ST.)	55460-* *10
ウェハーアッセンブリ (ストレート) エンボス梱包品 Embossed Tape Package for Wafer Assembly (ST.)	55460-* *90

\* : 図面参照(Refer to the drawing)

【3. 定格及び適用電線 RATINGS AND APPLICABLE WIRES】

項目 Items	規格 Standards	
最大許容電圧 Rated Voltage(MAX.)	125 V	
最大許容電流 及び適用電線 Rated Current (MAX.) and Applicable wires	AWG #22	2.5 A
	AWG #24	2.0 A
	AWG #26	1.5 A
	AWG #28	1.0 A
	AWG #30	0.5 A
使用温度範囲 Ambient Temperature Range	-40°C ~ +105°C*1	

[AC (実効値 rms) / DC]

被覆外径 : φ1.4 mm MAX.  
Insulation O.D.:

\*1 通電による温度上昇分も含む。  
Including terminal temperature rise.

REV.	A	A	A	A	A	A	A	A	A										
SHEET	1	2	3	4	5	6	7	8	9										
REVISE ON PC ONLY										TITLE: 2.0mm PITCH WIRE TO BOARD CONNECTOR 製品仕様書									
A 新規作成 RELEASED J2002-2334 '02/03/14 N.YANO										THIS DOCUMENT CONTAINS INFORMATION THAT IS PROPRIETARY TO MOLEX INC. AND SHOULD NOT BE USED WITHOUT WRITTEN PERMISSION.									
REV. DESCRIPTION										WRITTEN BY: N.YANO		CHECKED BY: S.AIHARA		APPROVED BY: M.SASAO		DATE: YR/MO/DAY 2002/03/14			
DESIGN CONTROL J										STATUS									
DOCUMENT NUMBER PS-51090-005										FILE NAME 51090005.doc				SHEET 1 OF 9					



# PRODUCT SPECIFICATION



LANGUAGE

JAPANESE  
ENGLISH

## 【4. 性能 PERFORMANCE】

### 4-1. 電気的性能 Electrical Performance

項番	項目 Items	条件 Test Conditions	規格 Requirements
4-1-1	接触抵抗 Contact Resistance	コネクタを嵌合させ、開放電圧 20mV 以下、短絡電流 10mAにて測定する。 (JIS C5402 5.4) mated connectors,measure by dry circuit, 20mV MAX., 10mA. (JIS C5402 5.4)	20 milli ohms MAX.
4-1-2	絶縁抵抗 Insulation Resistance	コネクタを嵌合させ、隣接するターミナル間及びターミナル、アース間に、DC 500V を印加し測定する。 (JIS C5402 5.2/MIL-STD-202 試験法 302) Connectors shall be mated and apply 500V DC between adjacent terminals or ground. (JIS C5402 5.2/MIL-STD-202 Method 302)	1000 Meg ohms MIN.
4-1-3	耐電圧 Dielectric Strength	コネクタを嵌合させ、隣接するターミナル間及びターミナル、アース間に、AC 500V (実効値) を1分間印加する。 (JIS C5402 5.1/MIL-STD-202 試験法 301) Connectors shall be mated and apply 500V AC (rms) for 1 minute between adjacent terminals or ground. (JIS C5402 5.1/MIL-STD-202 Method 301)	異状なきこと No breakdown
4-1-4	圧着部接触抵抗 Contact Resistance on Crimped Portion	ターミナルに適合電線を圧着し、開放電圧 20mV 以下、短絡電流 10mA にて測定する。 Crimped the applicable wire on to the terminal, measure by dry circuit, 20mV MAX., 10mA.	5 milli ohms MAX.

REVISE ON PC ONLY

**A**

SEE SHEET 1 OF 9

TITLE:

2.0mm PITCH WIRE TO BOARD CONNECTOR

製品仕様書

THIS DOCUMENT CONTAINS INFORMATION THAT IS PROPRIETARY TO MOLEX INC. AND SHOULD NOT BE USED WITHOUT WRITTEN PERMISSION.

REV.

DESCRIPTION

DOCUMENT NUMBER

**PS-51090-005**

FILE NAME

51090005.doc

SHEET

2 OF 9

EN-37-1(019)



# PRODUCT SPECIFICATION



LANGUAGE

JAPANESE  
ENGLISH

## 4-2. 機械的性能 Mechanical Performance

項番	項目 Items	条件 Test Conditions	規格 Requirements	
4-2-1	挿入力及び抜去力 Insertion and Withdrawal Force	毎分25±3mmの速さで、挿入、抜去を行う。 Insert and withdraw connectors at the speed rate of 25±3mm/minute.	第 6 項 参 照 See para 6.	
4-2-2	圧着部引張り強度 Crimping Pull Out Force	圧着されたターミナルを治具に固定し、電線を 軸方向に毎分25±3mmの速さで引張る。 (JIS C5402 6.8)  Fixed crimped terminal , apply axial pull out force on the wire at the speed rate of 25±3mm/minute. (JIS C5402 6.8)	AWG#22	39.2 N MIN. {4.0 kgf} MIN.
			AWG#24	29.4 N MIN. {3.0 kgf} MIN.
			AWG#26	19.6 N MIN. {2.0 kgf} MIN.
			AWG#28	9.8 N MIN. {1.0 kgf} MIN.
			AWG#30	4.9 N MIN. {0.5 kgf} MIN.
4-2-3	ターミナル挿入力 Terminal Insertion Force	圧着されたターミナルをハウジングに挿入する。 Insert the crimped terminal into the housing.	9.8 N { 1.0kgf } MAX.	
4-2-4	ターミナル保持力 Terminal / Housing Retention Force	圧着されたターミナルをハウジングに装着し、電線 を軸方向に毎分25±3mmの速さで引張る。 Apply axial pull out force at the speed rate of 25±3mm/minute on the terminal assembled in the housing.	9.8 N { 1.0kgf } MIN.	
4-2-5	ピン保持力 Pin Retention Force	毎分 25±3mm の速さでピンを軸方向に押す。 Apply axial push force at the speed rate of 25±3mm/minute.	9.8 N { 1.0kgf } MIN.	

## 4-3. その他 Environmental Performance and Others

項番	項目 Items	条件 Test Conditions	規格 Requirements	
4-3-1	繰返し挿抜 Repeated Insertion/ Withdrawal	1分間に 10回 以下の速さで挿入、 抜去を 30回繰返す。 When mated up to 30 cycles repeatedly by the rate of 10 cycles/minute.	接触抵抗 Contact Resistance	40 milli ohms MAX.
4-3-2	温度上昇 Temperature Rise	コネクタを嵌合させ、最大許容電流 を通電し、コネクタの温度上昇分を 測定する。(UL 498) Carrying rated crrent load. (UL 498)	温度上昇 Temperature Rise	30 °C MAX.

REVISE ON PC ONLY

**A**

SEE SHEET 1 OF 9

TITLE:

2.0mm PITCH WIRE TO BOARD CONNECTOR

製品仕様書

THIS DOCUMENT CONTAINS INFORMATION THAT IS PROPRIETARY TO  
MOLEX INC. AND SHOULD NOT BE USED WITHOUT WRITTEN PERMISSION.

REV.

DESCRIPTION

DOCUMENT NUMBER

**PS-51090-005**

FILE NAME

51090005.doc

SHEET

3 OF 9

EN-37-1(019)



PRODUCT SPECIFICATION



LANGUAGE

JAPANESE  
ENGLISH

項番	項目 Items	条件 Test Conditions	規格 Requirements	
4-3-3	耐振動性 Vibration	DC 1mA 通電状態にて、嵌合軸を含む互いに垂直な 3方向 に挿引割合 10~55~10 Hz/分 全振幅 1.5mm の振動を各 2時間 加える。 (MIL-STD-202 試験法 201) Amplitude : 1.5mm P-P Sweep time: 10-55-10 Hz in 1 minute Duration : 2 hours in each X.Y.Z. axes (MIL-STD-202 Method 201)	外観 Appearance	異常なきこと No Damage
			接触抵抗 Contact Resistance	40 milli ohms MAX.
			瞬断 Discontinuity	1 micro second MAX.
4-3-4	耐衝撃性 Mechanical Shock	DC 1mA 通電状態にて、嵌合軸を含む互いに垂直な 6方向に 490m/s <sup>2</sup> {50G} の衝撃を 各3回 加える。 (JIS C0041/MIL-STD-202 試験法 213) 490m/s <sup>2</sup> {50G},3 strokes in each X.Y.Z. axes. (JIS C0041/MIL-STD-202 Method 213)	外観 Appearance	異常なきこと No Damage
			接触抵抗 Contact Resistance	40 milli ohms MAX.
			瞬断 Discontinuity	1 micro second MAX.
4-3-5	耐熱性 Heat Resistance	コネクタを嵌合させ、105±2°C の雰囲気中に 96時間 放置後取り出し、1~2 時間 室温に放置する。 (JIS C0021/MIL-STD-202 試験法 108) 105±2°C,96 hours. (JIS C0021/MIL-STD-202 method 108)	外観 Appearance	異常なきこと No Damage
			接触抵抗 Contact Resistance	40 milli ohms MAX.
4-3-6	耐寒性 Cold Resistance	コネクタを嵌合させ、-40±3°C の雰囲気中に 96時間 放置後取り出し、1~2時間 室温に放置する。 (JIS C0020) -40±3°C,96 hours. (JIS C0020)	外観 Appearance	異常なきこと No Damage
			接触抵抗 Contact Resistance	40 milli ohms MAX.

REVISE ON PC ONLY

**A**

SEE SHEET 1 OF 9

TITLE:

2.0mm PITCH WIRE TO BOARD CONNECTOR

製品仕様書

THIS DOCUMENT CONTAINS INFORMATION THAT IS PROPRIETARY TO MOLEX INC. AND SHOULD NOT BE USED WITHOUT WRITTEN PERMISSION.

REV.

DESCRIPTION

DOCUMENT NUMBER

**PS-51090-005**

FILE NAME

51090005.doc

SHEET

4 OF 9

EN-37-1(019)



PRODUCT SPECIFICATION



LANGUAGE

JAPANESE  
ENGLISH

項番	項目 Items	条件 Test Conditions	規格 Requirements	
4-3-7	耐湿性 Humidity	コネクタを嵌合させ、60±2℃、 相対湿度 90~95%の雰囲気中に 96時間 放置後取り出し、1~2時間 室温に放置する。 (JIS C0022/MIL-STD-202 試験法 103) Temperature: 60±2℃ Relative Humidity: 90-95% Duration: 96 hours (JIS C0022/MIL-STD-202 Method 103)	外観 Appearance	異常なきこと No Damage
			接触抵抗 Contact Resistance	40 milli ohms MAX.
			耐電圧 Dielectric Strength	4-1-3項満足のこと Must meet 4-1-3
			絶縁抵抗 Insulation Resistance	100 Meg ohms MIN.
4-3-8	温度サイクル Temperature Cycling	コネクタを嵌合させ、-55℃ に 30分、+105℃ に 30分 これを 1 サイクル とし、5サイクル 繰返す。 但し、温度移行時間は 5分 以内と する。試験後 1~2時間 室温に 放置する。(JIS C0025) 5 cycle of: a) -55℃ 30 minutes b) +105℃ 30 minutes (JIS C0025)	外観 Appearance	異常なきこと No Damage
			接触抵抗 Contact Resistance	40 milli ohms MAX.
4-3-9	塩水噴霧 Salt Spray	コネクタを嵌合させ、35±2℃ にて 5±1% 重量比の塩水を 48±4時間 噴霧し、試験後常温で水洗いした 後、室温で乾燥させる。 (JIS C0023/MIL-STD-202 試験法 101) 48±4 hours exposure to a salt spray from the 5±1% solution at 35±2 °C (JIS C0023/MIL-STD-202 Method 101)	外観 Appearance	異常なきこと No Damage
			接触抵抗 Contact Resistance	40 milli ohms MAX.
4-3-10	亜硫酸ガス SO <sub>2</sub> gas	コネクタを嵌合させ、40±2℃ にて 50±5ppm の亜硫酸ガス中に 24時間 放置する。 24 hours exposure to 50±5 ppm. SO <sub>2</sub> gas at 40±2℃	外観 Appearance	異常なきこと No Damage
			接触抵抗 Contact Resistance	40 milli ohms MAX.

REVISE ON PC ONLY

**A**

SEE SHEET 1 OF 9

TITLE:

2.0mm PITCH WIRE TO BOARD CONNECTOR

製品仕様書

THIS DOCUMENT CONTAINS INFORMATION THAT IS PROPRIETARY TO MOLEX INC. AND SHOULD NOT BE USED WITHOUT WRITTEN PERMISSION.

REV.

DESCRIPTION

DOCUMENT NUMBER

**PS-51090-005**

FILE NAME

51090005.doc

SHEET

5 OF 9

EN-37-1(019)



PRODUCT SPECIFICATION



LANGUAGE

JAPANESE  
ENGLISH

項 番 Items	項 目 Items	条 件 Test Conditions	規 格 Requirements	
4-3-11	半田付け性 Solderability	ターミナルまたはピンをフラックスに浸し、本体の取付け基準面より1.2mm迄、230±5℃の半田に3±0.5秒浸す。 Soldering Time: 3±0.5秒 Solder Temperature: 230±5℃	濡れ性 Solder wetting	浸漬面積の75%以上 75% of immersed area must show no voids, pin holes
4-3-12	半田耐熱性 Resistance to Soldering Heat	(リフロ一時) 第7項参照 (When reflowing) Refer to paragraph 7 (手半田時) 端子先端より1.2mmの位置まで、350±5℃の半田ゴテにて3±0.5秒加熱後 Soldering Time: 3±0.5 sec. Solder Temperature: 350±5℃ 1.2 mm from terminal tip.	外 観 Appearance	端子ガタ、割れ等 異状なきこと No Damage

【5. 外観形状、寸法及び材質 PRODUCT SHAPE, DIMENSIONS AND MATERIALS】

図面参照 Refer to the drawing.

REVISE ON PC ONLY	A	SEE SHEET 1 OF 9	TITLE:	製品仕様書
			2.0mm PITCH WIRE TO BOARD CONNECTOR	
REV.	DESCRIPTION		THIS DOCUMENT CONTAINS INFORMATION THAT IS PROPRIETARY TO MOLEX INC. AND SHOULD NOT BE USED WITHOUT WRITTEN PERMISSION.	
DOCUMENT NUMBER PS-51090-005			FILE NAME 51090005.doc	SHEET 6 OF 9





【6. 挿入力及び抜去力 INSERTION / WITHDRAWAL FORCE】

極数 No. of CKT	単位 UNIT	挿入力 (最大値) Insertion Force (MAX.)			抜去力 (最小値) Withdrawal Force(MIN.)		
		初回 1st	6回目 6th	30回目 30th	初回 1st	6回目 6th	30回目 30th
3	N {kgf}	43.1 {4.40}	40.1 {4.10}	40.1 {4.10}	5.4 {0.55}	4.9 {0.50}	4.5 {0.45}
4	N {kgf}	50.9 {5.20}	47.0 {4.80}	47.0 {4.80}	6.9 {0.70}	5.9 {0.60}	4.9 {0.50}
5	N {kgf}	58.8 {6.00}	53.9 {5.50}	53.9 {5.50}	7.9 {0.80}	6.4 {0.65}	5.4 {0.55}
6	N {kgf}	64.6 {6.60}	58.8 {6.00}	58.8 {6.00}	8.9 {0.90}	6.9 {0.70}	5.9 {0.60}
7	N {kgf}	70.5 {7.20}	63.7 {6.50}	63.7 {6.50}	9.8 {1.00}	7.4 {0.75}	6.4 {0.65}
8	N {kgf}	76.4 {7.80}	68.6 {7.00}	68.6 {7.00}	10.8 {1.10}	7.9 {0.80}	6.9 {0.70}
10	N {kgf}	88.2 {9.00}	78.4 {8.00}	78.4 {8.00}	12.8 {1.30}	8.9 {0.90}	7.9 {0.80}
12	N {kgf}	99.9 {10.2}	88.2 {9.00}	88.2 {9.00}	14.7 {1.50}	9.8 {1.00}	8.9 {0.90}
13	N {kgf}	105.8 {10.8}	93.1 {9.50}	93.1 {9.50}	15.7 {1.60}	10.3 {1.05}	9.4 {0.95}
15	N {kgf}	117.6 {12.0}	102.9 {10.5}	102.9 {10.5}	17.7 {1.80}	11.3 {1.15}	10.3 {1.05}

REVISE ON PC ONLY		TITLE:	
<b>A</b>	SEE SHEET 1 OF 9	2.0mm PITCH WIRE TO BOARD CONNECTOR	
		製品仕様書	
REV.	DESCRIPTION	THIS DOCUMENT CONTAINS INFORMATION THAT IS PROPRIETARY TO MOLEX INC. AND SHOULD NOT BE USED WITHOUT WRITTEN PERMISSION.	
DOCUMENT NUMBER <b>PS-51090-005</b>		FILE NAME 51090005.doc	SHEET 7 OF 9



【 7. 赤外線リフロー条件 INFRARED REFLOW CONDITION】

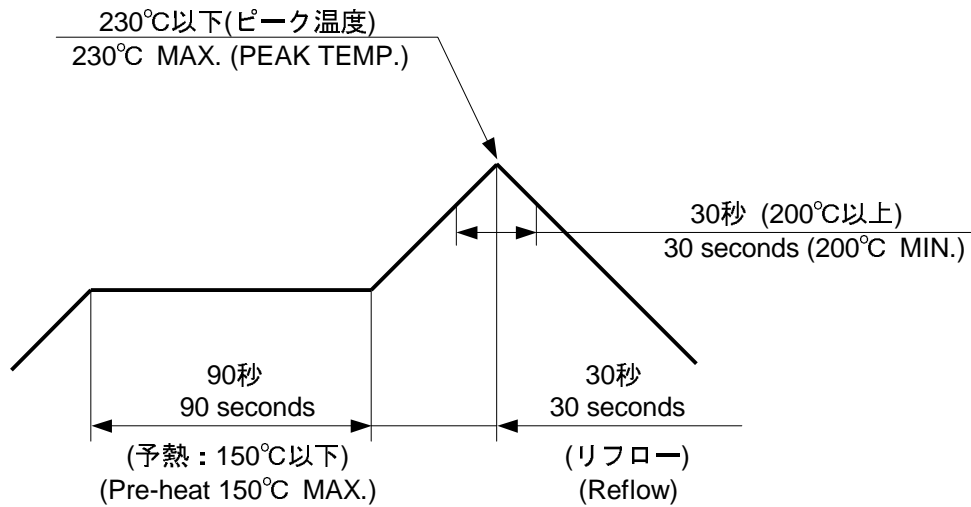

温度条件グラフ  
 (温度は基板パターン面)  
 TEMPERATURE CONDITION GRAPH  
 (TEMPERATURE ON BOARD PATTERN SIDE)

注記 ; 本リフロー条件に関しては、リフロー装置及び基板などにより条件が異なりますので、事前にリフロー評価の確認をお願い致します。

NOTE ; Please check the reflow soldering condition by your own devices beforehand. Because the condition changes by the soldering devices, P.C.Boards, and so on.

【 8. 使用上の注意事項 INSTRUCTION UPON USAGE】

1.コネクタの抜去は、右図の様に基板に対して垂直方向に全ケーブルを同時に引き上げる様に行ってください。

When the connector is withdraw , please withdraw all cables at the same time in the direction with vertical against the p.c board,as shown in the figure.

2.AWG# 2 8 及びAWG# 3 0 を御使用時には、端子の圧着引張り強度が低いので、電線を持つての抜去には、注意願います。

When the cables AWG#28 and AWG#30 are used, please take care about withdraw holding them. Because crimping pull out force is low.

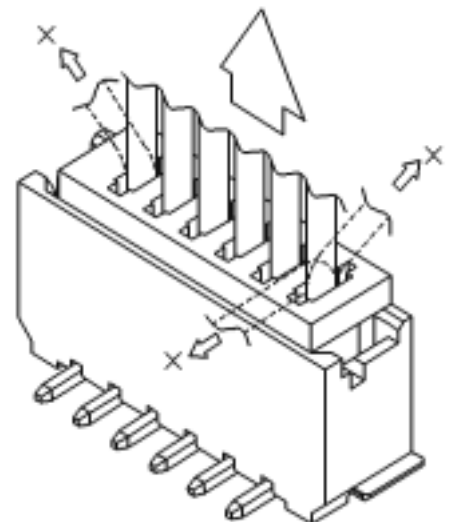

REVISE ON PC ONLY		TITLE:	
<b>A</b>	SEE SHEET 1 OF 9	2.0mm PITCH WIRE TO BOARD CONNECTOR	
	REV.	DESCRIPTION	製品仕様書
		THIS DOCUMENT CONTAINS INFORMATION THAT IS PROPRIETARY TO MOLEX INC. AND SHOULD NOT BE USED WITHOUT WRITTEN PERMISSION.	
DOCUMENT NUMBER <b>PS-51090-005</b>		FILE NAME 51090005.doc	SHEET 8 OF 9
EN-37-1(019)			



注記

- 適用ハウジング: 51065-\*\*\*00  
 APPLICABLE HOUSING 51089-\*\*\*05  
 51090-\*\*\*00
- 材質:  
 MATERIAL  
 リン青銅  
 PHOSPHOR BRONZE  
 錫メッキ  
 PRE-TINNED  
 $t=0.152$

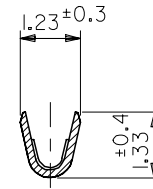
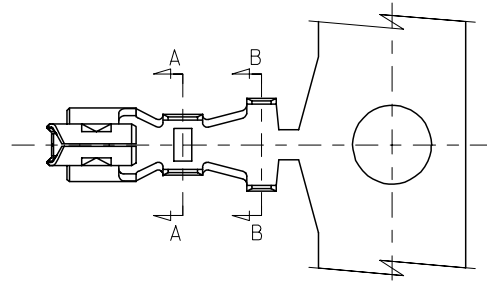

SECT. A-A

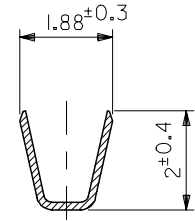

SECT. B-B

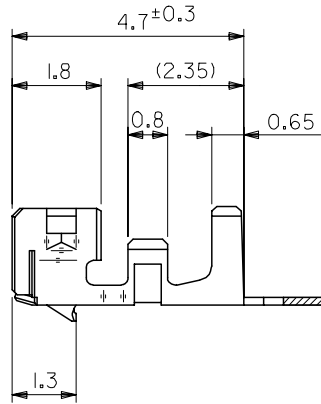
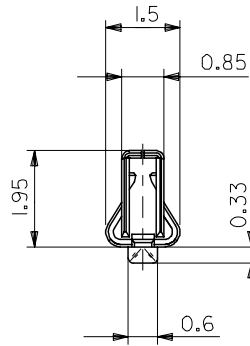

50212-8100	バラ状
50212-8000	連鎖状
MATERIAL NO.	端子形状

REVISED EC NO: J2006-1104 DRW: N. SUZUKI CHK: K. TOYODA APPR: N. KIKITA	GENERAL TOLERANCES (UNLESS SPECIFIED)		DIMENSION STYLE MM ONLY		SCALE 10:1	DESIGN UNITS METRIC	THIRD ANGLE PROJECTION	
	10 UNDER	±0.2	DRAWN BY	DATE	TITLE NEW 2.0 WIRE TO BOARD CONN. CRIMP RECEPTACLE			
	10 OVER 30 UNDER	±0.25	SAIHARA	89/09/21				
	30 OVER	±0.3	CHECKED BY	DATE				
		ANGULAR ±3 °	APPROVED BY	DATE	MOLEX INCORPORATED			
	DRAFT WHERE APPLICABLE MUST REMAIN WITHIN DIMENSIONS	MATERIAL NO.	DATE	SEE CHART		DOCUMENT NO. SD-50212-001	SHEET NO. 1 OF 1	

SIZE A3 THIS DRAWING CONTAINS INFORMATION THAT IS PROPRIETARY TO MOLEX INCORPORATED AND SHOULD NOT BE USED WITHOUT WRITTEN PERMISSION