

APPLICATION SPECIFICATION 2.0mm PITCH W/B CONN. DuraClik with Retainer

【0. SCOPE】

This specification covers handling of the 2.0mm pitch WIRE to BOARD connector (DuraClik™ with Retainer) series for _____.

【1. PRODUCT NAME AND PART NUMBER】

	Product Name		Part Number
Wire side	Receptacle Housing		505151 series
	Retainer		505152 series
	Receptacle terminal		5051538000
	Applicable wire (※)		0.3sq., AWG #22, #24
	Applicable crimp die model no.		5781423000(semi-auto) 5781423410(auto) 639034900 (semi-auto, for Fine Adjust™)
	Applicable crimping hand tool		638276400
PCB side	Wafer Assembly	R/A type	502352 series (EMBOSS package)
		S/T type	560020 series (EMBOSS package)

※ Please refer to CS/RCS-505153-*** for further details.

REVISION: A	ECM INFORMATION: EC No: 629338 DATE: 2019/12/24	TITLE: 2.0MM PITCH W/B CONN. DURA CLIK™ SERIES				SHEET No. 1 of 30
DOCUMENT NUMBER: AS-505151-002	DOC TYPE: PS	DOC PART: 001	CREATED / REVISED BY: MSATO08	CHECKED BY: HIIJIMA	APPROVED BY: TOSADA	

Structure

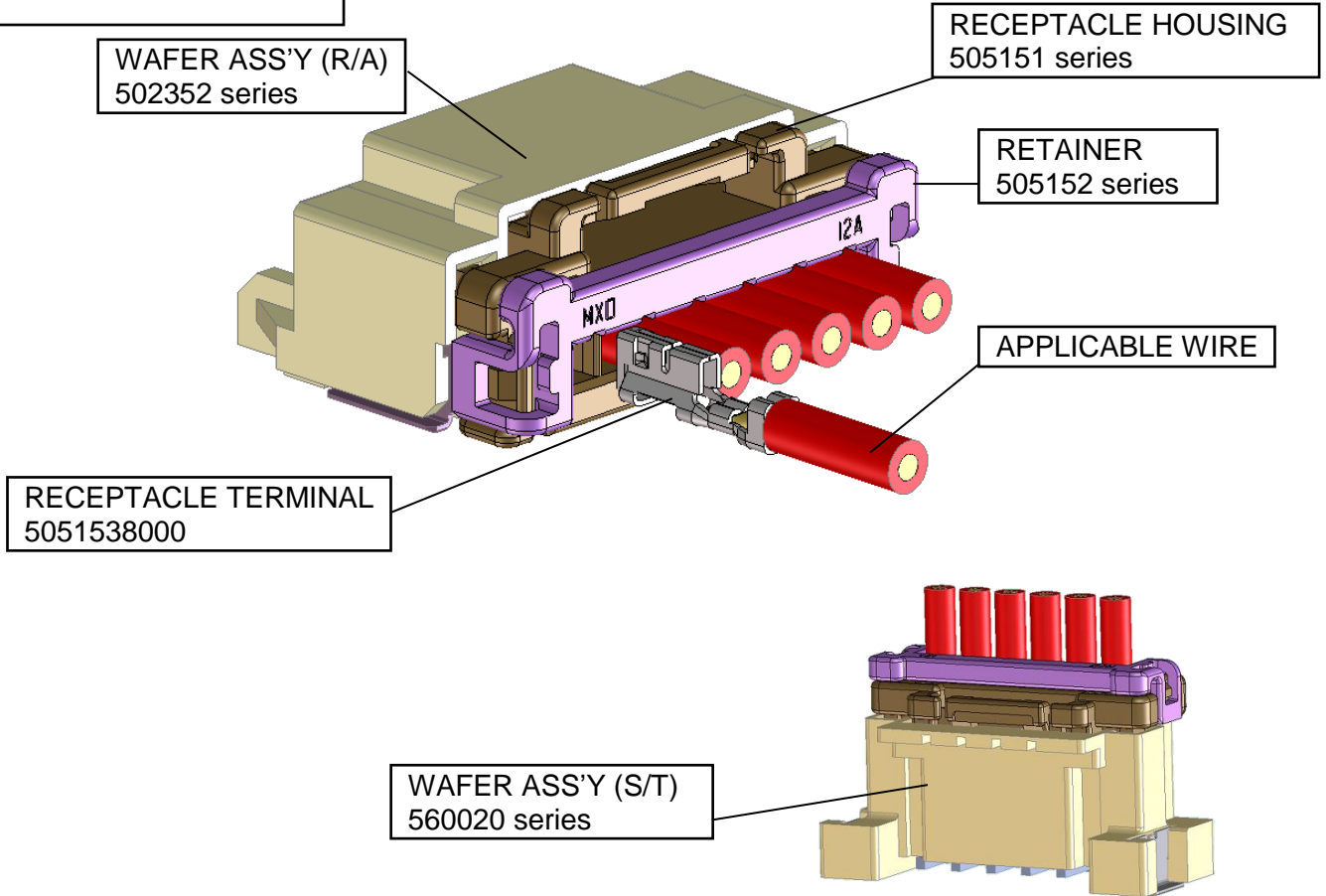

Fig.2 The structure of this product

— Before using —

- Be sure to read the following precautions before using connector.
- Keep this manual handy for later reference.
- The displays and illustrations shown in this manual are for illustrative purposes only and may differ from the actual product.
- The contents of this manual are subject to change without notice.
- If you find any mistake or there is anything that is not clear, please contact us.

REVISION: A	ECM INFORMATION: EC No: 629338 DATE: 2019/12/24	TITLE: 2.0MM PITCH W/B CONN. DURACLIC™ SERIES	SHEET No. 2 of 30
DOCUMENT NUMBER: AS-505151-002	DOC TYPE: PS	DOC PART: 001	CREATED / REVISED BY: MSATO08
		CHECKED BY: HIIJIMA	APPROVED BY: TOSADA

Contents

0. SCOPE	P-1
1. PRODUCT NAME AND PART NUMBER	P-1~2
2. Instructions	
2-1. Product exterior	P-4
2-2. Applicable wire and crimp tooling	P-4
2-3. About safekeeping before harness process and the surface mount process	P-4
2-4. Harness process and surface mount process instruction	P-4~5
2-5. About use in the machinery	P-6
2-6. About rating / performance standard	P-6
2-7. Use of the product	P-6
3. The name of each part and explanation	
3-1. Receptacle crimp terminal	P-7
3-2. Receptacle housing and harness	P-8
3-3. Retainer	P-9
3-4. Right Angle wafer assembly	P-10
3-5. Straight wafer assembly	P-10
4. Confirmation items of crimping wire	
4-1. The appearance before crimping	P-11
4-2. The appearance after crimping	P-11
4-3. Crimping failure	P-12~14
5. Wire bundling after crimping and package	P-14
6. Harness processing (crimping wire and retainer insertion method in receptacle housing)	
6-1. Insertion of crimping wire	P-16~18
6-2. Repair of crimping wire	P-19
6-3. Insertion of retainer	P-20~21
6-4. Repair of retainer	P-22
7. Banding of harness	P-23
8. Recommended packaging of cable harness and assemblies	P-24~25
9. Instruction when mating with HDR connector	
9-1. Recommended mating method	P-26~27
9-2. Recommended withdrawal method	P-27
9-3. Wiring after mating	P-28~29

REVISION: A	ECM INFORMATION: EC No: 629338 DATE: 2019/12/24	TITLE: 2.0MM PITCH W/B CONN. DURACLIK™ SERIES	SHEET No. 3 of 30
DOCUMENT NUMBER: AS-505151-002	DOC TYPE: PS	DOC PART: 001	CREATED / REVISED BY: MSATO08
	CHECKED BY: HIJIMA	APPROVED BY: TOSADA	

[2. Instruction]

2-1. Product exterior

1. There is no influence on the product performance though the black spots or bubbles etc. might be confirmed on the plastic part of this product and the color might be different (discoloration by secular distortion etc.).
2. Slide marks may sometimes appear in plating part of the product, but there is no impact on the function of this product.
3. Resin and terminal plating may have some changes in color after reflow but there is no negative impact on the function of this product.
4. Connectors may be damaged by applying force in the machines. Please confirm before use.

2-2. Applicable wire and crimp tooling

1. Guarantee is void when product is used with wire out of application range specified in the product specifications.
2. Guarantee is void when product is used with tooling not specified by Molex.
3. The recommended electric wire is tin plating. Please confirm separately about the use of other electric wires.

2-3. About safekeeping before harness process and the surface mount process

1. Please keep the products with the delivery being in a state. Also, please keep it under normal temperature and humidity avoiding direct sunlight.
2. Please do not allow external force from being applied during the storage.
3. During handling, avoid shock or dropping products as it may cause damage.
4. First-in, first-out of the stock is recommended.
5. Keep product in original packaging before using.
6. This product should be inspected its appearance and solder performance before using after expiration date.

2-4. Harness process and surface mount process instruction

1. Please confirm if the products and crimp machine, crimp condition, an applicable wire are equal to product drawing, crimp specifications before use.
2. Beware of unintended damage caused by dust, debris, or foreign objects before using this product. It may result in un-satisfaction of the insertion performance to the housing and electric performance.
3. Please do not touch the terminal by bare hand.
4. When a terminal is twisted or tangled before or after crimping, please do not pull it by force. The terminal may become damaged.
5. Do not apply force to the product during work in process or in finishing goods. Product may be damaged and may not function properly as a connector.

REVISION: A	ECM INFORMATION: EC No: 629338 DATE: 2019/12/24	TITLE: 2.0MM PITCH W/B CONN. DURACLIK™ SERIES				SHEET No. 4 of 30
DOCUMENT NUMBER: AS-505151-002		DOC TYPE: PS	DOC PART: 001	CREATED / REVISED BY: MSATO08	CHECKED BY: HIIJIMA	APPROVED BY: TOSADA

6. Please do not expose a product and a harness half-finished goods to the following condition.

- Dust
- Corrosive material
- Corrosive gas
- High temperature and high humidity
- Direct sunlight

The above-mentioned conditions may cause poor contact and the corrosion of the terminal and the insulation performance deterioration of the housing. Please keep in boxes.

7. Please do not add loads to connector and harness half-finished goods during production, packaging, transportation, or storage. It may cause damage and result in poor performance.
8. When pulling the electric wire of harness half-finished goods, contact defect may be caused by adding load to contacts, crimp parts and lock parts. When performing the guidance wiring of the electric wire, do not apply excessive forces that the connector can't withstand.
9. Do not damage receptacle crimp housing and a crimp terminal intentionally. Product performance can be affected by this condition.
10. Please use the product within the day the package is opened. Moisture absorption or drying may cause the deterioration of materials by neighboring atmospheres. When you cannot use it up, please seal the bag again and keep it in a box.
11. Please be careful not to be injured by the edges part such as metal parts when handling a connector.
12. To avoid injury, please be careful when handling the paper between terminals and metal carrier on reels.
13. Our evaluation is with the use of standard rigid PCB. When the product is used on flexible printed circuits (FPC) please evaluate in advance.
14. Please solder all the terminal departments and the nail part. Non-soldered part may cause defect.
15. In the case of changing our recommended board pattern size or design, please consult us in advance because such changes may cause defects.
16. Please do not apply to load the connector. For example, carrying the PCB when connector is mated may cause damage.
17. Please do not stack PCB after connector has soldered to PCB.
18. Please follow the conditions of specifications, when the connecting connector with a soldering iron. For conditions exceeding specifications, the connector may be damaged.
19. When using a solder iron, please do not use excessive solder and flux. It may cause poor contact performance by solder wicking and flux wicking.
20. There may be changes in color of the resin part and twisting in the terminal plating parts depending on the flow conditions, but it does not degrade product performance.
21. Do not coil electric wires around the housing or the gap of the housing lock during harness processing and packaging of harness product. In addition, please do not pull an electric wire by force when an electric wire has coiled itself around the housing and the gap of the housing lock. If wire becomes tangled, it may cause terminal damage. Please do not apply load to housing lock when removing wires.

REVISION: A	ECM INFORMATION: EC No: 629338 DATE: 2019/12/24	TITLE: 2.0MM PITCH W/B CONN. DURACLIC™ SERIES				SHEET No. 5 of 30
DOCUMENT NUMBER: AS-505151-002		DOC TYPE: PS	DOC PART: 001	CREATED / REVISED BY: MSATO08	CHECKED BY: HIIJIMA	APPROVED BY: TOSADA
TEMPLATE FILENAME: APPLICATION_SPEC[SIZE_A4](V.3).DOC						

2-5. About use in the machinery

1. Vibration of an electric wire or printed circuit board due to machinery vibration or rotation must be avoided to prevent damage to connector at contact area. Contact failure due to abrasion may be caused. Therefore, please fix electric wires and printed circuit boards in the machinery and take measures to hold resonances.
2. Do not fix printed circuit boards only by using connectors. They must be fixed or supported by other means.
3. Please do not touch terminals and fitting nails before and after mounting on the circuit board.
4. Please insert and withdraw connector along fixed axis. The diagonal insertion and withdrawal cause damage to the connector.
5. After mating, do not intentionally apply force to span or rotate a connector. Such force may cause damage to connector or solder cracking.
6. If an electric wire is pulled after mating a connector, it may damage contact or crimping areas or the lock area and result in contact failure. When performing the guidance wiring of the electric wire. Please keep the wire loose to avoid applying excessive force to connector.
7. When withdrawing the connector, please hold wire lightly and remove the lock securely using the entire finger.
8. Plastic lances may be damaged after removing crimp terminals. Therefore, please use a new crimp housing when repairing a connector.

2-6. About rating / performance standard

1. Please use the product within the rating / the standard of product specifications (PS-505151-001/RPS-505151-***).
2. This product is not designed for usage in “hot-swap” applications where power is on.
3. Please confirm that machinery design standards are satisfied before using the connector.
4. In order to avoid short circuits, please do not allow connectors to contact with metal objects.
5. Please avoid using current higher than the rated current.

2-7. Use of the product

1. This product is not designed and produced for the machine to be used under the condition involving human lives or for the use of system. If you use this product for special use such as medical, aerospace and nuclear power etc., please confirm us before using.
2. Please avoid using the product outdoors or under similar environment.

<u>REVISION:</u> A	<u>ECM INFORMATION:</u> EC No: 629338 DATE: 2019/12/24	<u>TITLE:</u> 2.0MM PITCH W/B CONN. DURACLIC™ SERIES				<u>SHEET No.</u> 6 of 30
<u>DOCUMENT NUMBER:</u> AS-505151-002		<u>DOC TYPE:</u> PS	<u>DOC PART:</u> 001	<u>CREATED / REVISED BY:</u> MSATO08	<u>CHECKED BY:</u> HIIJIMA	<u>APPROVED BY:</u> TOSADA

【3. The name of each part and explanation】

3-1. Receptacle crimp terminal : 505153 series

It shows Reel state

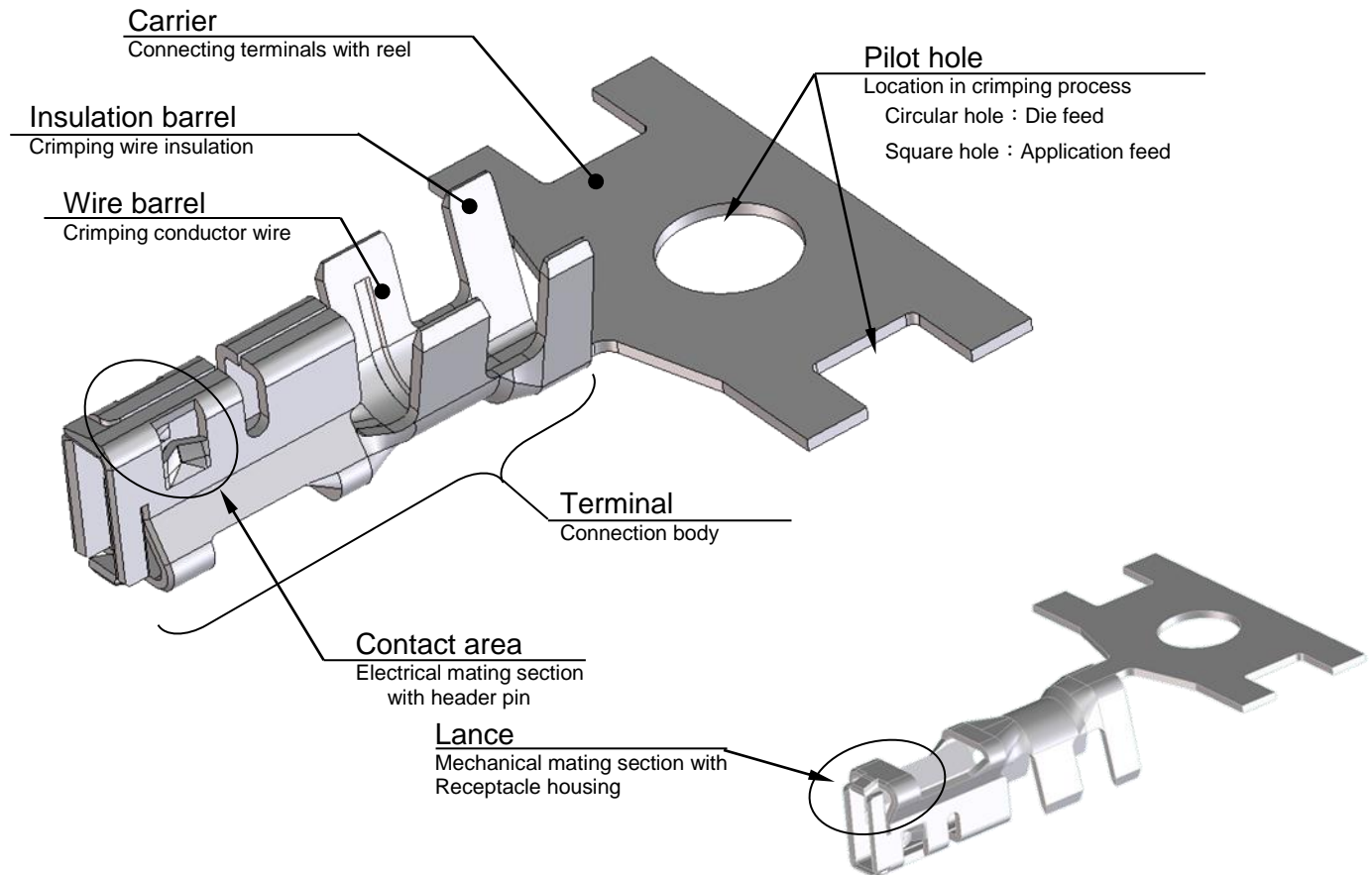

Fig.3-1 The name of Receptacle terminal

※ Please refer to sales drawing (SD/RSD-505153-**) for product form and its dimensions.

—APPLICABLE WIRE AND APPLICABLE CRIMP DIE MODEL—

Part Number	Wire size	Conductor spec.
5051538000	0.3sq, AWG#22~24	Tinned copper wire
Applicable crimp die model No.		5781423000(for semi-auto machine) 5781423410(for automatic machine)
Applicable crimping hand tool No.		639034900 (for Fine Adjust™) 638276400

REVISION: A	ECM INFORMATION: EC No: 629338 DATE: 2019/12/24	TITLE: 2.0MM PITCH W/B CONN. DURA CLIK™ SERIES				SHEET No. 7 of 30
DOCUMENT NUMBER: AS-505151-002	DOC TYPE: PS	DOC PART: 001	CREATED / REVISED BY: MSATO08	CHECKED BY: HIIJIMA	APPROVED BY: TOSADA	

3-2. Receptacle housing and harness : 505151 series

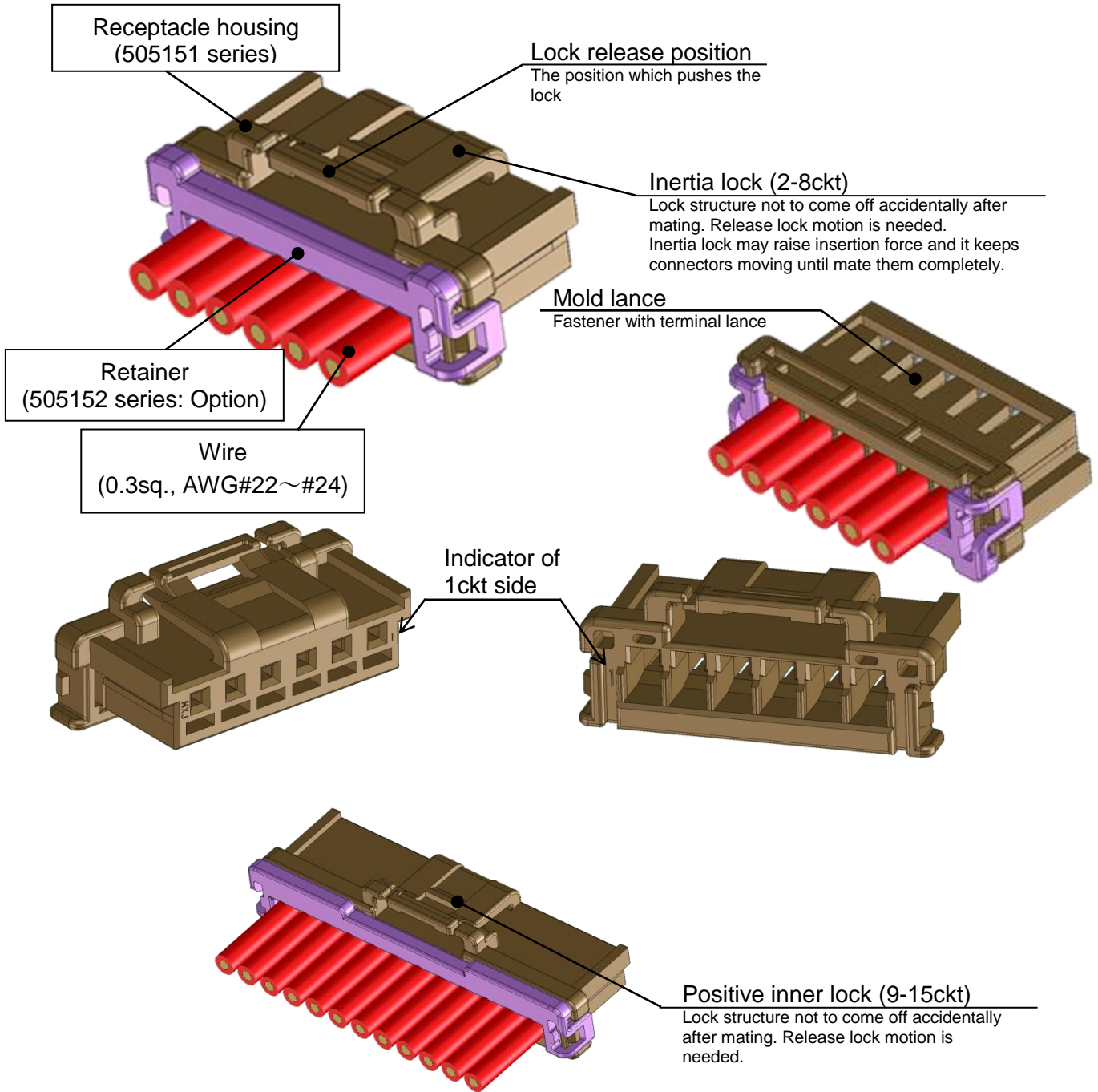

Fig.3-2 The name of harness

※ Please refer to sales drawing (SD/RSD-505151-*** for product form and its dimensions.

REVISION: A	ECM INFORMATION: EC No: 629338 DATE: 2019/12/24	TITLE: 2.0MM PITCH W/B CONN. DURACLIC™ SERIES	SHEET No. 8 of 30		
DOCUMENT NUMBER: AS-505151-002	DOC TYPE: PS	DOC PART: 001	CREATED / REVISED BY: MSATO08	CHECKED BY: HIIJIMA	APPROVED BY: TOSADA

3-3. Retainer : 505152 series (Option)

Lock

Guidance when insert to Receptacle housing, and hold its position after mating.

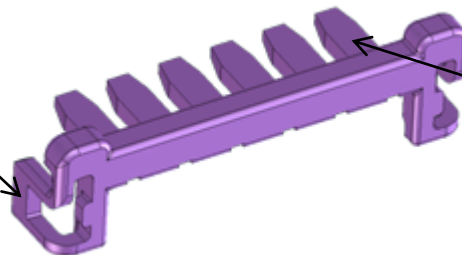

Terminal pusher

The comb-like region for push each terminal completely

Fig.3-3 The name of Retainer

※ Please refer to sales drawing (SD/RSD-505152-***) for product form and its dimensions.

REVISION: A	ECM INFORMATION: EC No: 629338 DATE: 2019/12/24	TITLE: 2.0MM PITCH W/B CONN. DURACLIK™ SERIES	SHEET No. 9 of 30		
DOCUMENT NUMBER: AS-505151-002	DOC TYPE: PS	DOC PART: 001	CREATED / REVISED BY: MSATO08	CHECKED BY: HIIJIMA	APPROVED BY: TOSADA
TEMPLATE FILENAME: APPLICATION_SPEC\SIZE_A4\{V.3}.DOC					

3-4. Right Angle wafer assembly : 502352 series

Lock for mating

Locking position with Receptacle housing

Header pin

Electrical mating part with Receptacle terminal

Housing

Nail

For soldering part

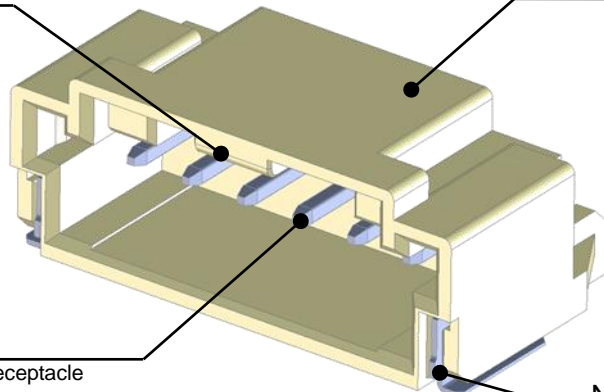

Fig.3-4 The name of wafer ass'y (Right Angle)

※ Please refer to sales drawing (SD/RSD-502352-***) for product form and its dimensions.

3-5. Straight wafer assembly : 560020 series

Lock for mating

Locking position with Receptacle housing

Housing

Header pin

Electrical mating part with Receptacle terminal

Nail

For soldering part

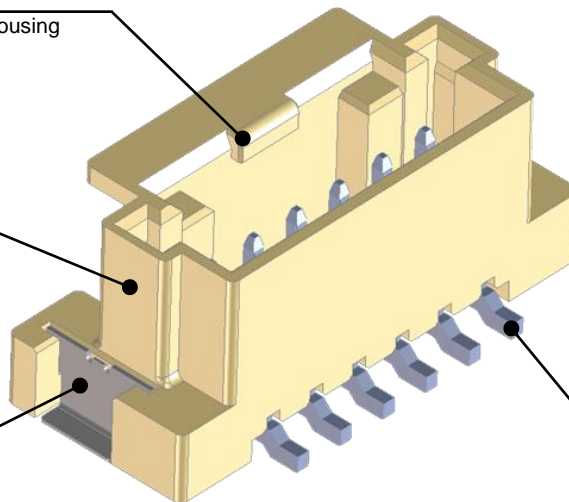

Fig.3-5 The name of wafer ass'y (Straight)

※ Please refer to sales drawing (SD/RSD-560020-***) for product form and its dimensions.

REVISION: A	ECM INFORMATION: EC No: 629338 DATE: 2019/12/24	TITLE: 2.0MM PITCH W/B CONN. DURACLIC™ SERIES	SHEET No. 10 of 30		
DOCUMENT NUMBER: AS-505151-002	DOC TYPE: PS	DOC PART: 001	CREATED / REVISED BY: MSATO08	CHECKED BY: HIIJIMA	APPROVED BY: TOSADA

【4. Confirmation items of crimping wire】

4-1. The appearance before crimping

When using the loose terminals products before crimping, please make sure that there is no deformation of the crimp Terminal. If you find that the terminals are tangled, please do not remove them forcibly. Please refer to sales drawing (SD/RSD-505153-***) for product form and its dimensions.

4-2. The appearance after crimping

Confirmation items and crimping failure after crimping are shown as follows. Please refer to CS/RCS-505153-*** for specified crimp height, pull testing, and applicable wire specifications.

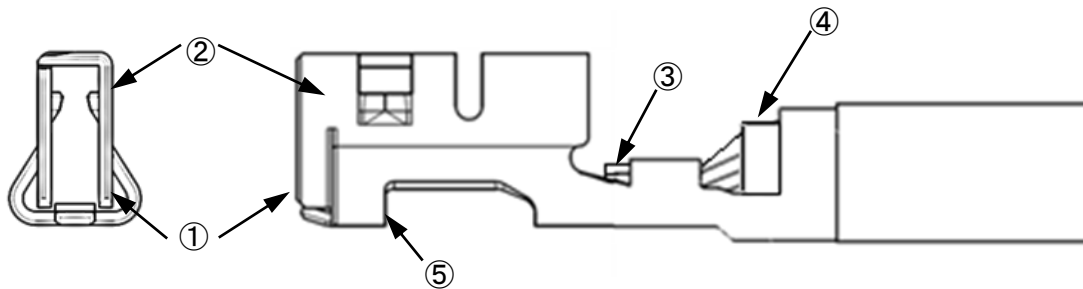

Fig.4-1

- ① No visible damage on terminal.
- ② No visible damage or deformation on spring contact area.
- ③ All wire strands are in conductor barrel.
- ④ The insulator part of the electric wire is located in the intermediate position of wire barrel and insulation barrel.
- ⑤ No damage on terminal lance.
- ⑥ No damage on appearance. (Dirt / foreign objects)

REVISION: A	ECM INFORMATION: EC No: 629338 DATE: 2019/12/24	TITLE: 2.0MM PITCH W/B CONN. DURACLIC™ SERIES	SHEET No. 11 of 30
DOCUMENT NUMBER: AS-505151-002	DOC TYPE: PS	DOC PART: 001	CREATED / REVISED BY: MSATO08
		CHECKED BY: HIIJIMA	APPROVED BY: TOSADA

4-3. Crimping failure

Please be careful of the crimping failure as shown below. It may affect the insertion to housing and affect a product function.

① Bend up

It may deteriorate insertion to housing and terminal retention force or cause contact failure.

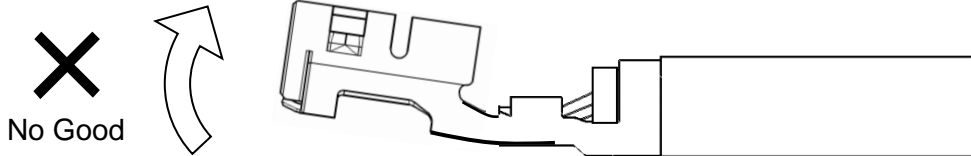

Fig.4-2

② Bend Down

It may deteriorate insertion to housing and terminal retention force or cause contact failure.

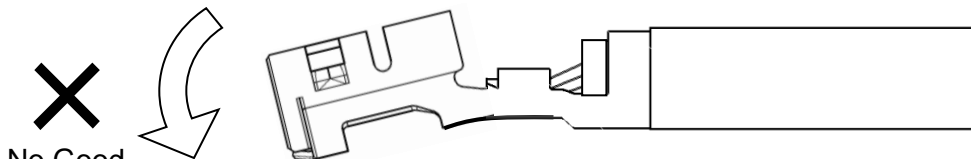

Fig.4-3

③ Twist

It may deteriorate insertion to housing and terminal retention force or cause contact failure.

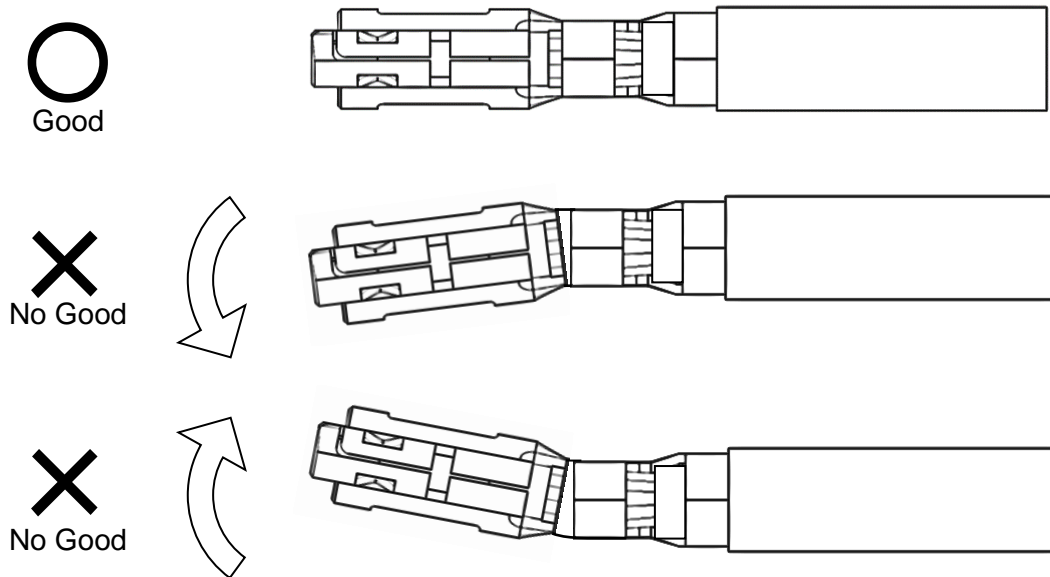

Fig.4-4

REVISION: A	ECM INFORMATION: EC No: 629338 DATE: 2019/12/24	TITLE: 2.0MM PITCH W/B CONN. DURACLIC™ SERIES	SHEET No. 12 of 30		
DOCUMENT NUMBER: AS-505151-002	DOC TYPE: PS	DOC PART: 001	CREATED / REVISED BY: MSATO08	CHECKED BY: HIIJIMA	APPROVED BY: TOSADA

④ Rolling

It may deteriorate insertion to housing and terminal retention force or cause contact failure.

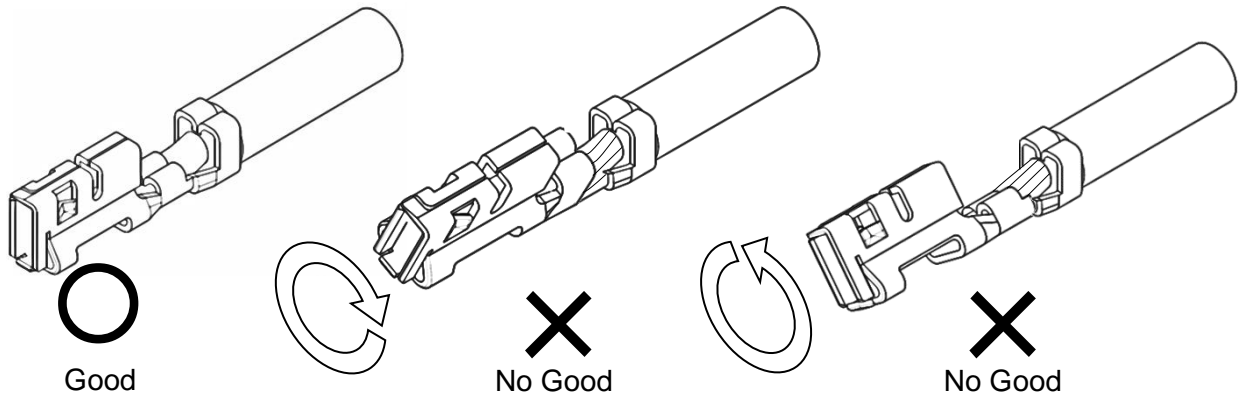

Fig.4-5

⑤ Crush and deformation of contact area and contact box

It may deteriorate insertion to housing and terminal retention force or cause contact failure.

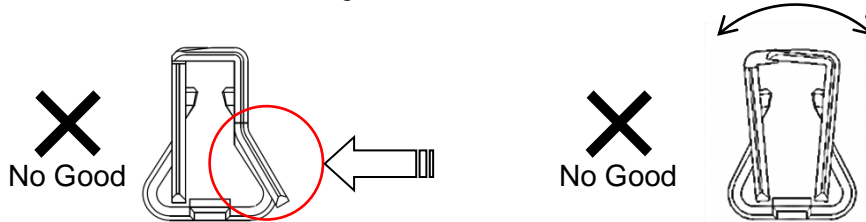

Fig.4-6

⑥ Wire strands are not inside the conductor barrel

It may deteriorate insertion to housing and terminal retention force or cause contact failure.

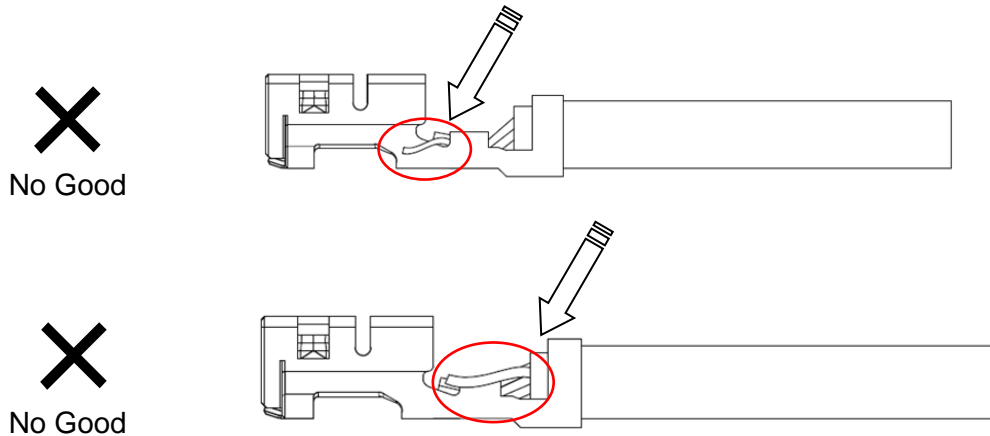

Fig.4-7

REVISION: A	ECM INFORMATION: EC No: 629338 DATE: 2019/12/24	TITLE: 2.0MM PITCH W/B CONN. DURA CLIK™ SERIES	SHEET No. 13 of 30		
DOCUMENT NUMBER: AS-505151-002	DOC TYPE: PS	DOC PART: 001	CREATED / REVISED BY: MSATO08	CHECKED BY: HIIJIMA	APPROVED BY: TOSADA

⑦ Crimping position: Too front

It may cause breaking of wire, deterioration of wire crimping strength and disconnection by crimping insulator.

X
No Good

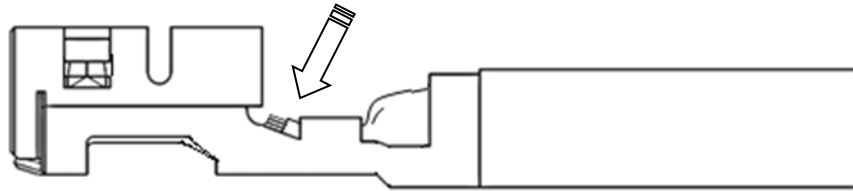

Fig.4-8

⑧ Crimping position: Too back

It may cause deterioration of wire crimping strength and disconnection by not having enough crimping margin

X
No Good

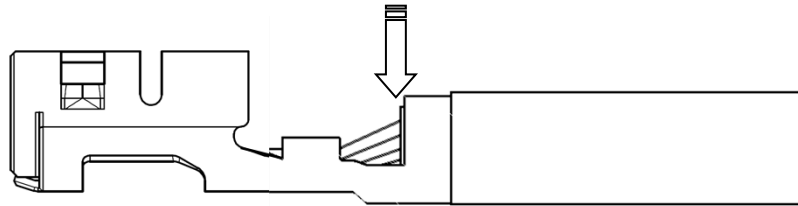

Fig.4-9

As wire Insulation is not crimped completely, wire insulation falls off easily when wire is pulled.

X
No Good

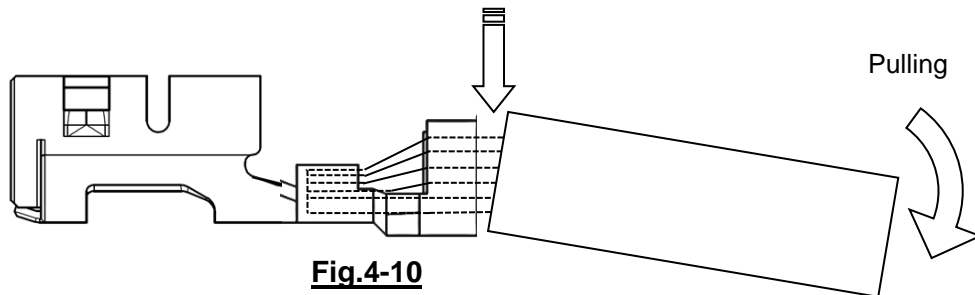

Fig.4-10

⑨ Deformation of terminal lance

Locking of the terminal becomes insufficient and causes lowering of the terminal retention force.

X
No Good

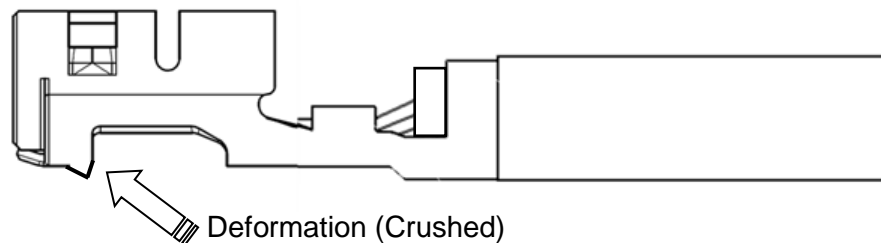

Fig.4-11

REVISION: A	ECM INFORMATION: EC No: 629338 DATE: 2019/12/24	TITLE: 2.0MM PITCH W/B CONN. DURACLIK™ SERIES	SHEET No. 14 of 30		
DOCUMENT NUMBER: AS-505151-002	DOC TYPE: PS	DOC PART: 001	CREATED / REVISED BY: MSATO08	CHECKED BY: HIIJIMA	APPROVED BY: TOSADA

【5. Wire bundling after crimping and package】

Please check for damaged terminal and wire insulation, when bundling wires. (We recommend to tie at about 30mm from crimp-end when these wires are bundled up by rubber band. (Fig.5-1))

Please check for the quantity per packing-box.

Do not over pack crimped wires in a box as there is risk of damaging terminals.

Instruction

- ※When bundling wires, please be careful not to apply excessive force to terminals. Do not fling to workbench in order to be line up the wire end.
- ※When packing bundled harnesses after processing in package box, in order for force not to be applied to connector for a long period of time by piling up, please put product alternately (cross shape) in a fitting box. (Fig.5-2)
- ※Please lay buffer material on the bottom and top of the package box. In order to avoid applying force to connector for a long period of time by stacking the wires, please lay buffer material. (Fig.5-2)

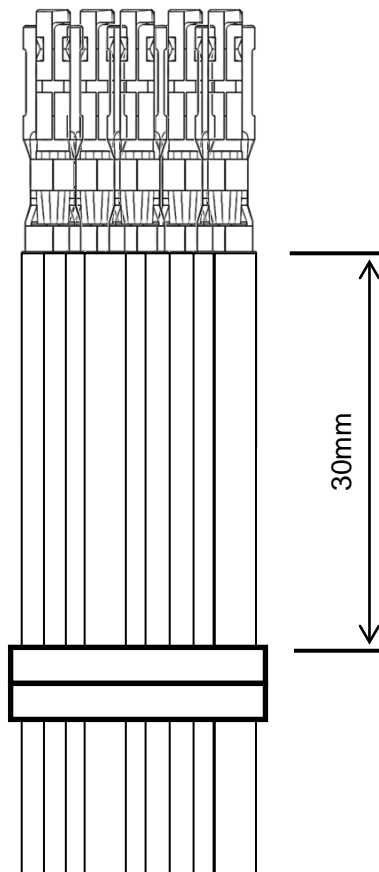

Fig. 5-1

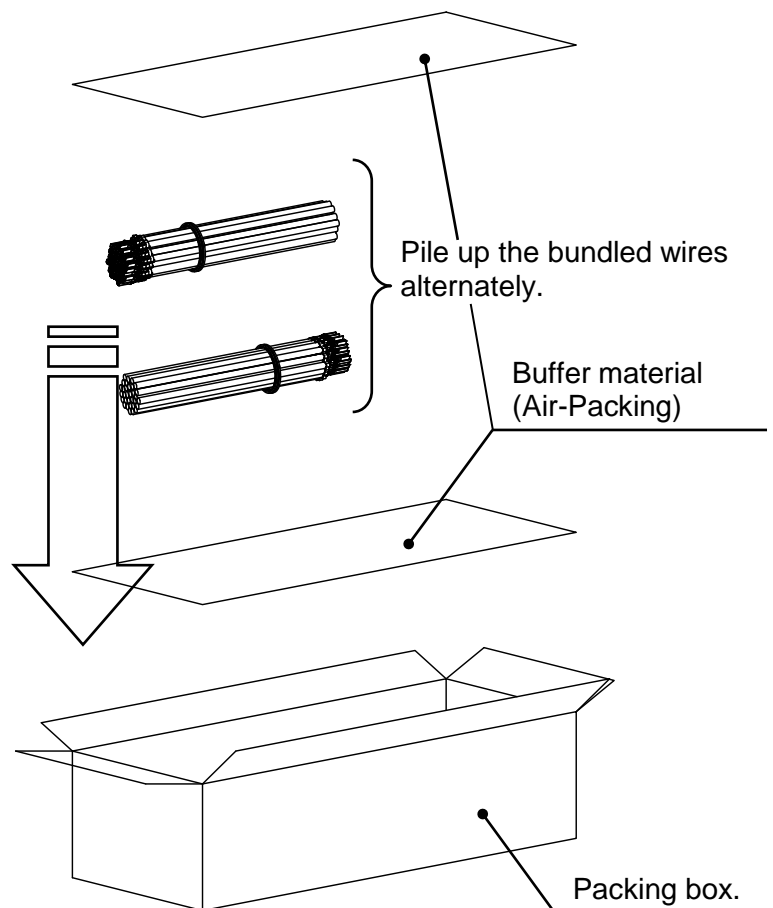

Fig. 5-2

REVISION: A	ECM INFORMATION: EC No: 629338 DATE: 2019/12/24	TITLE: 2.0MM PITCH W/B CONN. DURA CLIK™ SERIES	SHEET No. 15 of 30		
DOCUMENT NUMBER: AS-505151-002	DOC TYPE: PS	DOC PART: 001	CREATED / REVISED BY: MSATO08	CHECKED BY: HIIJIMA	APPROVED BY: TOSADA

【6. Harness processing (crimping wire and retainer insertion method in Receptacle housing)】

Insertion procedure and instructions (※) of the crimping wire are shown as follows:

6-1. Insertion of crimping wire

- ① Hold receptacle housing by pinching right and left side. Hold the cable at about 10mm away from the crimp-end with fingers lightly.

Instruction

※If you hold the wire at a position distant from terminal, wires will be easily bent and it may be difficult to insert.

※Distance value depends on wire gauge, UL, etc. Please confirm with the wire that you chose before using.

- ② Hold the terminal lance part toward center of receptacle housing and insert terminal slowly and straightly till the tip of terminal touches housing (with force of around 1.5~4N). **(Fig.6-1)**

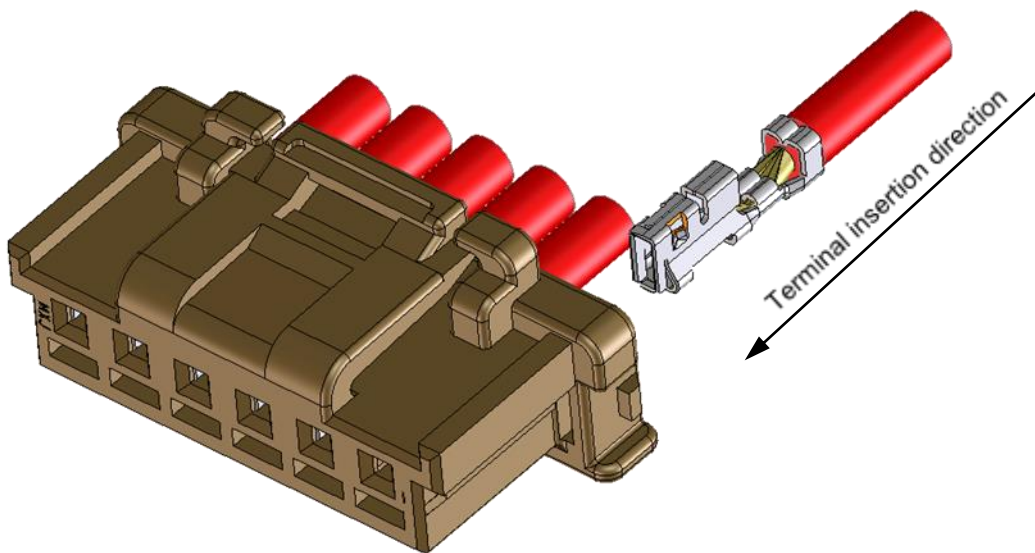
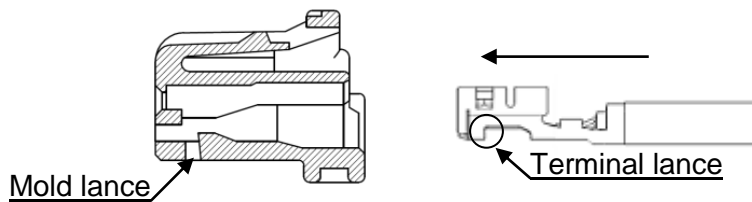

Fig. 6-1

REVISION: A	ECM INFORMATION: EC No: 629338 DATE: 2019/12/24	TITLE: 2.0MM PITCH W/B CONN. DURACLIK™ SERIES	SHEET No. 16 of 30		
DOCUMENT NUMBER: AS-505151-002	DOC TYPE: PS	DOC PART: 001	CREATED / REVISED BY: MSATO08	CHECKED BY: HIIJIMA	APPROVED BY: TOSADA

Instruction

- ※If crimping height and width are too large, there is a problem for the terminal insertion. Please follow the instructed crimping height. (Please refer to crimping specifications CS/RCS-505153-***)
- ※Please use care with the direction of terminal when inserting to receptacle housing. **(Fig.6-2,6-3)** Please be careful that the terminal is not upside down, not having an angle, or not rotated against receptacle housing. These may cause terminal deformation or damage to receptacle housing.
- ※If you feel unusual such as hooking during the insertion, please do not continue by force. After confirming there is no damage of terminal or receptacle housing, it can be inserted again. If the damage is found, do not use the terminal and receptacle housing.



○ **Fig.6-2 Right insertion direction**

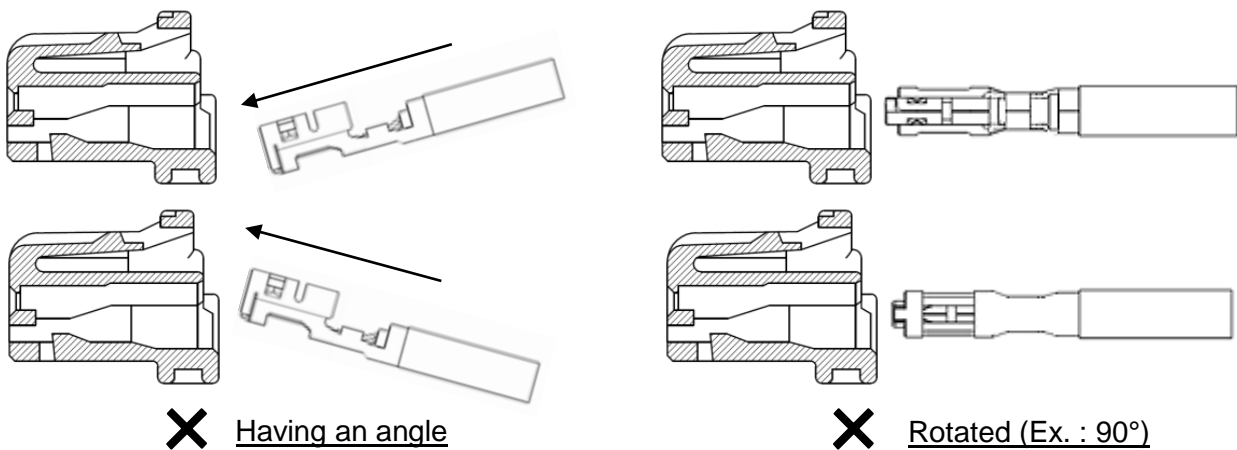
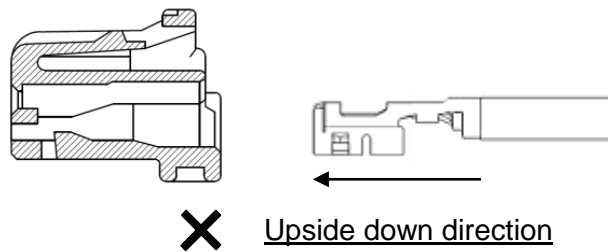

Fig.6-3 Inappropriate insertion direction

REVISION: A	ECM INFORMATION: EC No: 629338 DATE: 2019/12/24	TITLE: 2.0MM PITCH W/B CONN. DURA CLIK™ SERIES	SHEET No. 17 of 30		
DOCUMENT NUMBER: AS-505151-002	DOC TYPE: PS	DOC PART: 001	CREATED / REVISED BY: MSATO08	CHECKED BY: HIIJIMA	APPROVED BY: TOSADA

- ③ After inserting the terminal, please confirm if terminals are not pulled out from receptacle housing by pulling wires lightly (with about 100g force). Confirmation by excessive tension might break connector.
- ④ After inserting all terminals, please confirm the position of terminal lance part by looking through window of receptacle mold lance. If they are inserted correctly, terminal lance is at the position where terminal lance rode up mold lance properly and you can confirm clearance by shaking them axially lightly. (Fig.6-4/6-5/6-6)

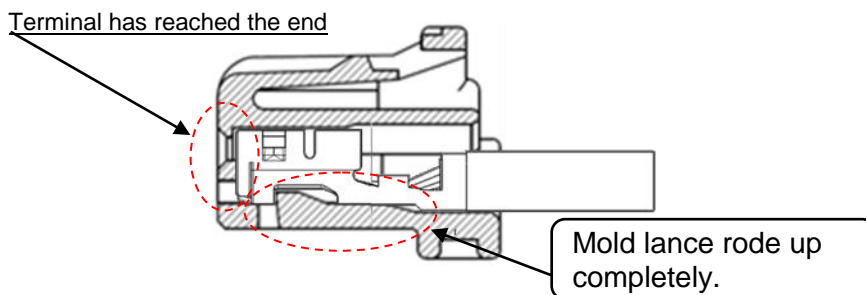

Fig.6-4 The case of correct insertion

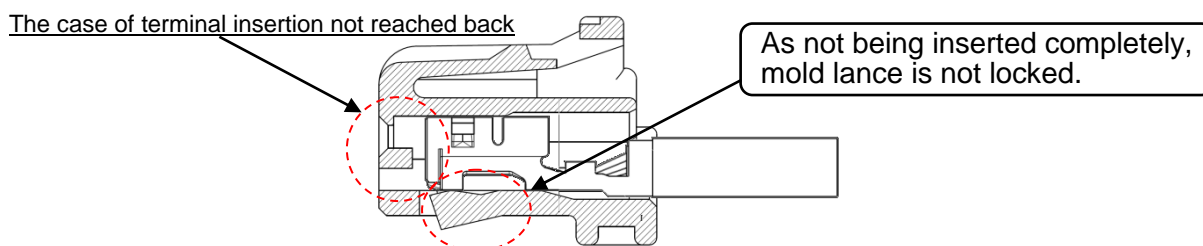

Fig.6-5 The case of incomplete insertion

Instruction

- ※If terminal is inserted incompletely, terminal lance is not locked with mold lance and terminal is not retained.
 - ※In the area of incomplete insertion (see Fig.6-5), terminal lance is transformed the most. (Therefore, mold lance of harness with such condition is transformed and not go back to correct position, resulting in degradation of retention force even though it is re-inserted.) In this case, please be sure to change with a new terminal.
- ⑤ When checking harness after processing, please avoid bending wire excessively or with tension. That might cause contact failure because force was added to terminal crimping part or receptacle housing lance part.
 - ⑥ When having a conduction check, do not attach anything besides applicable mating connector. That might cause contact failure because of transformation of terminal etc.

REVISION: A	ECM INFORMATION: EC No: 629338 DATE: 2019/12/24	TITLE: 2.0MM PITCH W/B CONN. DURACLIC™ SERIES	SHEET No. 18 of 30		
DOCUMENT NUMBER: AS-505151-002	DOC TYPE: PS	DOC PART: 001	CREATED / REVISED BY: MSATO08	CHECKED BY: HIJIMA	APPROVED BY: TOSADA

6-2. Repair of crimp terminal

When you withdraw the crimp terminal inserted once, please withdraw it with raising mold lance using something sharp like needle.

However, mold lance is transformed by being raised. As strength of the transformed lance decreases extremely, the terminal might come off easily from housing even if you insert it again.

Therefore, please be sure to change the receptacle housing to a new one when you repair crimp terminal.

Instruction

- ※Please get the state of being able to gripping wire before starting repair.
- ※Please avoid pulling off terminal by force.
- ※When repairing, please be careful not to deform or scratch terminal lance.
- ※DO NOT REUSE the housing that withdrew terminals.

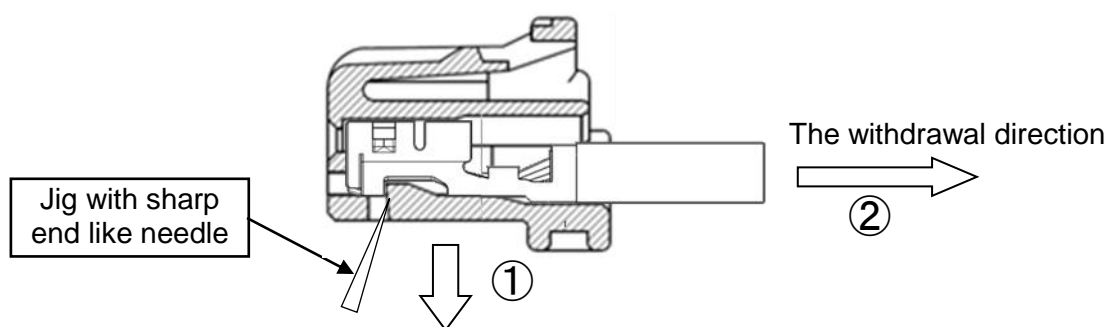

Fig.6-6

REVISION: A	ECM INFORMATION: EC No: 629338 DATE: 2019/12/24	TITLE: 2.0MM PITCH W/B CONN. DURACLIC™ SERIES	SHEET No. 19 of 30		
DOCUMENT NUMBER: AS-505151-002	DOC TYPE: PS	DOC PART: 001	CREATED / REVISED BY: MSATO08	CHECKED BY: HIIJIMA	APPROVED BY: TOSADA

6-3. Insertion of retainer (option)

- ① Hold the receptacle housing and the retainer by pinching right and left side.
- ② Insert the retainer from the direction indicated at **Fig.6-7**. It makes easier to insert that the retainer's comb is along wires. (**Fig.6-8**)
- ③ Insert its lock along the guide rib of receptacle housing, and load the retainer slowly and straightly till the lock is hanged completely. (**Fig.6-9**)

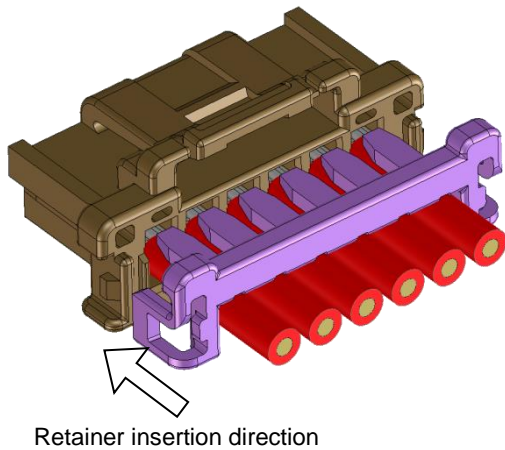

Fig.6-7

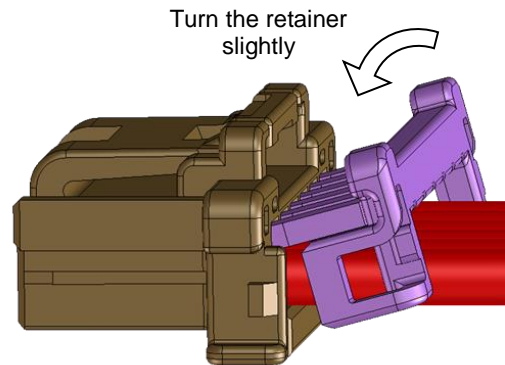

Fig.6-8

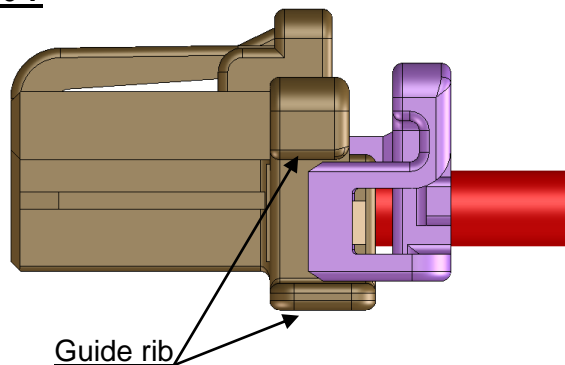

Fig.6-9

Instruction

- ※The retainer is optional part. You can use connectors without retainer. However, it assures terminal insertion and will reduce the possibility of terminal dropout.
- ※If you feel unusual such as hooking during the insertion, please do not continue by force. After confirming there is no damage of retainer or receptacle housing, it can be inserted again. If the damage is found, do not use the retainer and receptacle housing.

REVISION: A	ECM INFORMATION: EC No: 629338 DATE: 2019/12/24	TITLE: 2.0MM PITCH W/B CONN. DURACLIC™ SERIES	SHEET No. 20 of 30		
DOCUMENT NUMBER: AS-505151-002	DOC TYPE: PS	DOC PART: 001	CREATED / REVISED BY: MSATO08	CHECKED BY: HIIJIMA	APPROVED BY: TOSADA

- ④ After loading, please confirm with eyes the following state is not found: the lock is over the nail of receptacle housing (Fig.6-11), the retainer is bending (Fig.6-12). Refer to Fig.6-10.

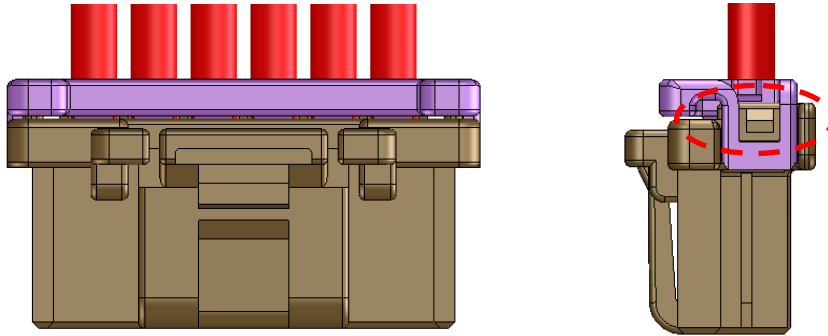
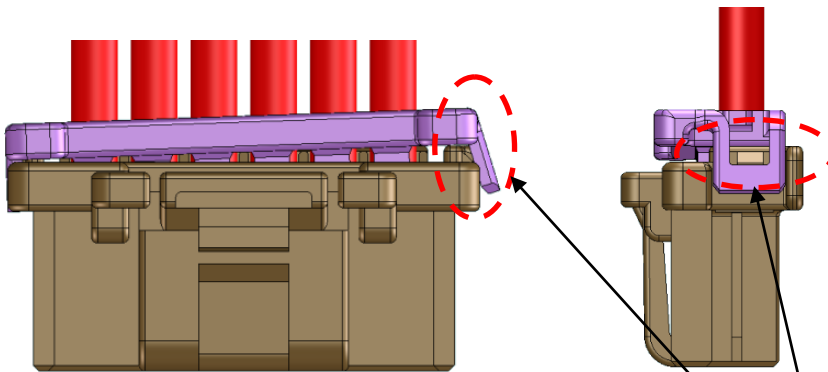

Fig.6-10 the state of inserted retainer rightly



The lock is over the nail of HSG and it is not be latched



Fig.6-11 the state that the lock is over the nail of receptacle housing

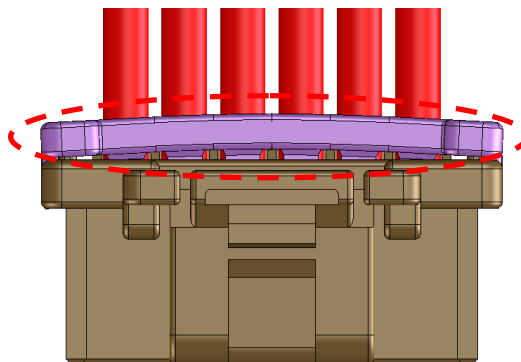

Fig.6-12 the state that the retainer is bending

REVISION: A	ECM INFORMATION: EC No: 629338 DATE: 2019/12/24	TITLE: 2.0MM PITCH W/B CONN. DURACLIC™ SERIES	SHEET No. 21 of 30		
DOCUMENT NUMBER: AS-505151-002	DOC TYPE: PS	DOC PART: 001	CREATED / REVISED BY: MSATO08	CHECKED BY: HIIJIMA	APPROVED BY: TOSADA

6-4. Repair of retainer (Option)

When you withdraw the retainer inserted once, please withdraw it with raising retainer's both locks using like flat-blade driver that is equal or less than $\phi 2$ mm.

However, the lock might be transformed by being raised. As strength of the transformed locks decreases extremely, the retainer might come off easily from housing even if you insert it again.

Therefore, please be sure to change the retainer to a new one when you repair it.

Inspection

- ※Must withdraw the retainer with raising retainer's BOTH locks.
- ※Please avoid pulling off the retainer by force. It might causes to damage receptacle housing, terminals, or retainer.
- ※DO NOT REUSE the retainer that be withdrawn.

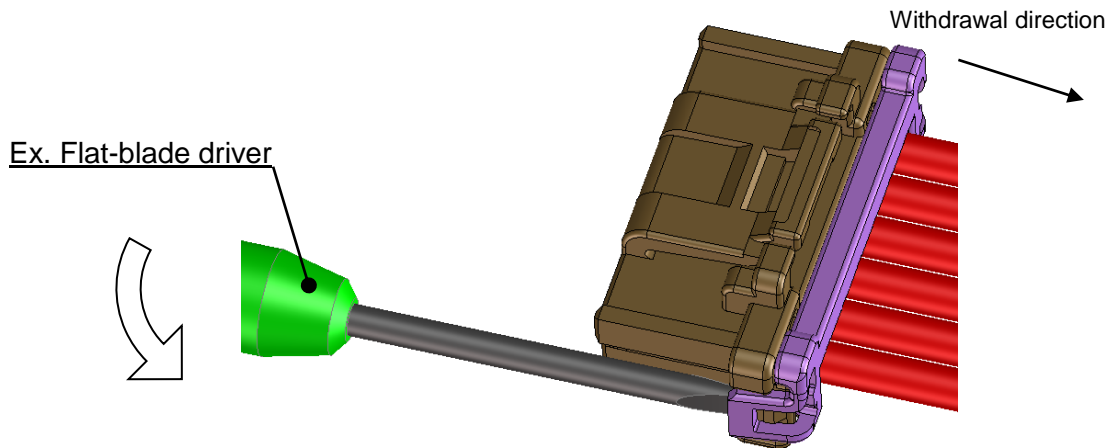

Fig.6-12

REVISION: A	ECM INFORMATION: EC No: 629338 DATE: 2019/12/24	TITLE: 2.0MM PITCH W/B CONN. DURACLIK™ SERIES	SHEET No. 22 of 30		
DOCUMENT NUMBER: AS-505151-002	DOC TYPE: PS	DOC PART: 001	CREATED / REVISED BY: MSATO08	CHECKED BY: HIIJIMA	APPROVED BY: TOSADA

【7. Banding of harness】

When banding harness after processing, please be careful with the following point.

- ① Please bundle the wires at more than 50mm away from connector and uniformize the force applied to each wire. (Fig.7-1)
- ② As for the harness, please do not apply force to only one wire (or a few particular wires). (Fig.7-2)

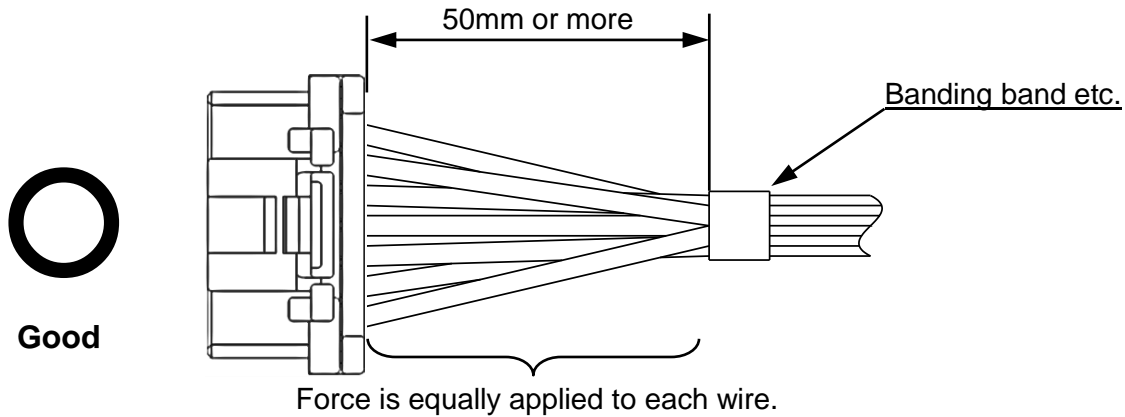

Fig.7-1 Harness is bundled properly

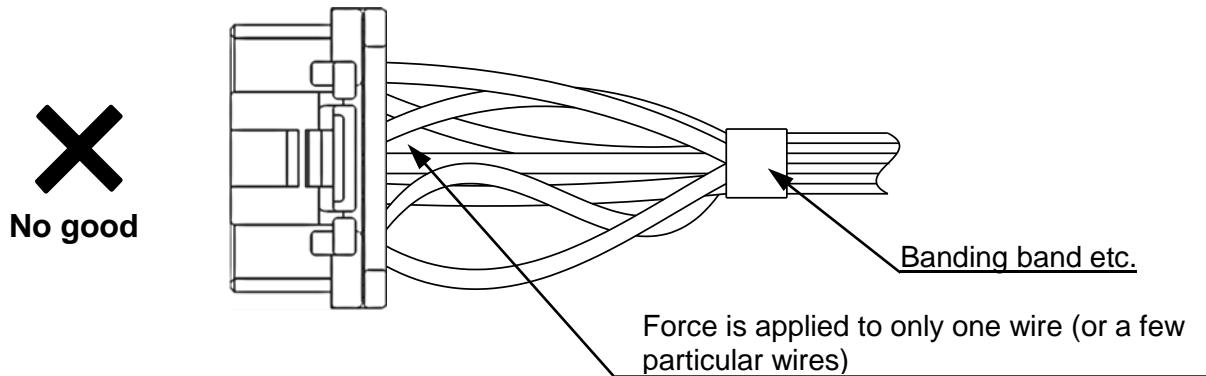

Fig.7-2 Harness is bundled improperly

Instruction

- ※When harnesses have tangled with each other, please do not pull them by force. That might damage to connector because the extreme force is applied to terminal and it might come off from connector.
- ※Please do not drop the product or hit it against other objects.

REVISION: A	ECM INFORMATION: EC No: 629338 DATE: 2019/12/24	TITLE: 2.0MM PITCH W/B CONN. DURACLIK™ SERIES	SHEET No. 23 of 30		
DOCUMENT NUMBER: AS-505151-002	DOC TYPE: PS	DOC PART: 001	CREATED / REVISED BY: MSATO08	CHECKED BY: HIIJIMA	APPROVED BY: TOSADA

【8. Recommended packaging of cable harness and assemblies】

When packing harness after processing, procedure and instruction (※) are shown below.

- ① Bundle the harness after processing. **Please band 20 harness at most in one bunch.**

Inspection

※When bundle the harness, in order to avoid applying excessive force constantly please do not use anything that fastens tightly such as rubber band. Please band at the center (at one point) with vinyl string. Please take a measure to protect connector from shock or load by wrapping each bunch of connector with air packing. **(Fig.8-1)**

When some harnesses are banded, each connector contact and part of lock might be loaded. In that case, deformation of lock part etc. might cause defective performance because the lock being down all the time. **(Fig.8-2)**

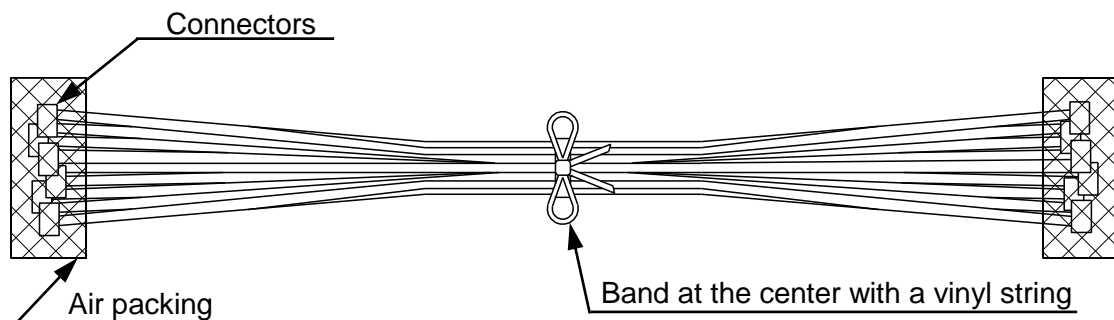

Fig.8-1 A bunch of harness

Do not apply load to the lock part.
(Include root part)

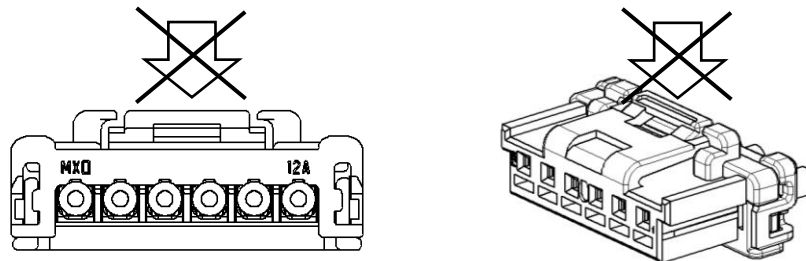

Fig.8-2 Precautions for connectors when packing.

REVISION: A	ECM INFORMATION: EC No: 629338 DATE: 2019/12/24	TITLE: 2.0MM PITCH W/B CONN. DURA CLIK™ SERIES	SHEET No. 24 of 30		
DOCUMENT NUMBER: AS-505151-002	DOC TYPE: PS	DOC PART: 001	CREATED / REVISED BY: MSATO08	CHECKED BY: HIIJIMA	APPROVED BY: TOSADA

- ① Put banded harness into carton box.
Figure below (Fig 8-3) Please take a measure not to add force to connector for a long period of time by stacking if you pack by different packing method for long harness.

Instruction

- ※When packing bundle of harness after processing in a package box, please follow instructed packaging and avoid applying excessive load or force to harnesses. (cross shape) (Fig.8-3 ①)
- ※Please lay air packing etc. on the bottom of package box. In order to prevent force from applying to connectors for a long time by piling up package boxes, please lay air packing etc. (Fig.8-3 ②)

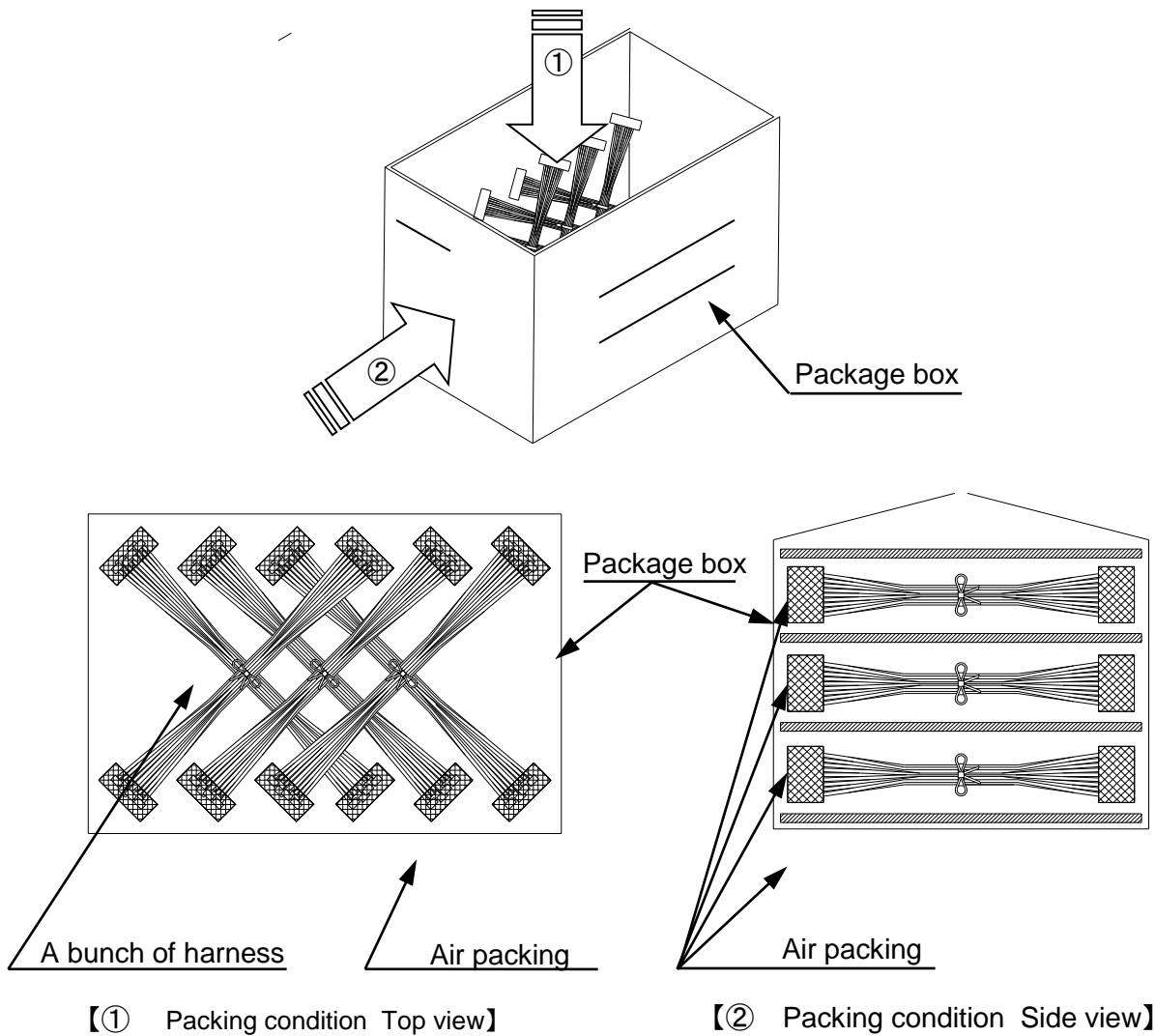

Fig.8-3 Packing condition

REVISION: A	ECM INFORMATION: EC No: 629338 DATE: 2019/12/24	TITLE: 2.0MM PITCH W/B CONN. DURA CLIK™ SERIES	SHEET No. 25 of 30		
DOCUMENT NUMBER: AS-505151-002	DOC TYPE: PS	DOC PART: 001	CREATED / REVISED BY: MSATO08	CHECKED BY: HIIJIMA	APPROVED BY: TOSADA

【9. Instruction when mating with HDR connector】

9-1. Recommended mating method

- ① Please set mating direction of receptacle housing (harness side) and plug housing (header side), and push both sides of receptacle housing to pitch direction (as shown with arrows) **until both connectors meet each other (complete mating position).**
- ② After mating, please confirm that the lock has fastened completely.

Please push both sides of receptacle housing and insert.

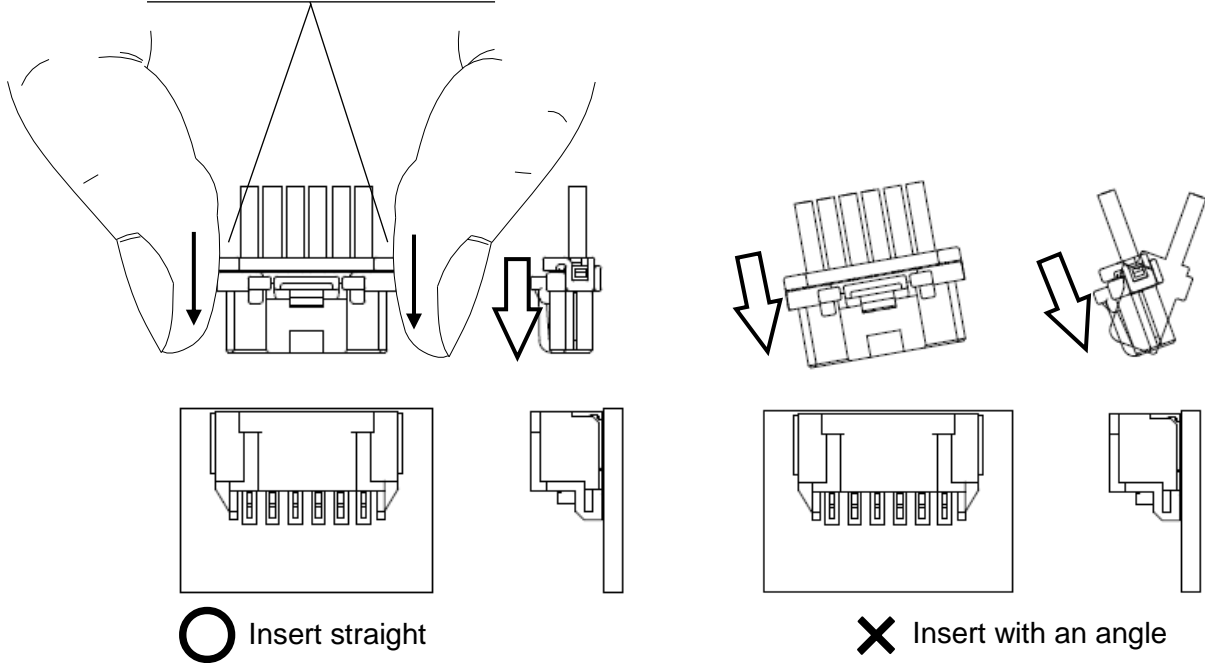

○ Insert straight

Fig.9-1

✗ Insert with an angle

Fig.9-2

Inspection

- ※When mating, please do not push positive lock of receptacle housing. It prevents the lock part of correct movement, and it might damage by being applied excessive load or might leave half-mating.
- ※Please push receptacle housing and insert it straightly until they touch each other. If you cannot insert smoothly, please insert again after confirming if there is no transformation of terminal and receptacle housing etc.
- ※After insertion, please confirm not to come off connectors with pulling all wires lightly (about 2~3 N). When pulling wires, you should care not to apply the force to particular wire. Additionally, please confirm visually that the lock release position of receptacle housing returns to original position. (**Fig.9-3**) If not, it might be incompleting mating. Please withdraw the connector according to Section 9-2, and check the terminals that have transformation.

REVISION: A	ECM INFORMATION: EC No: 629338 DATE: 2019/12/24	TITLE: 2.0MM PITCH W/B CONN. DURA CLIK™ SERIES	SHEET No. 26 of 30
DOCUMENT NUMBER: AS-505151-002	DOC TYPE: PS	DOC PART: 001	CREATED / REVISED BY: MSATO08
	CHECKED BY: HIIJIMA	APPROVED BY: TOSADA	

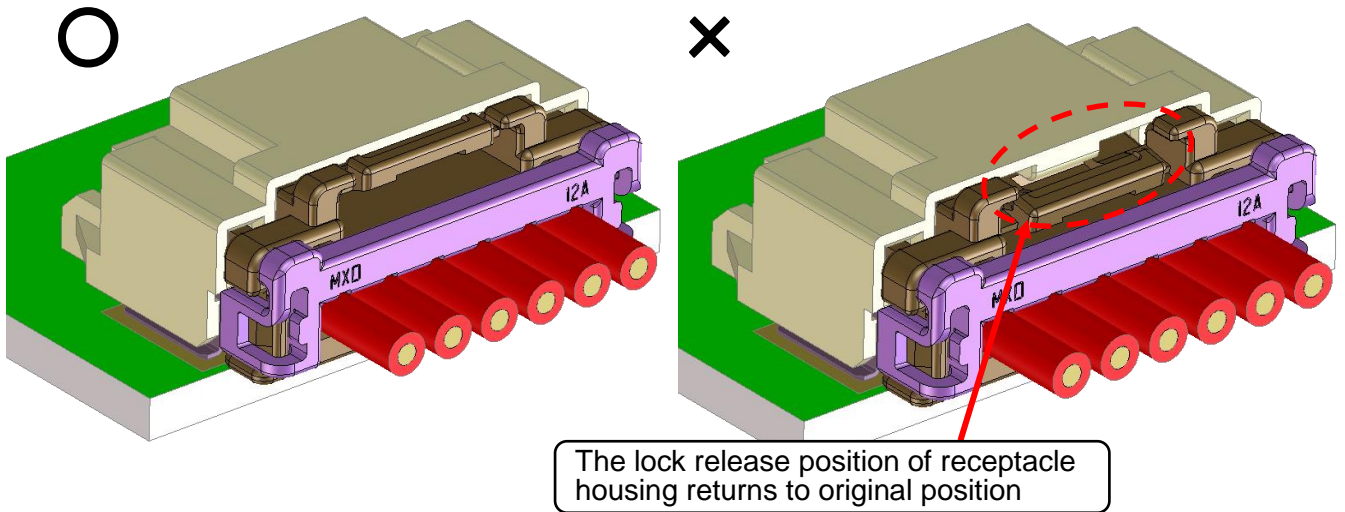

Fig.9-3 Confirmation of

9-2. Recommended withdrawal method

Please hold wires all together lightly. After releasing lock completely by attaching fingers to the lock and pushing bar for releasing lock using flat part of finger, please withdraw receptacle housing slowly, axially and straightly. Please avoid withdrawing them with an angle and roughly. That might cause damage to connector.

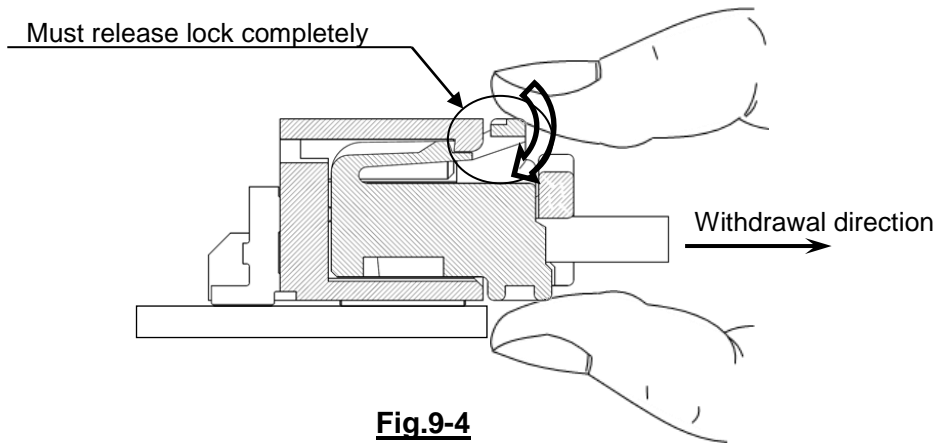

Fig.9-4

Instruction

- ※Please do not withdraw with holding only a few particular wires. As excessive force is applied to particular terminals, the connector might be damaged or a terminal might come off.
- ※When withdrawing, please release the lock completely. This product has the structure of connector coming off prevention that depends on positive lock. If you pull off it by force, without the lock releases incompletely, the connector might damage.

REVISION: A	ECM INFORMATION: EC No: 629338 DATE: 2019/12/24	TITLE: 2.0MM PITCH W/B CONN. DURACLIC™ SERIES	SHEET No. 27 of 30		
DOCUMENT NUMBER: AS-505151-002	DOC TYPE: PS	DOC PART: 001	CREATED / REVISED BY: MSATO08	CHECKED BY: HIIJIMA	APPROVED BY: TOSADA

9-3. Wiring after mating

Inspection

- ※If you plan on pulling around wires inside machine, please take measures to prevent force from applying to connectors directly, such as allowing wires to have enough flexibility. **(Fig.9-3-1)**
- ※When pulling wires around inside actual machine, please do not use under the condition that wires are bent excessively or tension is added. That might be reason for terminal to be pulled out because force is added to terminal crimping zone or terminal insertion portion of receptacle by wire tension. Especially, please prevent force from being applied to only a few particular wires. **(Fig.9-3-2)**
- ※If force is added to one particular wire, wire(crimp terminal) might be pulled off.
- ※Wire routing inside customer's device needs to avoid excessive stress. Please avoid pulling them toward more than two directions. **(Fig.9-3-3)**
- ※If you plan on special wiring inside customer's device, please contact us before using. **(Fig9-3-2/9-3-3 etc.)**

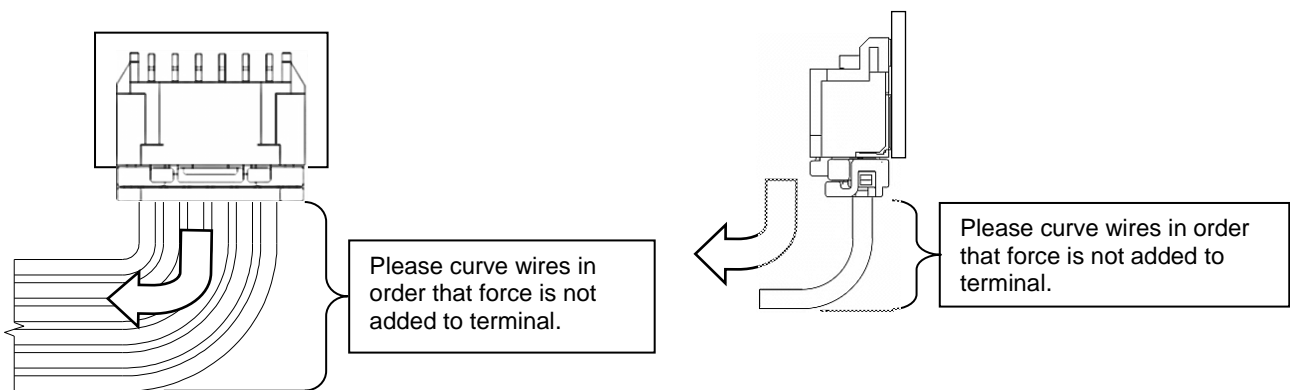

Fig.9-3-1 Condition wires are curved

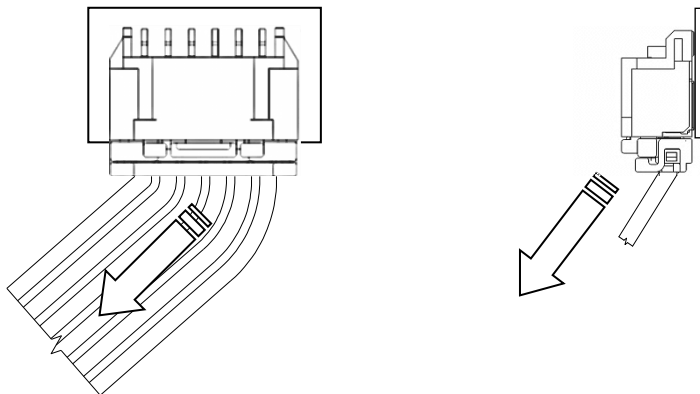
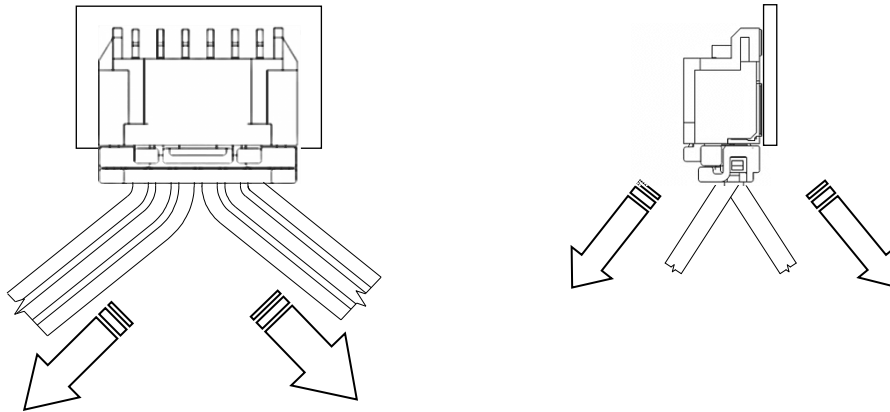

Fig.9-3-2 Condition wires are bent excessively or tension is added

REVISION: A	ECM INFORMATION: EC No: 629338 DATE: 2019/12/24	TITLE: 2.0MM PITCH W/B CONN. DURACLIK™ SERIES	SHEET No. 28 of 30		
DOCUMENT NUMBER: AS-505151-002	DOC TYPE: PS	DOC PART: 001	CREATED / REVISED BY: MSATO08	CHECKED BY: HIIJIMA	APPROVED BY: TOSADA



× Fig.9-3-3 Wiring toward more than 2 directions

REVISION: A	ECM INFORMATION: EC No: 629338 DATE: 2019/12/24	TITLE: 2.0MM PITCH W/B CONN. DURACLIK™ SERIES	SHEET No. 29 of 30
DOCUMENT NUMBER: AS-505151-002	DOC TYPE: PS	DOC PART: 001	CREATED / REVISED BY: MSATO08
	CHECKED BY: HIJIMA	APPROVED BY: TOSADA	

