

NOTES

1. RE DETAILED DIMENSION, SEE PRODUCT DRAWING.
  2. NUMBER OF CONNECTORS : SEE CHART
  3. LEAD TAPE LENGTH
- 
4. TOP TAPE PEEL FORCE IS DEFINED BY IEC60286-3.
  5. MATERIAL  
 CARRIER TAPE : POLYSTYRENE  
 TOP TAPE : PET , OTHER  
 REEL : POLYSTYRENE (PS) < RECYCLE MATERIAL CONTAINED >
  6. ELV AND RoHS COMPLIANT

$\phi 380$	7000	10 ~ 70
		6
(D)	NUMBER OF CONNECTORS [PCS/REEL]	CIRCUIT

MODEL NO. 505413\*\*10

THIS DRAWING CONTAINS INFORMATION THAT IS PROPRIETARY TO MOLEX ELECTRONIC TECHNOLOGIES, LLC AND SHOULD NOT BE USED WITHOUT WRITTEN PERMISSION		CURRENT REV DESC: REVISED		<b>molex</b>	
DIMENSION UNITS	SCALE				
mm	1:1			0.35 BB H=1.0 SSB10RP REC EMBSTP PKG	
GENERAL TOLERANCES (UNLESS SPECIFIED)		EC NO: 612114		PRODUCT CUSTOMER DRAWING	
ANGULAR TOL	$\pm 3.0^\circ$	DRWN: ABABU01	2019/02/13	DOCUMENT NUMBER	
4 PLACES	$\pm 0.03$	CHK'D: MSASAO	2019/02/15	DOC TYPE	
3 PLACES	$\pm 0.03$	APPR: MSASAO	2019/02/18	DOC PART	
2 PLACES	$\pm 0.05$	INITIAL REVISION:		REVISION	
1 PLACE	$\pm 0.1$	DRWN: HONO01	2016/03/16	5054130000	
0 PLACES	$\pm 0.2$	APPR: KMORIKAWA	2016/04/26	PSD	000
DRAFT WHERE APPLICABLE MUST REMAIN WITHIN DIMENSIONS		THIRD ANGLE PROJECTION	DRAWING	SERIES	MATERIAL NUMBER
			A3-SIZE	505413	CUSTOMER
					GENERAL
					SHEET NUMBER
					1 OF 4

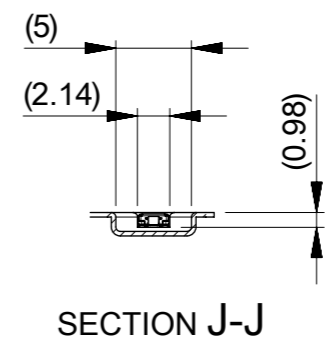
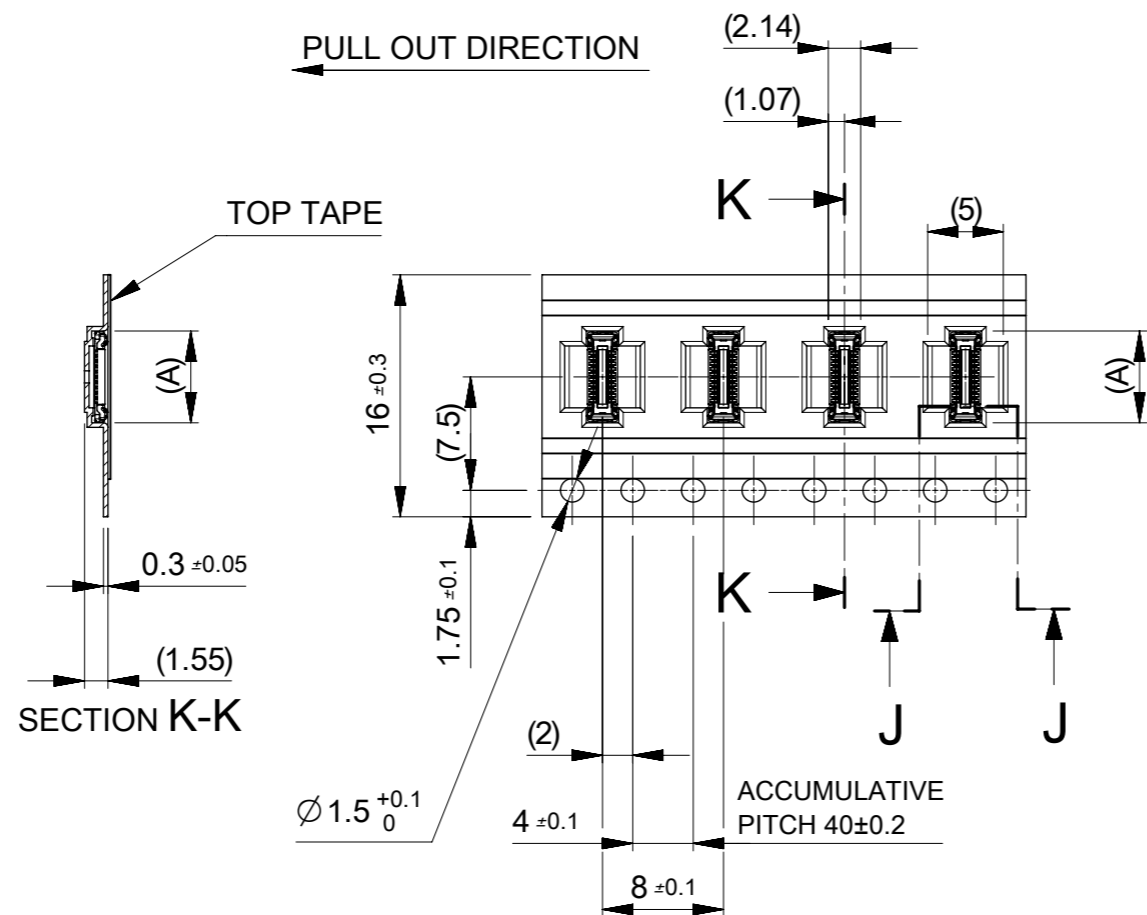

16	21.4	17.4	7.82	5054133010	○	---	30
			6.77	5054132410	---	---	24
			6.42	5054132210	---	---	22
			6.07	5054132010	---	---	20
			5.72	5054131810	---	---	18
			5.37	5054131610	---	---	16
			5.02	5054131410	---	---	14
			4.67	5054131210	---	---	12
			4.32	5054131010	---	---	10
3.62	5054130610	○	---	6			
キャリアテープ幅 CARRIER TAPE WIDTH	C	B	(A)	EMBOSSED TAPE PACKAGE	HIGH VOL. TOOL	LOW VOL. TOOL	CIRCUIT
ORDER NO.	SAMPLE PREPARATION ○:TOOLED △:WORK IN PROCESS ---:TOOLING TO BE CONFIRMED						

THIS DRAWING CONTAINS INFORMATION THAT IS PROPRIETARY TO MOLEX ELECTRONIC TECHNOLOGIES, LLC AND SHOULD NOT BE USED WITHOUT WRITTEN PERMISSION

DIMENSION UNITS mm	SCALE 2:1	CURRENT REV DESC: REVISED		<b>molex</b>		
GENERAL TOLERANCES (UNLESS SPECIFIED)		EC NO: 612114				
ANGULAR TOL	± 3.0°	DRWN: ABABU01	2019/02/13	PRODUCT CUSTOMER DRAWING		
4 PLACES	± 0.03	CHK'D: MSASAO	2019/02/15	DOCUMENT NUMBER		
3 PLACES	± 0.03	APPR: MSASAO	2019/02/18	5054130000		
2 PLACES	± 0.05	INITIAL REVISION:		DOC TYPE	DOC PART	REVISION
1 PLACE	± 0.1	DRWN: HONO01	2016/03/16	PSD	000	G1
0 PLACES	± 0.2	APPR: KMORIKAWA	2016/04/26	SHEET NUMBER		
DRAFT WHERE APPLICABLE MUST REMAIN WITHIN DIMENSIONS		THIRD ANGLE PROJECTION	DRAWING	SERIES	MATERIAL NUMBER	CUSTOMER
			A3-SIZE	505413	SEE CHART	GENERAL

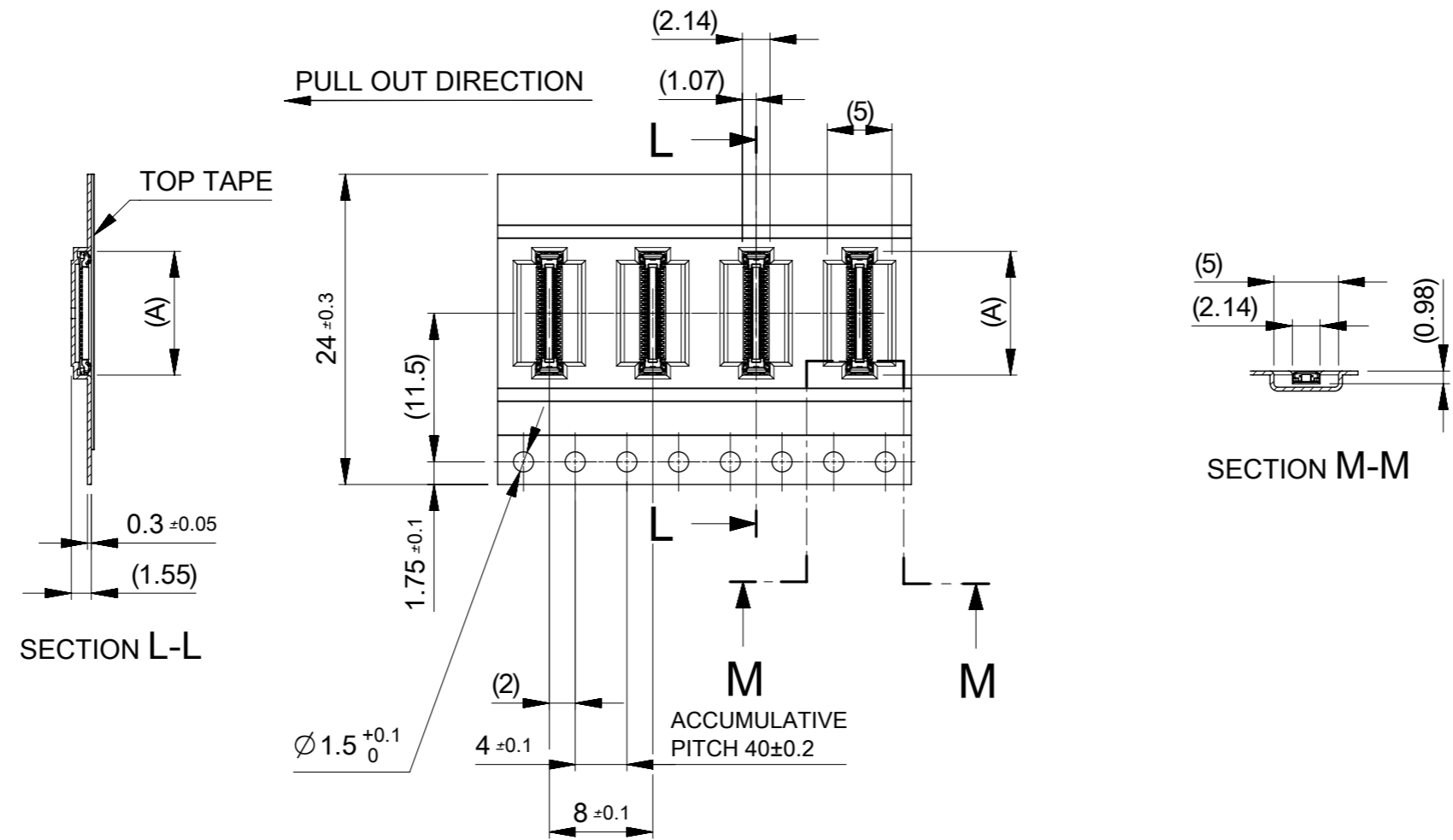

24	29.4	25.4	13.42	5054136410	---	---	64
			12.72	5054136010	○	---	60
			12.02	5054135410	---	---	54
			11.32	5054135010	---	---	50
			10.97	5054134810	---	---	48
			10.62	5054134610	---	---	46
			9.92	5054134210	---	---	42
			9.57	5054134010	○	---	40
			8.52	5054133410	○	---	34
キャリアテープ幅 CARRIER TAPE WIDTH	C	B	(A)	EMBOSSED TAPE PACKAGE	HIGH VOL. TOOL	LOW VOL. TOOL	CIRCUIT
ORDER NO.	SAMPLE PREPARATION ○:TOOLED △:WORK IN PROCESS ---:TOOLING TO BE CONFIRMED						

THIS DRAWING CONTAINS INFORMATION THAT IS PROPRIETARY TO MOLEX ELECTRONIC TECHNOLOGIES, LLC AND SHOULD NOT BE USED WITHOUT WRITTEN PERMISSION

DIMENSION UNITS mm	SCALE 2:1	CURRENT REV DESC: REVISED		<b>molex</b>		
GENERAL TOLERANCES (UNLESS SPECIFIED)		EC NO: 612114				
ANGULAR TOL	± 3.0 °	DRWN: ABABU01	2019/02/13	PRODUCT CUSTOMER DRAWING		
4 PLACES	± 0.03	CHK'D: MSASAO	2019/02/15	DOCUMENT NUMBER		
3 PLACES	± 0.03	APPR: MSASAO	2019/02/18	5054130000		
2 PLACES	± 0.05	INITIAL REVISION:		DOC TYPE	DOC PART	REVISION
1 PLACE	± 0.1	DRWN: HONO01	2016/03/16	PSD	000	G1
0 PLACES	± 0.2	APPR: KMORIKAWA	2016/04/26	SHEET NUMBER		
DRAFT WHERE APPLICABLE MUST REMAIN WITHIN DIMENSIONS	THIRD ANGLE PROJECTION	DRAWING	SERIES	MATERIAL NUMBER	CUSTOMER	SHEET NUMBER
		A3-SIZE	505413	SEE CHART	GENERAL	3 OF 4

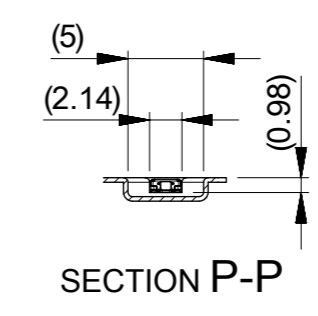
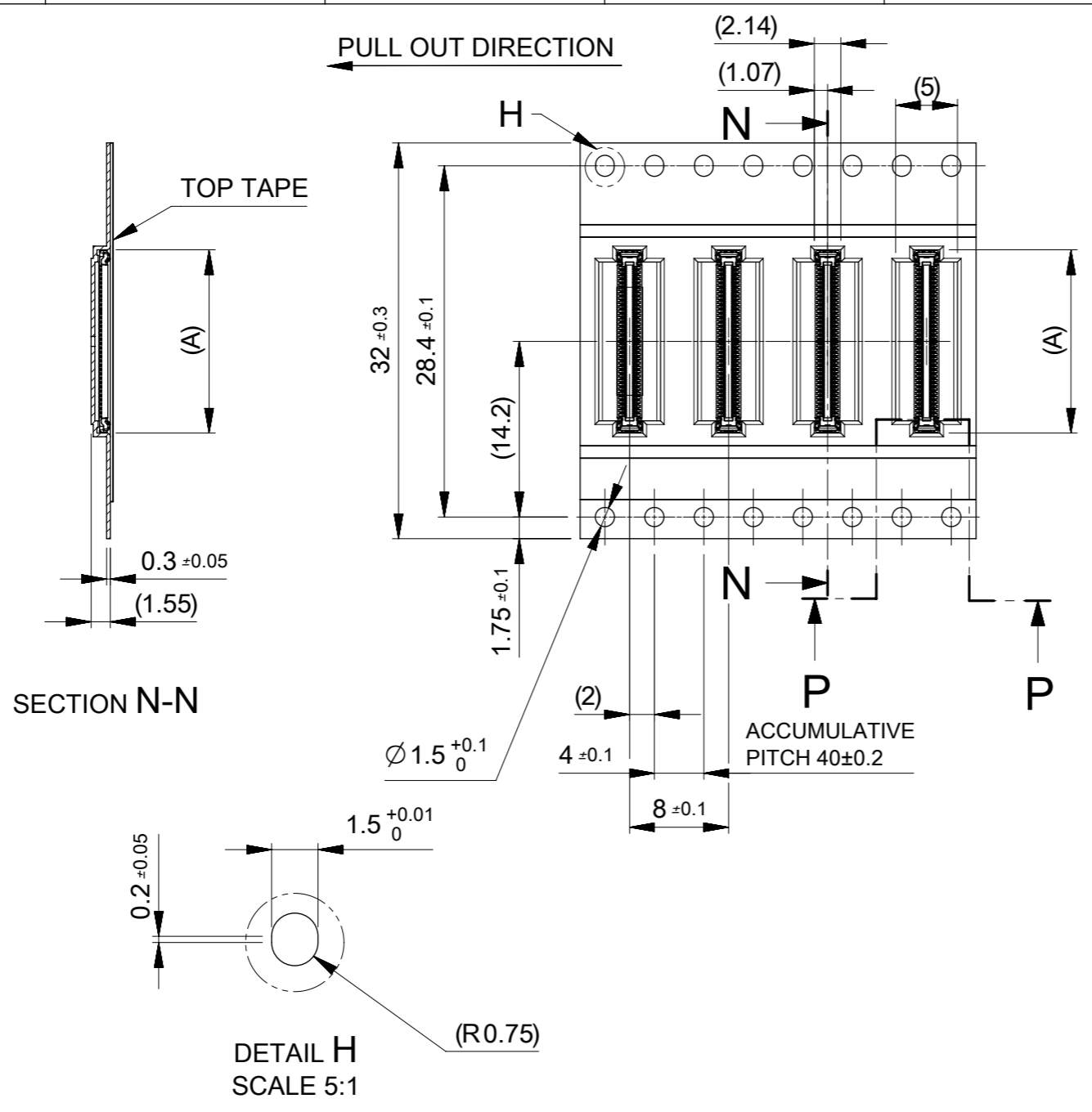

32	37.4	33.4	14.82	5054137010	---	---	70
キャリアテープ幅 CARRIER TAPE WIDTH	C	B	(A)	EMBOSSED TAPE PACKAGE	HIGH VOL. TOOL	LOW VOL. TOOL	CIRCUIT
				ORDER NO.	SAMPLE PREPARATION ○:TOOLED △:WORK IN PROCESS ---:TOOLING TO BE CONFIRMED		

THIS DRAWING CONTAINS INFORMATION THAT IS PROPRIETARY TO MOLEX ELECTRONIC TECHNOLOGIES, LLC AND SHOULD NOT BE USED WITHOUT WRITTEN PERMISSION							
DIMENSION UNITS mm	SCALE 2:1	CURRENT REV DESC: REVISED			<b>molex</b>		
GENERAL TOLERANCES (UNLESS SPECIFIED)		EC NO: 612114					
ANGULAR TOL	± 3.0 °	DRWN: ABABU01	2019/02/13	PRODUCT CUSTOMER DRAWING			
4 PLACES	± 0.03	CHK'D: MSASAO	2019/02/15	DOCUMENT NUMBER			
3 PLACES	± 0.03	APPR: MSASAO	2019/02/18	5054130000			
2 PLACES	± 0.05	INITIAL REVISION:		DOC TYPE	DOC PART	REVISION	
1 PLACE	± 0.1	DRWN: HONO01	2016/03/16	PSD	000	G1	
0 PLACES	± 0.2	APPR: KMORIKAWA	2016/04/26	SHEET NUMBER			
DRAFT WHERE APPLICABLE MUST REMAIN WITHIN DIMENSIONS		THIRD ANGLE PROJECTION	DRAWING	SERIES	MATERIAL NUMBER	CUSTOMER	
			A3-SIZE	505413	SEE CHART	GENERAL	4 OF 4

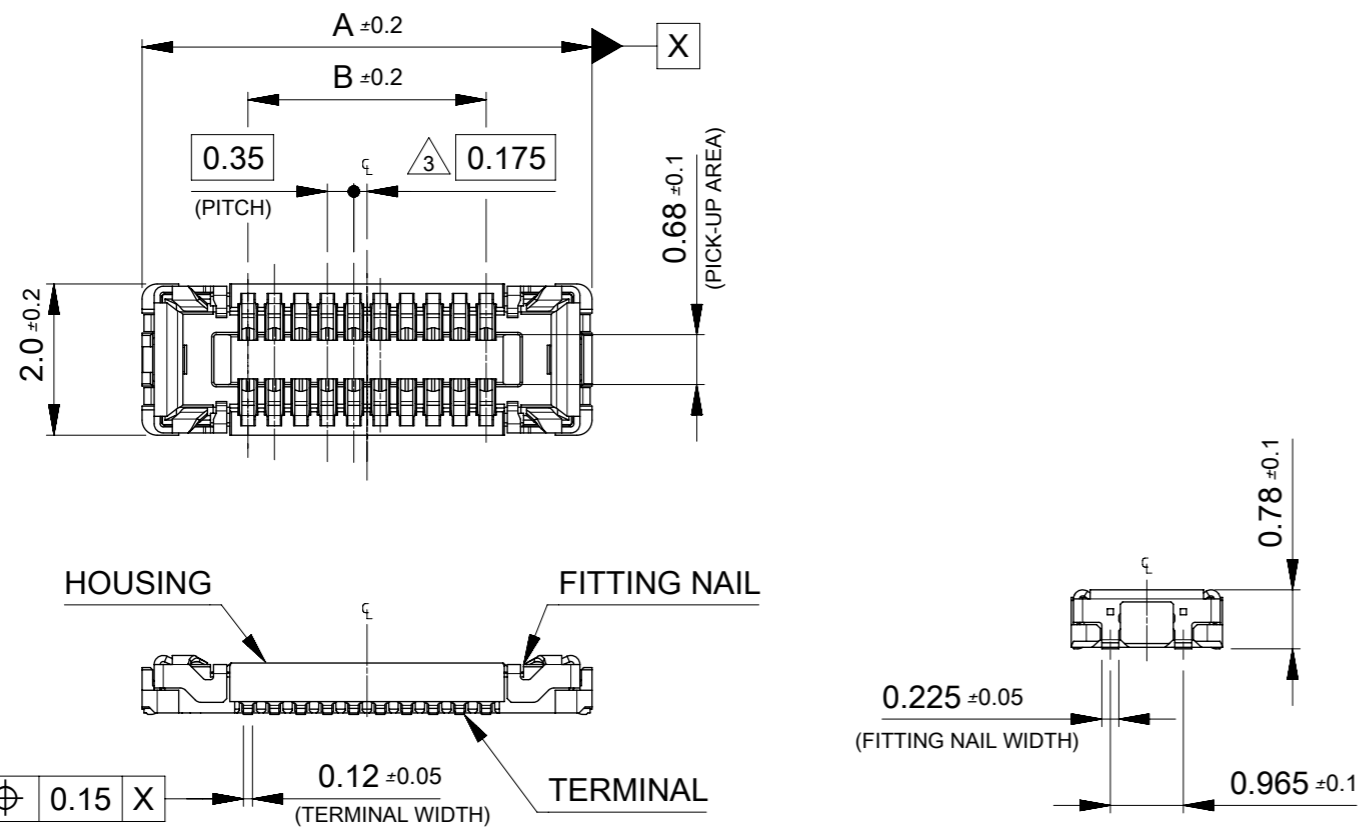

**NOTES**

1. MATERIAL  
HOUSING : LIQUID CRYSTAL POLYMER UL94V-0(COLOR : BLACK)  
TERMINAL : COPPER ALLOY  
FITTING NAIL : COPPER ALLOY
2. PLATING  
TERMINAL :  
GOLD  
UNDER PLATING : NICKEL  
\*DIVIDE INTO PARTS THE GOLD PLATING OF THE CONTACT AND THE TAIL PART BY THE NICKEL PLATING.
- FITTING NAIL :  
GOLD(ONLY CONTACT AND TAIL PART)  
UNDER PLATING : NICKEL
- △<sub>3</sub> APPLY FOR (CIRCUIT/2)=EVEN
4. MATE WITH : 505417\*\*10
5. TAIL AND FITTING NAIL COPLANARITY TO BE 0.08MAXIMUM.
- △<sub>6</sub> PROHIBITED AREA OF PATTERN WIRING AND SOLDER.  
(FOR EACH AREA, THE WIRING THAT TOUCHES ON THE SOLDER CAN BE ATTACHED, THEN COVERED WITH A FILM TO KEEP SOLDER OUT.)
7. ELV and RoHS COMPLIANT.

11.90	14.70	5054137010	---	---	70
10.85	13.65	5054136410	---	---	64
10.15	12.95	5054136010	○	---	60
9.10	11.90	5054135410	---	---	54
8.40	11.20	5054135010	---	---	50
8.05	10.85	5054134810	---	---	48
7.70	10.50	5054134610	---	---	46
7.00	9.80	5054134210	---	---	42
6.65	9.45	5054134010	○	---	40
5.60	8.40	5054133410	○	---	34
4.90	7.70	5054133010	○	---	30
3.85	6.65	5054132410	---	---	24
3.50	6.30	5054132210	---	---	22
3.15	5.95	5054132010	---	---	20
2.80	5.60	5054131810	---	---	18
2.45	5.25	5054131610	---	---	16
2.10	4.90	5054131410	○	---	14
1.75	4.55	5054131210	---	---	12
1.40	4.20	5054131010	---	---	10
0.70	3.50	5054130610	○	---	6

B	A	EMBOSSED TAPE PACKAGE	MASS PRODUCTION	LOW VOL.TOOL	CIRCUIT
		ORDER No.	SMAPLE PREPARATION ○:TOOLED △:WORK IN PROCESS ---:TOOLING TO BE CONFIRMED		
		CONNECTOR SERIES No. : 505413**09			

THIS DRAWING CONTAINS INFORMATION THAT IS PROPRIETARY TO MOLEX ELECTRONIC TECHNOLOGIES, LLC AND SHOULD NOT BE USED WITHOUT WRITTEN PERMISSION					
DIMENSION UNITS	SCALE	CURRENT REV DESC:			
mm	10:1	<p>0.35 BB CONN. H=1.0 SSB10RP REC. ASSY</p> <p>PRODUCT CUSTOMER DRAWING</p>			
GENERAL TOLERANCES (UNLESS SPECIFIED)					
ANGULAR TOL	± 3.0 °				
4 PLACES	± 0.03				
3 PLACES	± 0.03				
2 PLACES	± 0.05				
1 PLACE	± 0.1	INITIAL REVISION:		DOCUMENT NUMBER	DOC TYPE
0 PLACES	± 0.2	DRWN: HONO01 2016/04/25		5054131000	PSD
DRAFT WHERE APPLICABLE MUST REMAIN WITHIN DIMENSIONS		THIRD ANGLE PROJECTION	DRAWING	SERIES	MATERIAL NUMBER
			A3-SIZE	505413	SEE CHART
				CUSTOMER	SHEET NUMBER
				GENERAL	1 OF 2

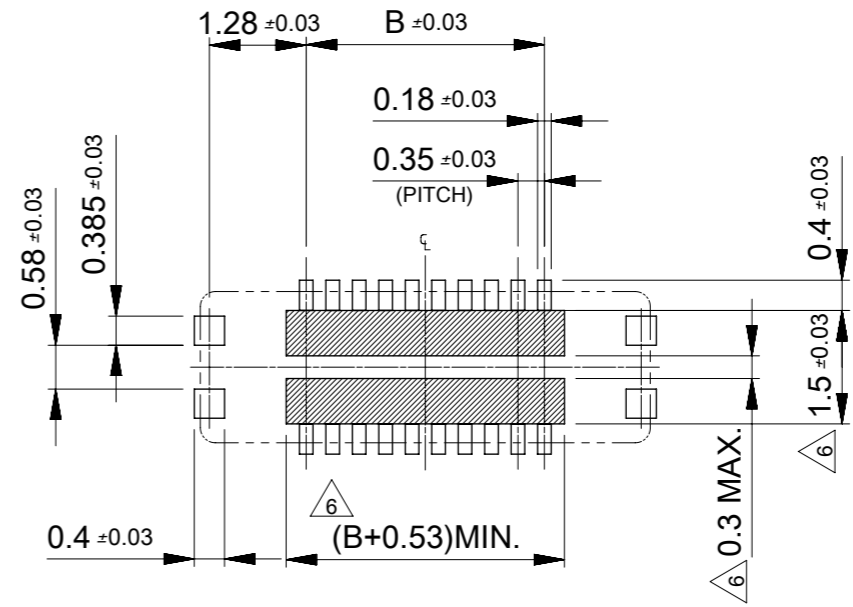

RECOMMENDED P.W.BOARD PATTERN LAYOUT (REFERENCE)

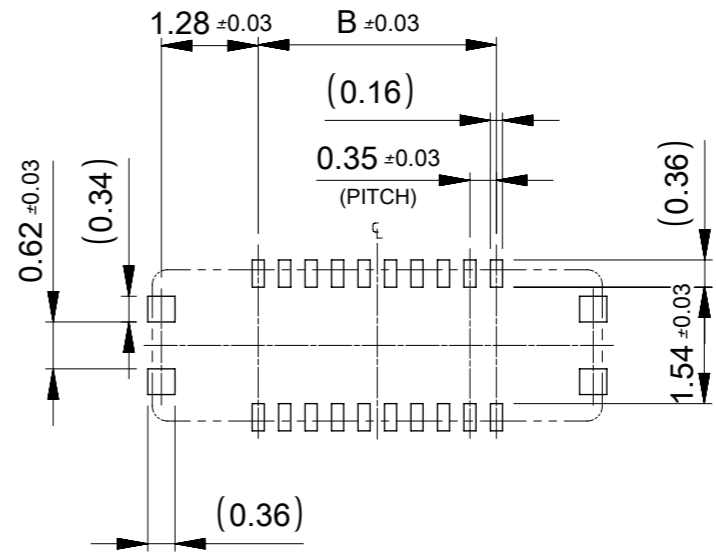
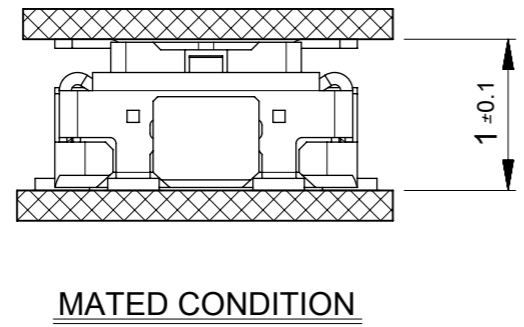

RECOMMENDED METAL MASK LAYOUT (REFERENCE)  
 RECOMMENDED THICKNESS OF METAL MASK : t=0.08mm  
 RECOMMENDED OPEN APERTURE RATIO OF METAL MASK : 80%

THIS DRAWING CONTAINS INFORMATION THAT IS PROPRIETARY TO MOLEX ELECTRONIC TECHNOLOGIES, LLC AND SHOULD NOT BE USED WITHOUT WRITTEN PERMISSION									
DIMENSION UNITS		SCALE		CURRENT REV DESC:				<b>molex</b>	
mm		10:1							
GENERAL TOLERANCES (UNLESS SPECIFIED)				EC NO: 601150				0.35 BB CONN. H=1.0 SSB10RP REC. ASSY	
ANGULAR TOL ± 3.0°				DRWN: RMIYAMOTO 2018/07/09				PRODUCT CUSTOMER DRAWING	
4 PLACES ± 0.03				CHK'D: KSASAKI 2018/07/09				DOCUMENT NUMBER	
3 PLACES ± 0.03				APPR: TKUSUHARA01 2018/07/10				5054131000	
2 PLACES ± 0.05				INITIAL REVISION:				DOC TYPE	
1 PLACE ± 0.1				DRWN: HONO01 2016/04/25				PSD	
0 PLACES ± 0.2				APPR: KMORIKAWA 2016/04/26				DOC PART	
DRAFT WHERE APPLICABLE MUST REMAIN WITHIN DIMENSIONS				THIRD ANGLE PROJECTION		DRAWING		REVISION	
				A3-SIZE		SERIES		E	
				505413		MATERIAL NUMBER		SHEET NUMBER	
				SEE CHART		CUSTOMER		2 OF 2	
				GENERAL					