

Distributed by:

JAMECO[®]
ELECTRONICS

www.Jameco.com ♦ 1-800-831-4242

The content and copyrights of the attached
material are the property of its owner.

Jameco Part Number 884416

FEATURES AND SPECIFICATIONS

Features and Benefits

- Sizes 2 to 25 circuits
- Positive latch secures housing to locking crown of mating header or panel mount
- Anti-entanglement/overstress ribs prevent discrete wires from catching under latch during harness manufacturing and storage
- Front ribs prevent contact damage when unmating the connector from a header; the housing cannot be twisted off pins

Physical

Housing: Black glass-filled polyester, UL 94V-0
Operating Temperature: -40 to +105°C



2.54mm (.100") Pitch

SL™

Crimp Housing

70066

Single Row

Version G, Positive Latch

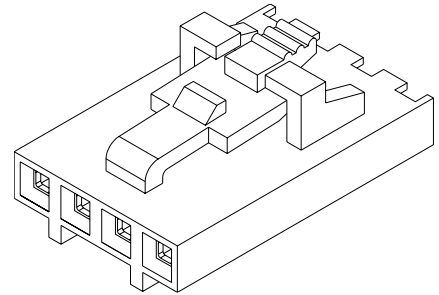

2.54mm (.100") Pitch

Reference Information

Product Specification: PS-70058

Packaging: Bag

UL File No.: E29179

CSA File No.: LR19980

Mates With: 70018, 70107A/B, 70541, 70543, 70545,

70551, 70553, 70555 and 70634

Use With: 70058 and 71851 crimp terminals

Designed In: Inches

CATALOG DRAWING (FOR REFERENCE ONLY)

Not For Use With C-Grid III™ Components

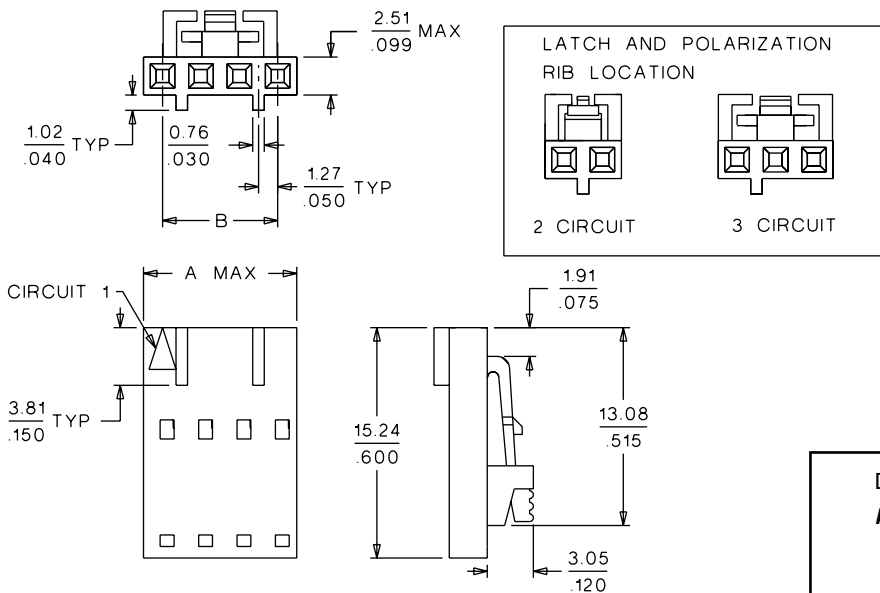

Delivered on a carrier with 20 pieces per strip.
Actual Size  **Universal Polarizing Pin 40713-1**
Order No. 15-04-0292

ORDERING INFORMATION AND DIMENSIONS

Circuits	Order No.	Dimension	
		A	B
2	• 50-57-9402	5.05 (.199)	2.54 (.100)
3	• 50-57-9403	7.59 (.299)	5.08 (.200)
4	• 50-57-9404	10.13 (.399)	7.62 (.300)
5	• 50-57-9405	12.67 (.499)	10.16 (.400)
6	• 50-57-9406	15.21 (.599)	12.70 (.500)
7	• 50-57-9407	17.75 (.699)	15.24 (.600)
8	• 50-57-9408	20.29 (.799)	17.78 (.700)
9	• 50-57-9409	22.83 (.899)	20.32 (.800)
10	• 50-57-9410	25.37 (.999)	22.86 (.900)
11	• 50-57-9411	27.91 (1.099)	25.40 (1.000)
12	• 50-57-9412	30.45 (1.199)	27.94 (1.100)
13	• 50-57-9413	32.99 (1.299)	30.48 (1.200)

Circuits	Order No.	Dimension	
		A	B
14	• 50-57-9414	35.53 (1.399)	33.02 (1.300)
15	• 50-57-9415	38.07 (1.499)	35.56 (1.400)
16	• 50-57-9416	40.61 (1.599)	38.10 (1.500)
17	• 50-57-9417	43.15 (1.699)	40.64 (1.600)
18	• 50-57-9418	45.69 (1.799)	43.18 (1.700)
19	• 50-57-9419	48.23 (1.899)	45.72 (1.800)
20	• 50-57-9420	50.77 (1.999)	48.26 (1.900)
21	• 50-57-9421	53.31 (2.099)	50.80 (2.000)
22	• 50-57-9422	55.85 (2.199)	53.34 (2.100)
23	• 50-57-9423	58.39 (2.299)	55.88 (2.200)
24	• 50-57-9424	60.93 (2.399)	58.42 (2.300)
25	• 50-57-9425	63.47 (2.499)	60.96 (2.400)

• US Standard Product, available through Molex franchised distributors



PRODUCT SPECIFICATION



LANGUAGE
ENGLISH

TABLE OF CONTENTS

<u>PARAGRAPH</u>	<u>DESCRIPTION</u>	<u>PAGE</u>
1.0	SCOPE	2
2.0	PRODUCT DESCRIPTION	2
3.0	APPLICABLE DOCUMENTS AND SPECIFICATIONS ..	4
4.0	RATINGS	4
5.0	PERFORMANCE	6
6.0	PACKAGING	9
7.0	QUALITY ASSURANCE PROVISIONS	9
8.0	QUALITY REQUIREMENTS	10
9.0	TEST SUMMARY	12

REV							
SHT							
REVISE ON PC ONLY			TITLE				
F	ADD PROCESS TEMPERATURE UDT2002-1016 RSFOX 2/13/02		PRODUCT SPECIFICATION SINGLE ROW – STACKABLE LINEAR-(SL) CONNECTOR SYSTEM				
			THIS DOCUMENT CONTAINS INFORMATION THAT IS PROPRIETARY TO MOLEX INC. AND SHOULD NOT BE USED WITHOUT WRITTEN PERMISSION				
REV	DESCRIPTION		WRITTEN BY:	CHECKED BY:	APPROVED BY:	DATE: YR / MO / DAY	
	DESIGN CONTROL	STATUS	FOX	STILES	BRINKMAN	99/11/16	
	LISLE					FILE NAME	SHT NO.
DOCUMENT NO. PS – 70400						PS-70400.LWP	1 OF 14
BORDER TEMPLATE: ES-40000-3996 REV. A SHEET 3 95/MAR/10 EC U5-0926 DCBRD03.LWP							



PRODUCT SPECIFICATION



LANGUAGE

ENGLISH

1.0 SCOPE

This specification is intended to define the mechanical, electrical and environmental requirements for the SL .100" (2.54) pitch modular, single row wire-to-board and wire-to-wire system.

SL is designed for high density signal applications. The system includes: low profile latching vertical and right angle headers; low profile housings for male and female crimp terminals; pre-assembled, single piece pin and receptacle connectors for Insulation Displacement Technology (IDT); panel mounts for modular wire-to-wire remote interconnections; and SL offers design flexibility and automated harness-making capabilities when combined with our tooling.

2.0 PRODUCT DESCRIPTION:

2.1 The following Series are covered by this product specification:

- 70021, male, crimp terminal
- 70058, female box, crimp terminal
- 71851, female box, high force crimp terminal
- 70066 & 70107, single row, crimp housing
- 70450, dual row, crimp housing
- 70400, female, single row, insulation displacement, connector assembly
- 70475 & 71178 ,male, single row, insulation displacement, connector assembly
- 70543, single row, .120" pocket, wire-to-board, shrouded header, vertical
- 70541, single row, .120" pocket, wire-to-board, shrouded header, vertical, split peg
- 70545, single row, .120" pocket, wire-to-board, shrouded header, vertical, tri-peg
- 70553, single row, .120" pocket, wire-to-board, shrouded header, right angle
- 70555, single row, .120" pocket, wire-to-board, shrouded header, right angle, tri-peg
- 70563, single row, .180" pocket, wire-to-board, shrouded header, vertical
- 70565, single row, .180" pocket, wire-to-board, shrouded header, vertical, tri-peg
- 70573, single row, .180" pocket, wire-to-board, shrouded header, right angle
- 70575, single row, .180" pocket, wire-to-board, shrouded header, right angle, tri-peg

REVISE ON PC ONLY		TITLE	PRODUCT SPECIFICATION SINGLE ROW – STACKABLE LINEAR (SL) CONNECTOR SYSTEM			
F	ADD PROCESS TEMPERATURE UDT2002-1016 RSFOX 2/13/02				THIS DOCUMENT CONTAINS INFORMATION THAT IS PROPRIETARY TO MOLEX INC. AND SHOULD NOT BE USED WITHOUT WRITTEN PERMISSION	
	REV					
DOCUMENT NO. PS - 70400		FILE NAME	SHEET 2			
BORDER TEMPLATE: ES-40000-3996 REV. A SHEET 3 95/MAR/10 EC U5-0926 DCBRD03.LWP						



PRODUCT SPECIFICATION



LANGUAGE
ENGLISH

2.2 DIMENSIONS, MATERIALS AND SPECIFICATIONS:

2.2.1 Mating Pin Height

2.2.1.1 Maximum mating pin height: .320" (8.13 mm)

2.2.1.2 Minimum mating pin height: .200" (5.08 mm)

2.2.2 Centerline spacing (pitch): .100" (2.54 mm)

2.2.3 Wire Sizes: #22 - #28 AWG stranded wire, with an insulation diameter of .053" (1.35 mm) max.

2.2.4 Molex cable: 7307, 7767, 8996, 8997, 24226, 24241, 24369 and 24389.

2.2.5 Termination Method:

2.2.5.1 Crimp (70021, 70058)

2.2.5.2 IDT (70400, 70475)

2.2.6 Housings: (70066, 70450, 70107): Black Glass Filled Polyester, UL 94V-0

2.2.7 Terminals: (70021, 70058): Phosphor Bronze

2.2.7 Plating: Gold and tin/Lead

2.2.7.1 Gold: 30 μ-in. min. Gold in select area over Nickel overall with 75 μ-in. Tin/Lead in select area over Nickel overall

or

Gold: 15 μ-in. min. Gold in select area over Nickel overall with 75 μ-in. Tin/Lead in select area over Nickel overall

2.2.7.2 Tin: 150 μ-in. min. Tin/Lead over Nickel overall.

See the appropriate Sales Drawing(s) for additional information on dimensions, materials, platings, and markings.

REVISE ON PC ONLY		TITLE PRODUCT SPECIFICATION SINGLE ROW – STACKABLE LINEAR (SL) CONNECTOR SYSTEM	THIS DOCUMENT CONTAINS INFORMATION THAT IS PROPRIETARY TO MOLEX INC. AND SHOULD NOT BE USED WITHOUT WRITTEN PERMISSION	
F	ADD PROCESS TEMPERATURE UDT2002-1016 RSFOX 2/13/02			
	DESCRIPTION			
DOCUMENT NO. PS - 70400		FILE NAME	SHEET 3	
BORDER TEMPLATE: ES-40000-3996 REV. A SHEET 3 95/MAR/10 EC U5-0926 DCBRD03.LWP				



PRODUCT SPECIFICATION



LANGUAGE
ENGLISH

2.3 SAFETY AGENCY APPROVALS:

UL File Number E29179
 CSA File Number LR19980

3.0 APPLICABLE DOCUMENTS AND SPECIFICATIONS:

All documents referenced shall be of the latest revision. The order of precedence shall be as follows.

- Product Drawings
- This product specification
- Reference documents

3.1 REFERENCE DOCUMENTS:

- EIA 364 Electronic Industries Association, Recommended Standard
- MIL-STD-202: Test methods for electronics and electrical component parts.
- UL-94: Tests for flammability of plastic material

4.0 RATINGS:

4.1 VOLTAGE:

250 V

4.2 CURRENT:

- 1.2 A - 28 AWG
- 1.8 A - 26 AWG
- 3.0 A - 24 AWG
- 3.0 A - 22 AWG

4.2 TEMPERATURE:

Operating: -40 °C to +105 °C
 Processing: See chart on next page.

REVISE ON PC ONLY		TITLE	PRODUCT SPECIFICATION SINGLE ROW – STACKABLE LINEAR (SL) CONNECTOR SYSTEM	
F	ADD PROCESS TEMPERATURE UDT2002-1016 RSFOX 2/13/02			
	REV	DESCRIPTION	FILE NAME	SHEET
DOCUMENT NO. PS - 70400				4
BORDER TEMPLATE: ES-40000-3996 REV. A SHEET 3 95/MAR/10 EC U5-0926 DCBRD03.LWP				



PRODUCT SPECIFICATION



LANGUAGE
ENGLISH



Temperature vs. Time

Series: 70543, 70541, 70545, 70553, 70551, 70555, 70634, 74190, 70563, 70565, 70573, and 70575

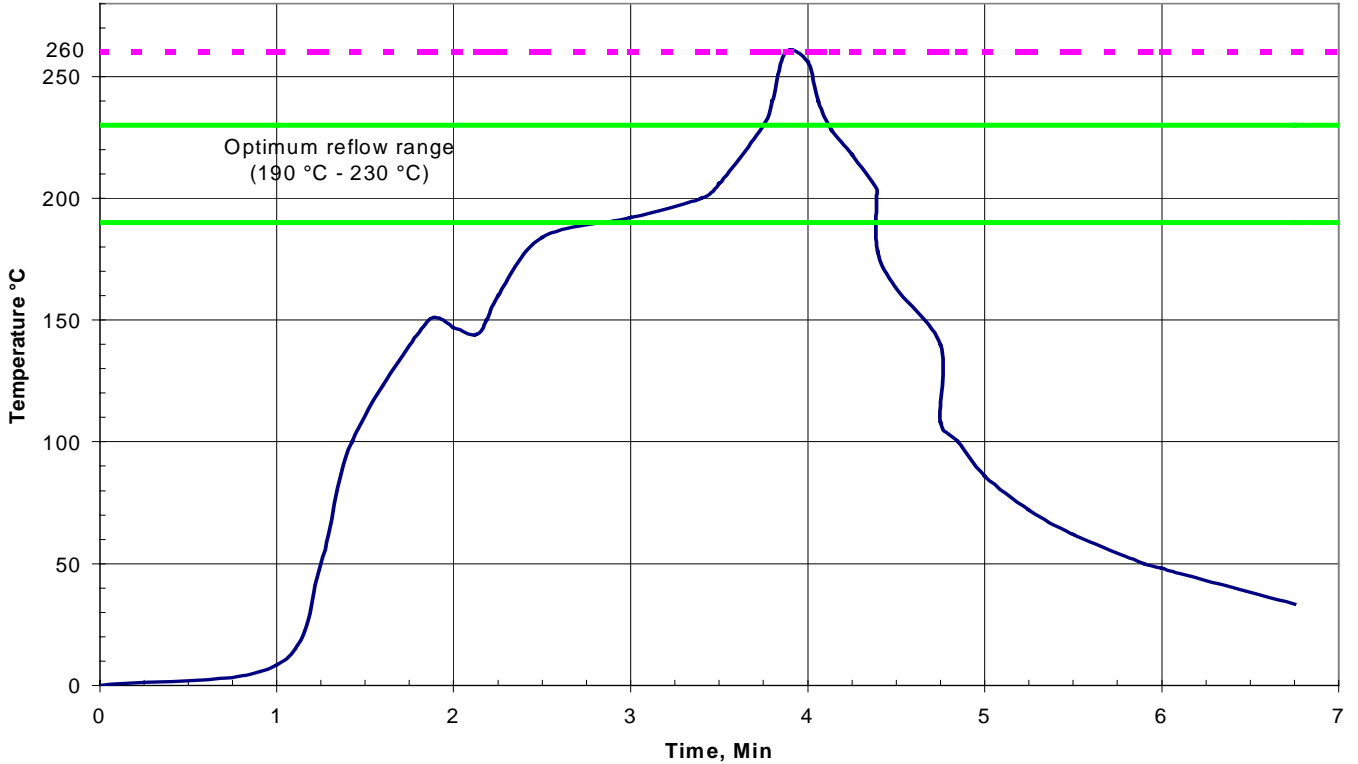

REVISE ON PC ONLY		TITLE PRODUCT SPECIFICATION SINGLE ROW – STACKABLE LINEAR (SL) CONNECTOR SYSTEM
F	ADD PROCESS TEMPERATURE UDT2002-1016 RSFOX 2/13/02	
REV	DESCRIPTION	
DOCUMENT NO. PS - 70400		THIS DOCUMENT CONTAINS INFORMATION THAT IS PROPRIETARY TO MOLEX INC. AND SHOULD NOT BE USED WITHOUT WRITTEN PERMISSION
BORDER TEMPLATE: ES-40000-3996 REV. A SHEET 3 95/MAR/10 EC U5-0926 DCBRD03.LWP		FILE NAME SHEET 5



PRODUCT SPECIFICATION



LANGUAGE

ENGLISH

5.0 PERFORMANCE:

5.1 ELECTRICAL PERFORMANCE:

Item	Test Condition	Requirement
Contact Resistance (Low Level)	Mate Connectors with a maximum voltage of 20mV and a current of 100 mA.	30 milliohm Maximum Initial
Insulation Resistance	Mate Connectors with a voltage of 500 VDC between adjacent terminals and between terminals and ground.	1000 Megohms Minimum
Dielectric Withstanding Voltage	Mate Connectors with a voltage of 1500 VAC for 1 min. between adjacent terminals and between terminals and ground.	No breakdown
Capacitance	Measure between adjacent terminals at 1 MHz. (Loaded: 50 ohms impedance)	Loaded: 2 picofarad max. Unloaded: 0.5 picofarad max.

5.2 MECHANICAL PERFORMANCE:

Item	Test Condition	Requirement
Terminal Insertion and Withdrawal Forces	Insert and withdraw a terminal (male to female) at a rate of 25 ± 6mm (1 ± 1/4 inch) per minute.	70058 - Insertion force shall be 4.45 N (1.0 lb) max. and withdrawal 0.56 N (0.125 lb) min. 71851 - Insertion force shall be 13.34 N (3.0 lb) max. and withdrawal 1.67 N (0.375 lb) min
Terminal Retention Force (in Housing)	Axial pullout force on the terminal in the housing at a rate of 25 ± 6mm (1 ± 1/4 inch) per minute.	Contact : 17.79 N (4.0 lbs.) min.
Durability	Mate connectors up to 25 cycles for tin plating and 50 cycles for gold plating at a maximum rate of 10 cycles per minute prior to defined Environmental Tests.	Contact Resistance : 10 milliohms Maximum Change from Initial

REVISE ON PC ONLY		TITLE	PRODUCT SPECIFICATION SINGLE ROW – STACKABLE LINEAR (SL) CONNECTOR SYSTEM			
F	ADD PROCESS TEMPERATURE UDT2002-1016 RSFOX 2/13/02				THIS DOCUMENT CONTAINS INFORMATION THAT IS PROPRIETARY TO MOLEX INC. AND SHOULD NOT BE USED WITHOUT WRITTEN PERMISSION	
	REV					
DOCUMENT NO. PS - 70400		FILE NAME	SHEET 6			



PRODUCT SPECIFICATION



LANGUAGE
ENGLISH

Item	Test Condition	Requirement
Vibration Mil-Std-1344 Method 2005.1 Condition I	Amplitude: 1.50mm (.060 inch) peak to peak Sweep: 10-55-10 Hz in one minute Duration: 2 hours in each X-Y-Z axis. (Test module shall be per Section 7.0)	Contact Resistance: 10 milliohms Maximum Change from Initial Discontinuity: not greater than one microsecond
Mechanical Shock Mil-Std-1344 Method 2004.1 Condition A	50 g's with three 1/2 sine wave form shocks in each X-Y-Z axis. (Test module shall be per Section 8.2)	Contact Resistance: 10 milliohms Maximum Change from Initial Discontinuity: not greater than one microsecond
Wire Pullout Force (Axial)	Apply an axial pullout force on the wire at a rate of 25 ± 6mm (1 ± 1/4 inch) per minute.	Pullout force - 75% tensile strength of wire, minimum.
Wire Pullout Force (Right Angle)	Apply a right angle pullout force on the wire at a rate of 25 ± 6mm (1 ± 1/4 inch) per minute.	Pullout force - 75% tensile strength of wire, minimum.
Terminal Insertion Force (into Housing)	Apply an axial insertion force on the terminal at a rate of 25 ± 6mm (1 ± 1/4 inch) per minute.	13.34 N (3.0 lbs) maximum insertion force.
Wire Flex	Flex cable 180° for 500 cycles.	Contact resistance: 10 milliohms Maximum Change from Initial. Appearance: No Damage
Normal Force	Apply a perpendicular force at a rate of of 25 ± 6mm (1 ± 1/4 inch) per minute on the contacts in a manner simulating actual use.	0.49 N (50 grams) minimum end of life, for gold plating 0.98 N (100 grams) minimum end of life, for tin plating.

REVISE ON PC ONLY		TITLE PRODUCT SPECIFICATION SINGLE ROW – STACKABLE LINEAR (SL) CONNECTOR SYSTEM
F	ADD PROCESS TEMPERATURE UDT2002-1016 RSFOX 2/13/02	
REV	DESCRIPTION	
DOCUMENT NO. PS - 70400		THIS DOCUMENT CONTAINS INFORMATION THAT IS PROPRIETARY TO MOLEX INC. AND SHOULD NOT BE USED WITHOUT WRITTEN PERMISSION
		FILE NAME
		SHEET 7
BORDER TEMPLATE: ES-40000-3996 REV. A SHEET 3 95/MAR/10 EC U5-0926 DCBRD03.LWP		



PRODUCT SPECIFICATION



LANGUAGE

ENGLISH

5.3 ENVIRONMENTAL PERFORMANCE

Item	Test Condition	Requirement												
Thermal Shock Mil-Std-202F Method 107 E	Mate connectors exposed to 10 cycles of: <table border="1"> <thead> <tr> <th>Temperature °C</th> <th>Duration (Min)</th> </tr> </thead> <tbody> <tr> <td>-40 +0/-3</td> <td>30</td> </tr> <tr> <td>+25 +/-10</td> <td>5 Max</td> </tr> <tr> <td>+105 +3/-0</td> <td>30</td> </tr> <tr> <td>+25 +/-10</td> <td>5 Max</td> </tr> <tr> <td>-40 +0/-3</td> <td>30</td> </tr> </tbody> </table>	Temperature °C	Duration (Min)	-40 +0/-3	30	+25 +/-10	5 Max	+105 +3/-0	30	+25 +/-10	5 Max	-40 +0/-3	30	Appearance: No Damage Contact Resistance: 10 milliohms maximum change from initial
Temperature °C	Duration (Min)													
-40 +0/-3	30													
+25 +/-10	5 Max													
+105 +3/-0	30													
+25 +/-10	5 Max													
-40 +0/-3	30													
Thermal Aging Mil-Std-202F Method 108	Mate connectors; expose to 240 hours at 105 ± 3° C	Appearance: No Damage Contact Resistance: 10 milliohms maximum change from initial												
Humidity (Steady State) Mil-Std-202F Method 103	Mate connectors; expose to a temperature of : 85 ± 2°C with a Relative Humidity of 92 ± 3% for 96 hours. Note: Remove surface moisture and air dry for 1 hour prior to measurements.	Appearance: No Damage Contact Resistance: 10 milliohms maximum change from initial. Dielectric Withstanding Voltage: No Breakdown Insulation Resistance: 1000 Megohms Minimum												
Humidity (Cyclic) Mil-Std-202 Method 105	Mate connectors; expose for 10 cycles at 90-98% relative humidity with a transition time of 2.5 hours between extremes: <table border="1"> <thead> <tr> <th>Temperature °C</th> <th>Duration (Min)</th> </tr> </thead> <tbody> <tr> <td>+25 ± 10</td> <td>5 maximum</td> </tr> <tr> <td>+65 +3/-0</td> <td>15 maximum</td> </tr> </tbody> </table> Note: Remove surface moisture and air dry for one hour prior to measurements.	Temperature °C	Duration (Min)	+25 ± 10	5 maximum	+65 +3/-0	15 maximum	Appearance: No Damage Contact Resistance: 10 milliohms maximum change from initial. Dielectric Withstanding Voltage: No Breakdown Insulation Resistance: 1000 Megohms Minimum						
Temperature °C	Duration (Min)													
+25 ± 10	5 maximum													
+65 +3/-0	15 maximum													

REVISE ON PC ONLY		TITLE	PRODUCT SPECIFICATION SINGLE ROW – STACKABLE LINEAR (SL) CONNECTOR SYSTEM		
F	ADD PROCESS TEMPERATURE UDT2002-1016 RSFOX 2/13/02			THIS DOCUMENT CONTAINS INFORMATION THAT IS PROPRIETARY TO MOLEX INC. AND SHOULD NOT BE USED WITHOUT WRITTEN PERMISSION	
	REV				
DOCUMENT NO. PS - 70400		FILE NAME	SHEET 8		



PRODUCT SPECIFICATION



LANGUAGE

ENGLISH

Item	Test Condition	Requirement
Temperature Rise and Current Cycling	Temperature Rise: Mate the connectors; and measure the temperature rise at the rated current after 96 hours.	Temperature Rise: 30°C above ambient maximum
	Current Cycling: Mate connectors; measure the temperature rise at the rated current after 500 hours (45 minutes ON and 15 minutes OFF per hour).	Temperature Rise: 30°C above ambient maximum
Solderability Molex SMES-152	Steam age 1 hr. Solder time 5 ± 0.5 seconds. Solder temperature: $245 \pm 5^\circ\text{C}$ Non activated flux.	95% of the immersed area must show no voids, pin holes
Flowing Mixed Gas (FMG)	Battelle Class II, 10 ppm Cl_2 , 10 ppm H_2S , 100 ppm NO_2 , $70 \pm 1\%$ R.H., 25 deg. C. 50-60 CFM. 10 days mated and 7 days unmated exposure.	Contact Resistance: 10 milliohms Maximum change from Initial
Resistance to Solder Heats	Solder Time 3 ± 0.5 seconds Solder Temperature: $260 \pm 5^\circ\text{C}$ Immerse leads to a depth of 1.57mm (.062 in.) from connector body.	Appearance: No damage or discoloration of connector materials.

6.0 PACKAGING:

Parts are packaged in trays, tubes or bulk packed, refer to appropriate Sales Drawing for specific information.

7.0 QUALITY ASSURANCE PROVISIONS:

7.1 MATERIAL INSPECTION:

Shall consist of certification supported by verifying data.

REVISE ON PC ONLY		TITLE PRODUCT SPECIFICATION SINGLE ROW – STACKABLE LINEAR (SL) CONNECTOR SYSTEM	THIS DOCUMENT CONTAINS INFORMATION THAT IS PROPRIETARY TO MOLEX INC. AND SHOULD NOT BE USED WITHOUT WRITTEN PERMISSION	
F	ADD PROCESS TEMPERATURE UDT2002-1016 RSFOX 2/13/02			
	DESCRIPTION			
DOCUMENT NO. PS - 70400		FILE NAME	SHEET 9	
BORDER TEMPLATE: ES-40000-3996 REV. A SHEET 3 95/MAR/10 EC U5-0926 DCBRD03.LWP				



PRODUCT SPECIFICATION



LANGUAGE
ENGLISH

7.2 ACCEPTANCE INSPECTION:

Acceptance of ongoing production product shall be determined by inspection according to Molex approved quality plans and required PPM levels for critical characteristics.

7.3 CONFORMANCE TESTING:

Shall be performed on production quality manufactured products. Sample size shall be per 8.1.

7.4 Gages:

Terminal insertion/withdrawal testing should be performed with the gage pin detailed below.

8.0 QUALIFICATION REQUIREMENTS:

8.1 QUALIFICATION TESTING:

1. Samples for testing shall be representative of normal production lots.
2. Sample groups shall consist of a minimum (5) mated pairs of headers and receptacles. 30 minimum data points per group shall be measured. Measurements shall be taken from the middle and ends of the connectors as a minimum.

REVISE ON PC ONLY		TITLE	PRODUCT SPECIFICATION SINGLE ROW – STACKABLE LINEAR (SL) CONNECTOR SYSTEM	
F	ADD PROCESS TEMPERATURE UDT2002-1016 RSFOX 2/13/02			
REV	DESCRIPTION			
DOCUMENT NO. PS - 70400		FILE NAME	SHEET 10	
BORDER TEMPLATE: ES-40000-3996 REV. A SHEET 3 95/MAR/10 EC U5-0926 DCBRD03.LWP				



PRODUCT SPECIFICATION



LANGUAGE
ENGLISH

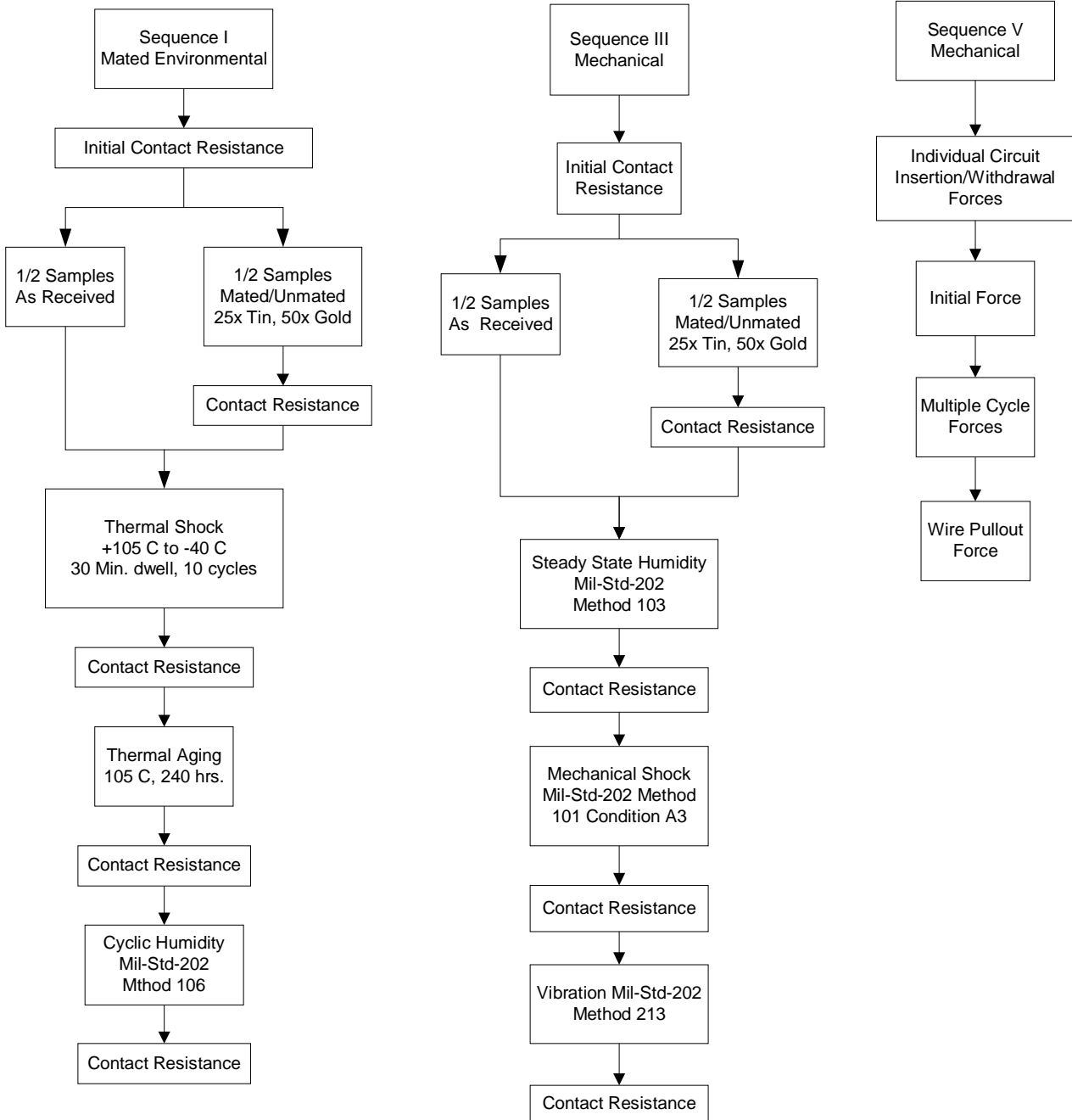

REVISE ON PC ONLY		TITLE PRODUCT SPECIFICATION SINGLE ROW – STACKABLE LINEAR (SL) CONNECTOR SYSTEM
F	ADD PROCESS TEMPERATURE UDT2002-1016 RSFOX 2/13/02	
REV	DESCRIPTION	
DOCUMENT NO. PS - 70400		THIS DOCUMENT CONTAINS INFORMATION THAT IS PROPRIETARY TO MOLEX INC. AND SHOULD NOT BE USED WITHOUT WRITTEN PERMISSION
BORDER TEMPLATE: ES-40000-3996 REV. A SHEET 3 95/MAR/10 EC U5-0926 DCBRD03.LWP		FILE NAME SHEET 11



PRODUCT SPECIFICATION



LANGUAGE

ENGLISH

9.0 TEST SUMMARY:

9.1 SEQUENCE I - MATED ENVIRONMENTAL:

TEST CONDITION	TREATMENT	REQUIREMENT	UNITS	MEAN	MINIMUM	MAXIMUM
Contact Resistance	Initial	30 max.	milliohms	14.47	13.77	15.08
	After Durability	10 max. Change from initial	Δ -milliohms	.09	-0.82	1.40
	After Shock (Thermal)	10 max. Change from initial	Δ -milliohms	.02	-1.15	1.32
	After Thermal Aging	10 max. Change from initial	Δ -milliohms	.00	-1.06	1.18
	After Humidity (Cyclic)	10 max. Change from initial	Δ -milliohms	.25	-1.00	1.78

9.2 SEQUENCE III - MECHANICAL:

TEST CONDITION	TREATMENT	REQUIREMENT	UNITS	MEAN	MINIMUM	MAXIMUM
Contact Resistance	Initial	30 max.	milliohms	8.6	8.0	9.4
	After Humidity (Steady State)	10 max. Change from initial	Δ -milliohms	8.6	8.0	9.6
	After Shock (Mechanical)	10 max. Change from initial	Δ -milliohms	8.7	8.1	9.9
	After Vibration	10 max. Change from initial	Δ -milliohms	8.7	8.1	9.4

REVISE ON PC ONLY		TITLE	PRODUCT SPECIFICATION SINGLE ROW – STACKABLE LINEAR (SL) CONNECTOR SYSTEM					
F	ADD PROCESS TEMPERATURE UDT2002-1016 RSFOX 2/13/02					THIS DOCUMENT CONTAINS INFORMATION THAT IS PROPRIETARY TO MOLEX INC. AND SHOULD NOT BE USED WITHOUT WRITTEN PERMISSION		
	REV							
DOCUMENT NO. PS - 70400		FILE NAME	SHEET 12					



PRODUCT SPECIFICATION



LANGUAGE
ENGLISH

9.3 ENVIRONMENTAL PERFORMANCE:

TEST CONDITION	TREATMENT	REQUIREMENT	UNITS	MAXIMUM
Temperature Rise and Current Cycling (+30°C)	22 AWG	**** Minimum	Amps	3
	24 AWG	**** Minimum	Amps	3
	26 AWG	**** Minimum	Amps	1.8
	28 AWG	**** Minimum	Amps	1.2
	30 AWG	**** Minimum	Amps	0.70
	32 AWG	**** Minimum	Amps	0.45
	34 AWG	**** Minimum	Amps	0.32
	36 AWG	**** Minimum	Amps	0.21

9.4 SEQUENCE V - MECHANICAL:

70058 - MATING FORCE SEQUENCE 5.3						
TEST CONDITION	TREATMENT	PLATING	UNITS	MEAN	MINIMUM	MAXIMUM
Insertion Force	Initial	Tin	LB/(N)	0.73/(3.24)	0.62/(2.74)	0.82/(3.63)
		Gold	LB/(N)	0.39/(1.75)	0.28/(1.25)	0.59/(2.62)
	After 25 Cycles	Tin	LB/(N)	0.75/(3.32)	0.64/(2.83)	0.89/(3.94)
	After 50 Cycles	Gold	LB/(N)	0.44/(1.96)	0.27/(1.19)	0.55/(2.44)
Withdrawal Force	Initial	Tin	LB/(N)	0.97/4.31	0.79/(3.52)	1.05/(4.65)
		Gold	LB/(N)	0.29/(1.28)	0.20/(0.89)	0.44/(1.97)
	After 25 Cycles	Tin	LB/(N)	0.77/(3.43)	0.68/(3.04)	0.90/(4.02)
	After 50 Cycles	Gold	LB/(N)	0.38/(1.69)	0.29/(1.29)	0.56/(2.50)

71851 - MATING FORCE SEQUENCE 5.3						
TEST CONDITION	TREATMENT	PLATING	UNITS	MEAN	MINIMUM	MAXIMUM
Insertion Force	Initial	Tin	LB/N	2.39/10.62	2.24/9.96	2.53/11.25
		Gold	LB/N	0.99/4.39	0.91/4.05	1.05/4.67
	After 25 Cycles	Tin	LB/N	2.18/9.71	1.60/7.12	2.82/12.54
	After 50 Cycles	Gold	LB/N	1.01/4.48	0.86/3.83	1.17/5.20
Withdrawal Force	Initial	Tin	LB/N	2.68/11.92	2.28/10.14	3.18/14.15
		Gold	LB/N	0.69/3.07	0.62/2.76	0.77/3.43
	After 25 Cycles	Tin	LB/N	2.70/12.02	1.79/7.96	4.23/18.82
	After 50 Cycles	Gold	LB/N	1.07/4.76	0.84/3.74	1.25/5.56

REVISE ON PC ONLY		TITLE PRODUCT SPECIFICATION SINGLE ROW – STACKABLE LINEAR (SL) CONNECTOR SYSTEM	THIS DOCUMENT CONTAINS INFORMATION THAT IS PROPRIETARY TO MOLEX INC. AND SHOULD NOT BE USED WITHOUT WRITTEN PERMISSION	
F	ADD PROCESS TEMPERATURE UDT2002-1016 RSFOX 2/13/02			
	DESCRIPTION			
DOCUMENT NO. PS - 70400		FILE NAME	SHEET 13	



PRODUCT SPECIFICATION



LANGUAGE
ENGLISH

TEST CONDITION	TREATMENT	PLATING	UNITS	MEAN	MINIMUM	MAXIMUM
Wire Pullout Force (Axial)	22 AWG with strain relief	**** Minimum	N/LB	65.3/14.67	56.2/12.63	72.4/16.28
	22 AWG w/o strain relief	**** Minimum	N/LB	48.0/10.78	39.2/8.81	54.5/12.24
	24 AWG	**** Minimum	N/LB	37.0/8.32	28.5/6.40	44.9/10.10
	26 AWG	**** Minimum	N/LB			
	28 AWG	**** Minimum	N/LB			
	30 AWG	**** Minimum	N/LB			
	32 AWG	**** Minimum	N/LB			
	34 AWG	**** Minimum	N/LB			
36 AWG	**** Minimum	N/LB				

9.5 MISCELLANEOUS:

TEST CONDITION	TREATMENT	REQUIREMENT	UNITS	MEAN	MINIMUM	MAXIMUM
Terminal Retention Force (in Housing)	Initial	**** Minimum	N/LB	37.94/8.53	23.04/5.18	55.74/12.53
Insulation Resistance	Initial	1000 Min.	Megaohms	Passed		
	After Shock (Thermal)	1000 Min.	Megaohms	Passed		
	After Thermal Aging	1000 Min.	Megaohms	Passed		
	After Humidity (Steady State)	1000 Min.	Megaohms	Passed		
	After Humidity (Cyclic)	1000 Min.	Megaohms	Passed		

REVISE ON PC ONLY		TITLE	PRODUCT SPECIFICATION SINGLE ROW – STACKABLE LINEAR (SL) CONNECTOR SYSTEM			
F	ADD PROCESS TEMPERATURE UDT2002-1016 RSFOX 2/13/02				THIS DOCUMENT CONTAINS INFORMATION THAT IS PROPRIETARY TO MOLEX INC. AND SHOULD NOT BE USED WITHOUT WRITTEN PERMISSION	
	REV					
DOCUMENT NO. PS - 70400		FILE NAME	SHEET 14			

NOTES:

1. MATERIAL: G.F. POLYESTER, 94V-0, COLOR: BLACK
2. HOUSING MAY BE USED WITH TERMINAL NUMBERS 70058 AND 71851.
3. REFER TO CHART FOR AVAILABLE CIRCUIT SIZES.
4. HOUSINGS TO BE USED WITH (0.64)/.025 SQUARE OR ROUND PINS.
5. HOUSINGS ARE STACKABLE END-TO-END ON (2.54)/.100 CENTERS.
6. REFER TO MOLEX PRODUCT SPECIFICATIONS PS-70058, PS-71851, AND MOLEX APPLICATION SPECIFICATION SD-70400.
7. PARTS MAY OR MAY NOT BE SUPPLIED WITH EXTERIOR CORE-OUT CONFIGURATION. REFER TO MOLEX DRAWING NUMBER SD-70066-**** FOR OPTIONAL HOUSING DETAILS.
8. DIMENSIONS ARE SHOWN FOR REFERENCE ONLY.
9. PACKAGE PER PK-70066-100.

CKT. SIZE	EDP. NO.	ENG. NO.	A ± (0.10) -.004	B MAX.
2	50-57-9402	70066-0176	(2.54) .100	(5.05) .199
3	50-57-9403	70066-0177	(5.08) .200	(7.59) .299
4	50-57-9404	70066-0178	(7.62) .300	(10.13) .399
5	50-57-9405	70066-0179	(10.16) .400	(12.67) .499
6	50-57-9406	70066-0180	(12.70) .500	(15.21) .599
7	50-57-9407	70066-0181	(15.24) .600	(17.75) .699
8	50-57-9408	70066-0182	(17.78) .700	(20.29) .799
9	50-57-9409	70066-0183	(20.32) .800	(22.83) .899
10	50-57-9410	70066-0184	(22.86) .900	(25.37) .999
11	50-57-9411	70066-0185	(25.40) 1.000	(27.91) 1.099
12	50-57-9412	70066-0186	(27.94) 1.100	(30.45) 1.199
13	50-57-9413	70066-0187	(30.48) 1.200	(32.99) 1.299
14	50-57-9414	70066-0188	(33.02) 1.300	(35.53) 1.399
15	50-57-9415	70066-0189	(35.56) 1.400	(38.07) 1.499
16	50-57-9416	70066-0190	(38.10) 1.500	(40.61) 1.599
17	50-57-9417	70066-0191	(40.64) 1.600	(43.15) 1.699
18	50-57-9418	70066-0192	(43.18) 1.700	(45.69) 1.799
19	50-57-9419	70066-0193	(45.72) 1.800	(48.23) 1.899
20	50-57-9420	70066-0194	(48.26) 1.900	(50.77) 1.999
21	50-57-9421	70066-0195	(50.80) 2.000	(53.31) 2.099
22	50-57-9422	70066-0196	(53.34) 2.100	(55.85) 2.199
23	50-57-9423	70066-0197	(55.88) 2.200	(58.39) 2.299
24	50-57-9424	70066-0198	(58.42) 2.300	(60.93) 2.399
25	50-57-9425	70066-0199	(60.96) 2.400	(63.47) 2.499

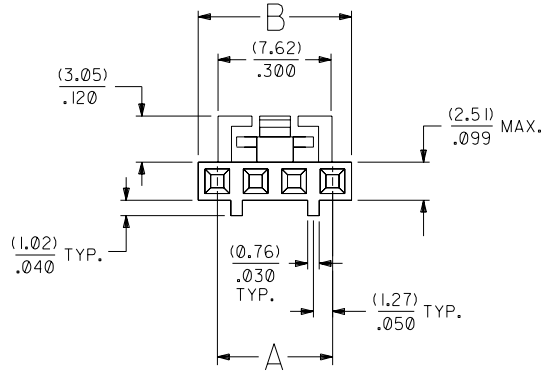

CIRCUIT NO. 1 IDENTIFICATION

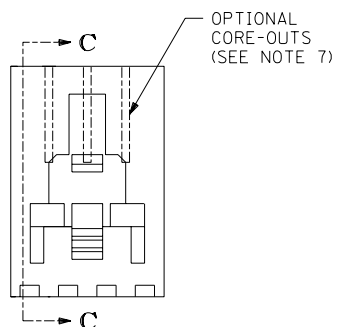
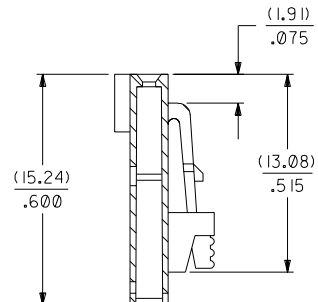
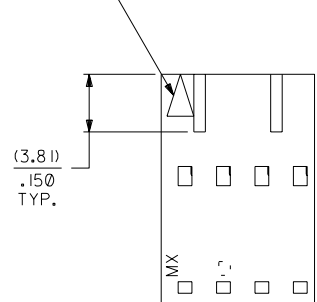

SECTION C-C

OPTION "G"

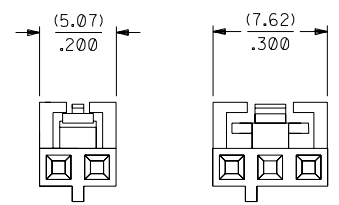

LATCH AND POLARIZATION RIB LOCATION

4 THROUGH 25 CIRCUIT HOUSINGS ARE AS SHOWN IN MAIN BODY OF DRAWING

DIMENSIONS SHOWN (METRIC) INCH UNLESS OTHERWISE SPECIFIED TOLERANCES: ANGULAR ± 1/2°		MFG. SH. REV.	
3 PLACE ± .007 2 PLACE ± ± 0.18 1 PLACE ± ±		REVISIONS ONLY ON CAD SYSTEM	
DRAG WHERE APPLICABLE MUST REMAIN WITHIN DIMENSIONS		TITLE HOUSING, CONNECTOR (2.54)/.100 GRID STACKABLE SINGLE ROW	
DRWG. BY: RS APP'D. BY: RL		PART NO. SD-70066-0176-0199	
CHK'D. BY: WZ SCALE: 4 : 1		SHEET NO. 1 OF 1 DATE 03/28/86	
LTR. REVISIONS		THIS DRAWING CONTAINS INFORMATION THAT IS PROPRIETARY TO MOLEX INC. AND SHOULD NOT BE USED WITHOUT WRITTEN PERMISSION.	