

Distributed by:

**JAMECO**<sup>®</sup>  
ELECTRONICS

**www.Jameco.com ♦ 1-800-831-4242**

The content and copyrights of the attached  
material are the property of its owner.

Jameco Part Number 1932416

## 0.50mm (.020") Pitch FFC/FPC Connector

### 52559

#### Vertical, SMT, ZIF

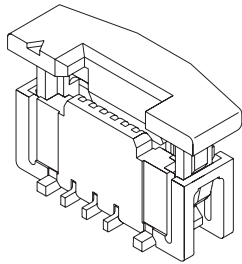

#### Features and Benefits

- Sizes 6 to 42 circuits
- For 0.30mm thick FFC/FPC
- Metal solder tabs provide PCB hold-down and strain relief for SMT tails
- For XX70 packaging, component is centered relative to the sprocket hole; for XX72, actuator is centered relative to the sprocket hole

#### Reference Information

Packaging: Embossed tape  
Designed In: Millimeters

#### Electrical

Voltage: 50V  
Current: 0.5A  
Contact Resistance: 20 milliohms max.  
Dielectric Withstanding Voltage: 250V AC/1 min.  
Insulation Resistance: 50 Megohms min.

#### Physical

Housing: 4/6 nylon, UL 94V-0  
Actuator: PPS, UL 94V-0  
Contact: Phosphor Bronze  
Plating: Tin Bismuth over Nickel  
Solder Tabs: Phosphor Bronze, Tin over Nickel plating  
Operating Temperature: -20 to +85°C

Circuits	Order No.	Carrier Tape Width	Lead-free
6	<a href="#">52559-0672</a>	24.00 (.945)	Yes
8	<a href="#">52559-0870</a>		
9	<a href="#">52559-0972</a>		
10	<a href="#">52559-1072</a>		
12	<a href="#">52559-1272</a>		
13	<a href="#">52559-1370</a>		
14	<a href="#">52559-1472</a>		
15	<a href="#">52559-1572</a>		
16	<a href="#">52559-1672</a>		
17	<a href="#">52559-1772</a>		
18	<a href="#">52559-1870</a>		
20	<a href="#">52559-2072</a>		

Circuits	Order No.	Carrier Tape Width	Lead-free
21	<a href="#">52559-2172</a>	24.00 (.945)	
22	<a href="#">52559-2270</a>		
24	<a href="#">52559-2472</a>		
25	<a href="#">52559-2570</a>		
26	<a href="#">52559-2672</a>	32.00 (1.260)	Yes
28	<a href="#">52559-2872</a>		
30	<a href="#">52559-3072</a>		
32	<a href="#">52559-3272</a>		
33	<a href="#">52559-3370</a>		
36	<a href="#">52559-3672</a>		
40	<a href="#">52559-4072</a>	44.00 (1.732)	
42	<a href="#">52559-4272</a>		

Note: Contact Molex for cable specification dimensions

## 0.50mm (.020") Pitch Easy-On™ FFC/FPC Connector

### 51374

#### Vertical, SMT, ZIF

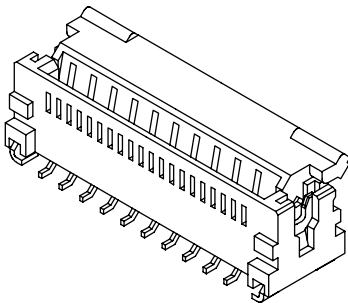

#### Features and Benefits

- For 0.30mm (.012") thick FFC/FPC
- Actuator rotates to allow for easy cable insertion from top or side
- Metal solder tabs provide PCB hold-down and strain relief for SMT tails

#### Reference Information

Product Specification: PS-51374-022  
Packaging: Embossed tape  
Designed In: Millimeters

#### Electrical

Voltage: 50V  
Current: 0.4A  
Contact Resistance: 40 milliohms max.  
Dielectric Withstanding Voltage: 250V AC/1 min.  
Insulation Resistance: 50 Megohms min.

#### Physical

Housing: Glass-filled LCP, UL 94V-0  
Actuator: Glass-filled PPS, UL 94V-0  
Contact: Copper Alloy  
Solder Tabs: Copper Alloy  
Plating: Tin/Bismuth over Nickel  
Operating Temperature: -25 to +85°C

Circuits	Order No.	Carrier Tape Width	Lead-free
10	<a href="#">51374-1073</a>	24.00 (.945)	Yes
13	<a href="#">51374-1373</a>		
15	<a href="#">51374-1573</a>		
20	<a href="#">51374-2073</a>		
24	<a href="#">51374-2473</a>	32.00 (1.260)	
26	<a href="#">51374-2673</a>		

Circuits	Order No.	Carrier Tape Width	Lead-free
30	<a href="#">51374-3073</a>	32.00 (1.260)	Yes
33	<a href="#">51374-3373</a>	44.00 (1.732)	
40	<a href="#">51374-4073</a>		
45	<a href="#">51374-4573</a>		
50	<a href="#">51374-5073</a>		
60	<a href="#">51374-6073</a>	56.00 (2.205)	



PRODUCT SPECIFICATION



LANGUAGE

JAPANESE  
ENGLISH

【1. 適用範囲 SCOPE】

本仕様書は、 \_\_\_\_\_ 殿 に納入する  
0.5mmピッチ FPC用コネクタ について規定する。

This specification covers the 0.5mm PITCH FPC CONNECTOR series.

【2. 製品名称及び型番 PRODUCT NAME AND PART NUMBER】

製品名称 Product Name	製品型番 Parts Number
ハウジング アッセンブリ Housing Assembly (STRAIGHT TYPE)	(無鉛) LEAD FREE 52559-**19
52559-**19 エンボス梱包品 Embossed Tape Package for 52559-**19	(無鉛) LEAD FREE 52559-**70 52559-**72

\*\* : 図面参照 Refer to the drawing.

【3. 定格 RATINGS】

項目 Item	規格 Standard
最大許容電圧 Rated Voltage (MAXIMUM)	50 V
許容電流 Rated Current	0.5 A
使用温度範囲 Ambient Temperature Range.	-40°C ~ +85°C*1 *2

\*1 : 通電による温度上昇分も含む。

Including terminal temperature rise.

\*2 : 適合FPCも本使用温度範囲を満足すること。

FPC must be meet temperature range specified in this standard.

REV.	D																					
SHEET	1~9																					
REVISE ON PC ONLY										TITLE:												
D										0.5mm PITCH FPC CONN.												
変更 REVISED J2007-0178 '06/07/20 Y.AOYAGI										-LEAD FREE- 製品仕様書												
THIS DOCUMENT CONTAINS INFORMATION THAT IS PROPRIETARY TO MOLEX INC. AND SHOULD NOT BE USED WITHOUT WRITTEN PERMISSION																						
REV.		DESCRIPTION																				
DESIGN CONTROL J					STATUS					WRITTEN BY: M.NINOMIYA			CHECKED BY: K.TOJO			APPROVED BY: M.SASAO			DATE: YR/MO/DAY 2004/02/10			
DOCUMENT NUMBER PS-52559-012															FILE NAME PS52559012.doc				SHEET 1 OF 9			



PRODUCT SPECIFICATION



LANGUAGE

JAPANESE  
ENGLISH

【4. 性能 PERFORMANCE】

4-1. 電気的性能 Electrical Performance

項目 Item	条件 Condition	規格 Standard
4-1-1 接触抵抗 Contact Resistance	適合FPCを装着し、開放電圧 20mV以下、短絡電流 10mAにて測定する。 (JIS C5402 5.4) Mate applicable FPC, measure by dry circuit, 20mV MAXIMUM, 10mA. (JIS C5402 5.4)	20 milliohm MAXIMUM
4-1-2 絶縁抵抗 Insulation Resistance	適合FPCを装着し、隣接するターミナル間及びターミナル、アース間に、DC 500Vを印加し測定する。 (JIS C5402 5.2/MIL-STD-202 試験法 302) Mate applicable FPC, apply 500V DC between adjacent terminal or ground. (JIS C5402 5.2/MIL-STD-202 Method 302)	50 Megohm MINIMUM
4-1-3 耐電圧 Dielectric Strength	適合FPCを装着し、隣接するターミナル間及びターミナル、アース間に、AC 250V (実効値) を 1分間印加する。 (JIS C5402 5.1/MIL-STD-202 試験法 301) Mate applicable FPC, apply 250V AC (rms) for 1 minute between adjacent terminal or ground. (JIS C5402 5.1/MIL-STD-202 Method 301)	異状なきこと No Breakdown

4-2. 機械的性能 Mechanical Performance

項目 Item	条件 Condition	規格 Standard
4-2-1 アクチュエータ挿抜力 Actuator and Withdrawal Force	適合FPCを嵌合させ、アクチュエータを毎分 25±3mmの速さで挿入、抜去を行う。 Mate applicable FPC and Insert and withdraw actuator at the speed rate of 25±3mm/minute.	第6項参照 Refer to paragraph 6
4-2-2 FPC保持力 FPC Retention Force	アクチュエータ挿入状態にて、毎分 25±3mmの速さでFPCを引き抜く。 Insert the actuator, pull the FPC at the speed rate of 25±3mm/minute.	第7項参照 Refer to paragraph 7
4-2-3 端子保持力 Terminal / Housing Retention Force	端子を毎分 25±3mmの速さで引張る。 Apply axial pull out force at the speed rate of 25±3mm/minute on the terminal assembled in the housing.	3.0 N {0.30 kgf} MINIMUM
4-2-4 金具保持力 Fitting nail/ Housing Retention Force	金具を毎分 25±3mmの速さで引張る。 Apply axial pull out force at the speed rate of 25±3mm/minute on the fitting nail assembled in the housing.	3.0 N {0.30 kgf} MINIMUM

REVISE ON PC ONLY		TITLE: 0.5mm PITCH FPC CONN. -LEAD FREE- 製品仕様書
<b>D</b>	SEE SHEET 1 OF 9	
REV.	DESCRIPTION	THIS DOCUMENT CONTAINS INFORMATION THAT IS PROPRIETARY TO MOLEX INC. AND SHOULD NOT BE USED WITHOUT WRITTEN PERMISSION

DOCUMENT NUMBER <b>PS-52559-012</b>	FILE NAME PS52559012.doc	SHEET 2 OF 9
--	-----------------------------	-----------------



PRODUCT SPECIFICATION



LANGUAGE

JAPANESE  
ENGLISH

4-3. その他 Environmental Performance and Others

項目 Item		条件 Condition	規格 Standard	
4-3-1	アクチュエータ 繰返し動作 Repeated Actuator Insertion / Withdrawal	無通電状態にて、1分間に10回以下の速さで挿入、抜去を 20回繰り返す。 Insert and withdraw actuator up to 20 cycles at the speed rate of less than 10 cycle/minute.	接触抵抗 Contact Resistance	40 milliohm MAXIMUM
4-3-2	温度上昇 Temperature Rise	適合FPCを嵌合させ、最大許容電流を通電し、コネクタの温度上昇分を測定する。 (UL 498) Carrying rated current load. (UL 498)	温度上昇 Temperature Rise	30 °C MAXIMUM
4-3-3	耐振動性 Vibration	DC 1mA通電状態にて、嵌合軸を含む互いに垂直な 3方向に掃引割合 10~55~10Hz/分、全振幅 1.5mmの振動を各 2時間加える。 (MIL-STD-202 試験法 201) Amplitude : 1.5mm P-P Sweep time : 10~55~10Hz in 1 minute Duration : 2 hours in each X, Y, Z axes (MIL-STD-202 Method 201)	外観 Appearance	異常なきこと No Damage
			接触抵抗 Contact Resistance	40 milliohm MAXIMUM
			瞬断 Discontinuity	1.0 microsecond MAXIMUM
4-3-4	耐衝撃性 Shock	DC 1mA通電状態にて、嵌合軸を含む互いに垂直な 6方向に 490m/s <sup>2</sup> {50G}の衝撃を各 3回加える。 (JIS C0041/MIL-STD-202 試験法 213) 490m/s <sup>2</sup> {50G}, 3 strokes in each X,Y,Z axes. (JIS C0041/MIL-STD-202 Method 213)	外観 Appearance	異常なきこと No Damage
			接触抵抗 Contact Resistance	40 milliohm MAXIMUM
			瞬断 Discontinuity	1.0 microsecond MAXIMUM
4-3-5	耐熱性 Heat Resistance	適合FPCを嵌合させ、85±2°Cの雰囲気中に96時間放置後取り出し、1~2時間室温に放置する。 (JIS C0021/MIL-STD-202 試験法 108) 85±2°C, 96 hours (JIS C0021/MIL-STD-202 Method 108)	外観 Appearance	異常なきこと No Damage
			接触抵抗 Contact Resistance	40 milliohm MAXIMUM
4-3-6	耐寒性 Cold Resistance	適合FPCを嵌合させ、-40±2°Cの雰囲気中に96時間放置後取り出し、1~2時間室温に放置する。 (JIS C0020) -40±2°C, 96 hours (JIS C0020)	外観 Appearance	異常なきこと No Damage
			接触抵抗 Contact Resistance	40 milliohm MAXIMUM

REVISE ON PC ONLY

D

SEE SHEET 1 OF 9

TITLE:

0.5mm PITCH FPC CONN.

-LEAD FREE-

製品仕様書

REV.

DESCRIPTION

THIS DOCUMENT CONTAINS INFORMATION THAT IS PROPRIETARY TO MOLEX INC. AND SHOULD NOT BE USED WITHOUT WRITTEN PERMISSION

DOCUMENT NUMBER

PS-52559-012

FILE NAME

PS52559012.doc

SHEET

3 OF 9

EN-37-1(019)



PRODUCT SPECIFICATION



LANGUAGE

JAPANESE  
ENGLISH

項目 Item		条件 Condition	規格 Standard	
4-3-7	耐湿性 Humidity	適合FPCを嵌合させ、60±2℃、 相対湿度 90~95%の雰囲気中に 96時間 放置後取り出し、1~2時間室温に放置する。 (JIS C0022/MIL-STD-202 試験法103)  Temperature : 60±2℃ Relative Humidity : 90~95% Duration : 96 hours (JIS C0022/MIL-STD-202 Method 103)	外観 Appearance	異常なきこと No Damage
			接触抵抗 Contact Resistance	40 milliohm MAXIMUM
			耐電圧 Dielectric Strength	4-1-3項満足のこと Must meet 4-1-3
			絶縁抵抗 Insulation Resistance	20 Megohm MINIMUM
4-3-8	温度サイクル Temperature Cycling	適合FPCを嵌合させ、-55℃に 30分、 +85℃に 30分、これを 1サイクルとし、 5サイクル繰り返す。但し、温度移行時間は 1時間以内とする。試験後、1~2時間室温に 放置する。 (JIS C0025)  5 cycles of : a) -55℃ 30 minutes b) +85℃ 30 minutes (JIS C0025)	外観 Appearance	異常なきこと No Damage
			接触抵抗 Contact Resistance	40 milliohm MAXIMUM
4-3-9	塩水噴霧 Salt Spray	適合FPCを嵌合させ、35±2℃にて 5±1%重量比の塩水を 48±4時間噴霧し、 試験後、常温で水洗いした後、室温で 乾燥させる。 (JIS C5028/MIL-STD-202 試験法101)  48±4hours exposure to a salt spray from the 5±1% solution at 35±2℃. (JIS C5028/MIL-STD-202 Method 101)	外観 Appearance	異常なきこと No Damage
			接触抵抗 Contact Resistance	40 milliohm MAXIMUM
4-3-10	亜硫酸ガス SO <sub>2</sub> Gas	適合FPCを嵌合させ、40±2℃にて 50±5ppmの亜硫酸ガス中に 24時間放置する。  24hours exposure to 50±5ppm. SO <sub>2</sub> gas at 40±2℃.	外観 Appearance	異常なきこと No Damage
			接触抵抗 Contact Resistance	40 milliohm MAXIMUM

REVISE ON PC ONLY		TITLE:  0.5mm PITCH FPC CONN.  -LEAD FREE-      製品仕様書
<b>D</b>	SEE SHEET 1 OF 9	
REV.	DESCRIPTION	THIS DOCUMENT CONTAINS INFORMATION THAT IS PROPRIETARY TO MOLEX INC. AND SHOULD NOT BE USED WITHOUT WRITTEN PERMISSION

DOCUMENT NUMBER <b>PS-52559-012</b>	FILE NAME PS52559012.doc	SHEET 4 OF 9
EN-37-1(019)		



PRODUCT SPECIFICATION



LANGUAGE

JAPANESE  
ENGLISH

項 目 Item		条 件 Condition	規 格 Standard	
4-3-11	耐アンモニア性 NH <sub>3</sub> Gas	適合FPCを嵌合させ、濃度 28%のアンモニア水を入れた容器中に 40分間放置する。 (1Lに対して 25mLの割合)	外 観 Appearance	異状なきこと No Damage
		40 minutes exposure to NH <sub>3</sub> gas evaporating from 28% Ammonia solution.	接触抵抗 Contact Resistance	40 milliohm MAXIMUM
4-3-12	半田付け性 Solderability	端子先端より0.2mm、金具先端より0.2mmの位置まで245±5°Cの半田に 3±0.5秒浸す。 Dip terminal and fitting nail (held at 245±5°C) up to 0.2mm from the tip for 3±0.5 seconds.	濡れ性 Solder Wetting	浸漬面積の 90%以上 90% of immersed area must show no voids, pin holes
4-3-13	半田耐熱性 Resistance to Soldering Heat	(リフロー時) 第8項の条件を2回繰り返す。  (When reflowing) Repeat paragraph 8, condition two times.	外 観 Appearance	端子ガタ、割れ等 異状なきこと No Damage
		(手半田時) 端子先端より0.2mm、金具先端まで0.2mmの位置まで、370~400°Cの半田ゴテにて最大5秒加熱後。  Dip terminal and fitting nail (held at 370~400°C) up to 0.2mm from the tip for 5 seconds MAXIMUM.		

( ) : 参考規格 Reference Standard  
{ } : 参考単位 Reference Unit

【5. 外観形状、寸法及び材質 PRODUCT SHAPE, DIMENSIONS AND MATERIALS】

図面参照 Refer to the drawing.

REVISE ON PC ONLY		TITLE:	
<b>D</b>	SEE SHEET 1 OF 9	0.5mm PITCH FPC CONN.	
		-LEAD FREE- 製品仕様書	
REV.	DESCRIPTION	THIS DOCUMENT CONTAINS INFORMATION THAT IS PROPRIETARY TO MOLEX INC. AND SHOULD NOT BE USED WITHOUT WRITTEN PERMISSION	
DOCUMENT NUMBER <b>PS-52559-012</b>		FILE NAME PS52559012.doc	SHEET 5 OF 9



PRODUCT SPECIFICATION



LANGUAGE

JAPANESE  
ENGLISH

【6. アクチュエータ挿抜力 ACTUATOR INSERTION AND WITHDRAWAL FORCE】

極数 No. of CKT.	単位 UNIT	挿入力 (最大値)			抜去力 (最大値)		
		INSERTION FORCE (MAXIMUM)			WITHDRAWAL FORCE (MAXIMUM)		
		初回 1st	6回目 6th	20回目 20th	初回 1st	6回目 6th	20回目 20th
6	N {kgf}	30.3 {3.1}	28.4 {2.9}	28.4 {2.9}	39.2 {4.0}	35.2 {3.6}	35.2 {3.6}
8	N {kgf}	32.3 {3.3}	30.3 {3.1}	30.3 {3.1}	41.1 {4.2}	37.2 {3.8}	37.2 {3.8}
9	N {kgf}	33.3 {3.4}	31.3 {3.2}	31.3 {3.2}	42.1 {4.3}	38.2 {3.9}	38.2 {3.9}
10	N {kgf}	34.3 {3.5}	32.3 {3.3}	32.3 {3.3}	43.1 {4.4}	39.2 {4.0}	39.2 {4.0}
12	N {kgf}	36.2 {3.7}	34.3 {3.5}	34.3 {3.5}	45.0 {4.6}	41.1 {4.2}	41.1 {4.2}
13	N {kgf}	37.2 {3.8}	35.2 {3.6}	35.2 {3.6}	46.1 {4.7}	42.2 {4.3}	42.2 {4.3}
14	N {kgf}	38.2 {3.9}	36.2 {3.7}	36.2 {3.7}	47.0 {4.8}	43.1 {4.4}	43.1 {4.4}
15	N {kgf}	39.2 {4.0}	37.2 {3.8}	37.2 {3.8}	48.0 {4.9}	44.1 {4.5}	44.1 {4.5}
16	N {kgf}	40.1 {4.1}	38.2 {3.9}	38.2 {3.9}	49.0 {5.0}	45.0 {4.6}	45.0 {4.6}
17	N {kgf}	41.1 {4.2}	39.2 {4.0}	39.2 {4.0}	49.9 {5.1}	46.0 {4.7}	46.0 {4.7}
18	N {kgf}	42.1 {4.3}	40.1 {4.1}	40.1 {4.1}	50.9 {5.2}	47.0 {4.8}	47.0 {4.8}
20	N {kgf}	44.1 {4.5}	42.1 {4.3}	42.1 {4.3}	52.9 {5.4}	49.0 {5.0}	49.0 {5.0}
21	N {kgf}	45.0 {4.6}	43.1 {4.4}	43.1 {4.4}	53.9 {5.5}	49.9 {5.1}	49.9 {5.1}
22	N {kgf}	46.0 {4.7}	44.1 {4.5}	44.1 {4.5}	54.8 {5.6}	50.9 {5.2}	50.9 {5.2}
23	N {kgf}	47.0 {4.8}	45.0 {4.6}	45.0 {4.6}	55.8 {5.7}	51.9 {5.3}	51.9 {5.3}
24	N {kgf}	48.0 {4.9}	46.0 {4.7}	46.0 {4.7}	56.8 {5.8}	52.9 {5.4}	52.9 {5.4}
25	N {kgf}	49.0 {5.0}	47.0 {4.8}	47.0 {4.8}	57.8 {5.9}	53.9 {5.5}	53.9 {5.5}
26	N {kgf}	49.9 {5.1}	48.0 {4.9}	48.0 {4.9}	58.8 {6.0}	54.8 {5.6}	54.8 {5.6}
27	N {kgf}	50.9 {5.2}	49.0 {5.0}	49.0 {5.0}	59.7 {6.1}	55.8 {5.7}	55.8 {5.7}
28	N {kgf}	51.9 {5.3}	49.9 {5.1}	49.9 {5.1}	60.7 {6.2}	56.8 {5.8}	56.8 {5.8}

REVISE ON PC ONLY		TITLE:	
<b>D</b>	SEE SHEET 1 OF 9	0.5mm PITCH FPC CONN.	
		-LEAD FREE- 製品仕様書	
REV.	DESCRIPTION	THIS DOCUMENT CONTAINS INFORMATION THAT IS PROPRIETARY TO MOLEX INC. AND SHOULD NOT BE USED WITHOUT WRITTEN PERMISSION	
DOCUMENT NUMBER <b>PS-52559-012</b>		FILE NAME PS52559012.doc	SHEET 6 OF 9
EN-37-1(019)			





PRODUCT SPECIFICATION



LANGUAGE

JAPANESE  
ENGLISH

極数 No. of CKT.	単位 UNIT	挿入力 (最大値) INSERTION FORCE (MAXIMUM)			抜去力 (最大値) WITHDRAWAL FORCE (MAXIMUM)		
		初回 1st	6回目 6th	20回目 20th	初回 1st	6回目 6th	20回目 20th
		30	N {kgf}	53.9 {5.5}	51.9 {5.3}	51.9 {5.3}	62.7 {6.4}
32	N {kgf}	55.8 {5.7}	53.9 {5.5}	53.9 {5.5}	64.6 {6.6}	60.7 {6.2}	60.7 {6.2}
33	N {kgf}	56.8 {5.8}	54.8 {5.6}	54.8 {5.6}	64.6 {6.7}	61.7 {6.3}	61.7 {6.3}
36	N {kgf}	59.7 {6.1}	57.8 {5.9}	57.8 {5.9}	68.6 {7.0}	64.6 {6.6}	64.6 {6.6}
40	N {kgf}	63.7 {6.5}	61.7 {6.3}	61.7 {6.3}	72.5 {7.4}	68.6 {7.0}	68.6 {7.0}

【7. FPC保持力 FPC RETENTION FORCE】

極数 No. of CKT.	単位 UNIT	抜去力 (最小値) WITHDRAWAL FORCE (MINIMUM)		極数 No. of CKT.	単位 UNIT	抜去力 (最小値) WITHDRAWAL FORCE (MINIMUM)	
		初回 1st	20回目 20th			初回 1st	20回目 20th
6	N {kgf}	1.7 {0.17}	1.0 {0.10}	22	N {kgf}	8.2 {0.83}	6.7 {0.68}
8	N {kgf}	2.5 {0.25}	1.7 {0.17}	23	N {kgf}	8.5 {0.87}	7.0 {0.71}
9	N {kgf}	2.9 {0.29}	2.1 {0.21}	24	N {kgf}	8.9 {0.91}	7.3 {0.74}
10	N {kgf}	3.3 {0.33}	2.4 {0.24}	25	N {kgf}	9.4 {0.95}	7.7 {0.78}
12	N {kgf}	4.2 {0.42}	3.2 {0.32}	26	N {kgf}	9.7 {0.99}	8.0 {0.82}
13	N {kgf}	4.6 {0.46}	3.5 {0.35}	27	N {kgf}	10.1 {1.03}	8.4 {0.85}
14	N {kgf}	4.9 {0.50}	3.9 {0.39}	28	N {kgf}	10.5 {1.07}	8.7 {0.89}
15	N {kgf}	5.3 {0.54}	4.2 {0.42}	30	N {kgf}	11.3 {1.15}	9.4 {0.96}
16	N {kgf}	5.7 {0.58}	4.6 {0.46}	32	N {kgf}	12.1 {1.23}	10.1 {1.03}
17	N {kgf}	6.1 {0.62}	4.8 {0.49}	33	N {kgf}	12.5 {12.7}	10.4 {1.06}
18	N {kgf}	6.5 {0.66}	5.2 {0.53}	36	N {kgf}	13.8 {1.40}	11.5 {1.17}
20	N {kgf}	7.3 {0.74}	5.9 {0.60}	40	N {kgf}	15.3 {1.56}	12.9 {1.32}
21	N {kgf}	7.7 {0.78}	6.3 {0.64}				

REVISE ON PC ONLY		TITLE:	
<b>D</b>	SEE SHEET 1 OF 9	0.5mm PITCH FPC CONN.	
	REV.	DESCRIPTION	-LEAD FREE- 製品仕様書
		THIS DOCUMENT CONTAINS INFORMATION THAT IS PROPRIETARY TO MOLEX INC. AND SHOULD NOT BE USED WITHOUT WRITTEN PERMISSION	
DOCUMENT NUMBER <b>PS-52559-012</b>		FILE NAME PS52559012.doc	SHEET 7 OF 9
EN-37-1(019)			



【8. 赤外線リフロー条件 INFRARED REFLOW CONDITION】

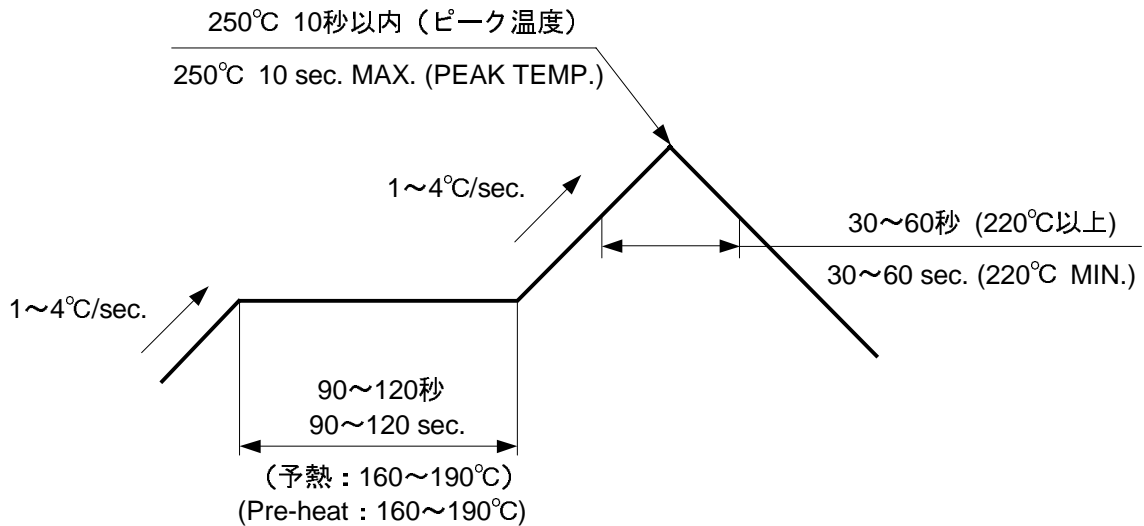

仕様半田組成 : Sn-3Ag-0.5Cu  
リフロー回前 : 2回

注記 ; 本リフロー条件に関しては、リフロー装置及び基板などにより条件が異なりますので、事前にリフロー評価の確認をお願い致します。

NOTE ; Please check the reflow soldering condition by your own devices beforehand. Because the condition changes by the soldering devices, P.C.Boards, and so on.

REVISE ON PC ONLY		TITLE:	
<b>D</b>	SEE SHEET 1 OF 9	0.5mm PITCH FPC CONN. -LEAD FREE- 製品仕様書	
REV.	DESCRIPTION	THIS DOCUMENT CONTAINS INFORMATION THAT IS PROPRIETARY TO MOLEX INC. AND SHOULD NOT BE USED WITHOUT WRITTEN PERMISSION	
DOCUMENT NUMBER <b>PS-52559-012</b>		FILE NAME PS52559012.doc	SHEET 8 OF 9
EN-37-1(019)			



**PRODUCT SPECIFICATION**



LANGUAGE

JAPANESE  
ENGLISH

REV.	REV. RECORD	DATE	EC NO.	WRITTN:	CH'K:
A	RELEASED	'04/01/07	J2004-1815	M.NINOMIYA	K.TOJO
B	REVISED	'04/02/10	J2004-2369	E.SUZUKI	K.TOJO
C	REVISED	'04/07/27	J2005-0304	N.AIDA	K.TOJO
D	REVISED	'06/07/20	J2007-0178	Y.AOYAGI	K.TOYOTA

REVISE ON PC ONLY		TITLE: 0.5mm PITCH FPC CONN. -LEAD FREE- 製品仕様書
<b>D</b>	SEE SHEET 1 OF 9	
REV.	DESCRIPTION	THIS DOCUMENT CONTAINS INFORMATION THAT IS PROPRIETARY TO MOLEX INC. AND SHOULD NOT BE USED WITHOUT WRITTEN PERMISSION

DOCUMENT NUMBER <b>PS-52559-012</b>	FILE NAME PS52559012.doc	SHEET 9 OF 9
--	-----------------------------	-----------------

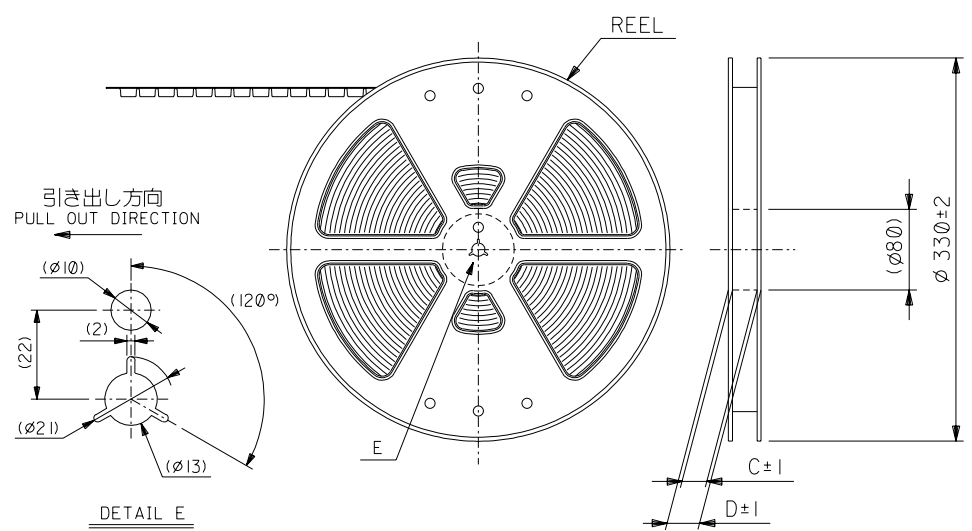

注記 NOTES

- 製品番号 52559-\*\*-19 の梱包状態はアクチュエータがロックした状態とする。  
詳細寸法については図面 SD-52559-027 を参照下さい。  
IN THE PACKAGE,ACTUATOR OF PART NO.52559-\*\*-19 SHOULD BE LOCKED RE DETAILED DIMENSIONS,SEE SD-52559-027
- 梱包数量：1000個/リール  
NUMBER OF CONNECTORS:1000PCS/REEL
- リードテープ長さ LEAD TAPE LENGTH

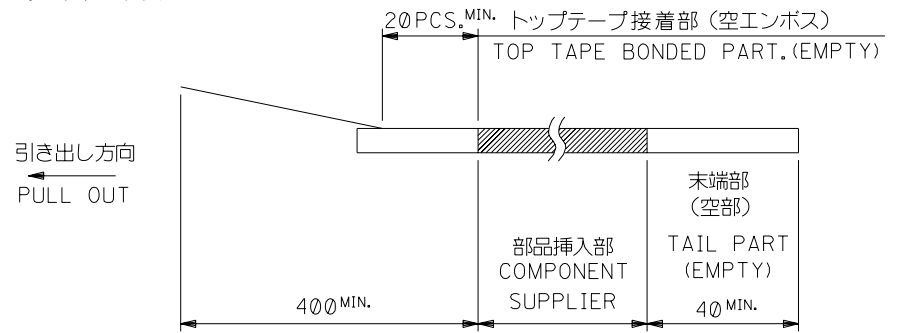

- トップテープの剥離強度：(剥離方向は下図参照)  
0.1~1.3N {10gf~130gf} 尚、本規格値は、出荷時に適用。  
(但し、輸送時に剥離が発生しない事。)

PEELING OFF FORCE OF TOP TAPE  
0.1~1.3N{10gf~130gf}(PEELING DIRECTION AS SHOWN IN FOLLOWING FIG.)  
THIS REQUIREMENT SHOULD BE APPLIED AT SHIPMENT  
PEEL OFF SHOULD NOT BE ALLOWED,  
DURING TRANSPORTATION

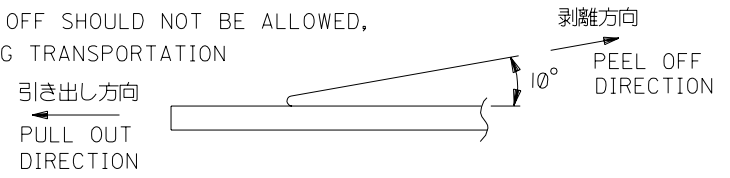

- 材料  
キャリアテープ：ポリプロピレン (PP)  
トップテープ：PET, PE, PEF  
リール：ポリスチレン (PS) <リサイクル材を含む>

MATERIAL CARRIER TAPE:POLYPROPYLENE  
TOP TAPE:PET,PE,PEF  
REEL:POLYSTYREN(PS)  
<RECYCLE MATERIAL CONTAINED>

- 本製品は 52559-\*\*-92の鉛フリー品である。  
THIS PRODUCT IS LEAD FREE OF 52559-\*\*-92

DO NOT SCALE DRAWING

164NO. DRAWN: CHK: APPR:  163NO. DRAWN: CHK: APPR:  162NO. DRAWN: CHK: APPR:	REVISED 161NO. J2004-2769 DRAWN: H.SHIMABUKURO CHK: K.TOJO APPR: H. Saeb	RELEASED 160NO. J2004-1818 DRAWN: H.SHIMABUKURO CHK: K.TOJO APPR: H. Saeb	MATERIAL 材料 注記参照 SEE NOTES	GENERAL TOLERANCES: (UNLESS SPECIFIED) 一般公差 10 UNDER 未満 ±0.2 10 OVER 以上 30 UNDER 未満 ±0.25 30 OVER 以上 ±0.3 ANGLE 角度 ±3°	SCALE 1:1 DESIGN UNITS <input checked="" type="checkbox"/> mm <input type="checkbox"/> INCH APPROVED BY & DATE H. Saeb '04/01/07	DIMENSIONS: <input type="checkbox"/> mm <input type="checkbox"/> INCH <input checked="" type="checkbox"/> mm ONLY SHT 1 OF 4 REV B CAD ONLY	TITLE: 0.5 FPC Conn. Assy ZIF. For SMT,Embstp pkg -LEAD FREE- MOLEX INCORPORATED	MATERIAL NO. 52559-**-72 DRAWING NO. SD-52559-028 SHEET NO. 1 OF 4

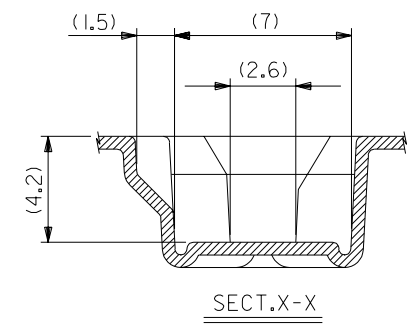
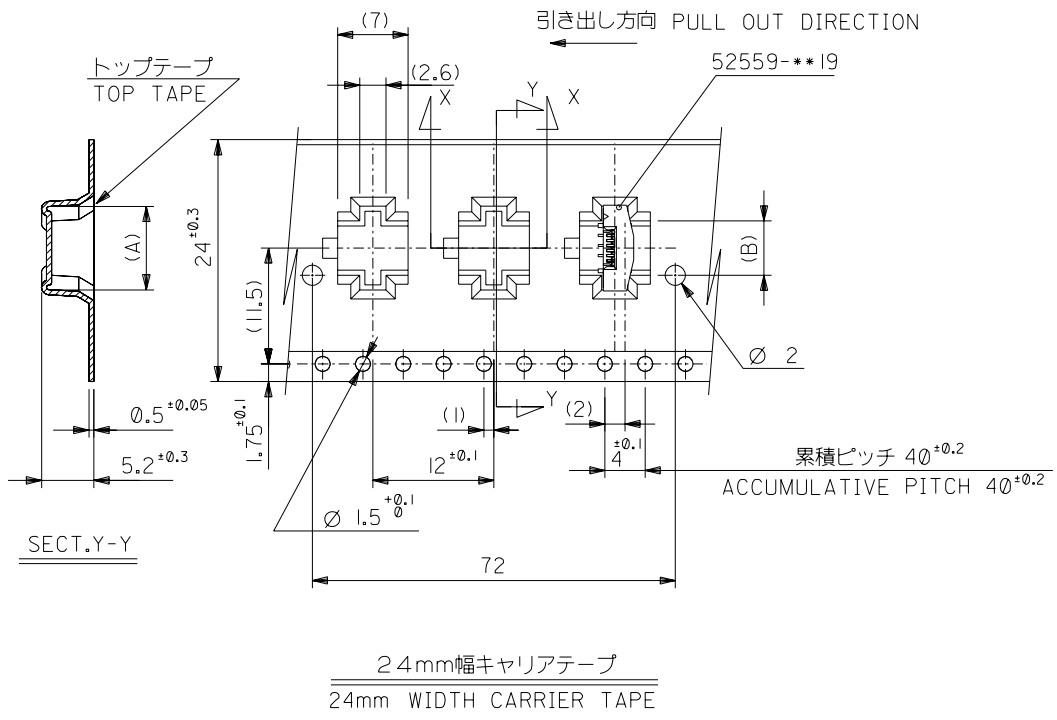

24	29.4	25.4	14.4	17.3	52559-2472	24		
			13.9	16.8	52559-2372	23		
			12.9	15.8	52559-2172	21		
			12.4	15.3	52559-2072	20		
			10.9	13.8	52559-1772	17		
			10.4	13.3	52559-1672	16		
			9.9	12.8	52559-1572	15		
			9.4	12.3	52559-1472	14		
			8.4	11.3	52559-1272	12		
			7.4	10.3	52559-1072	10		
6.9	9.8	52559-0972	9					
5.4	8.3	52559-0672	6					
キャリアテープ幅 CARRIER TAPE WIDTH			D	C	(B)	(A)	MATERIAL NO.	CIRCUIT NO.

264NO. DRWN: CH'K: APPR:	263NO. DRWN: CH'K: APPR:	262NO. DRWN: CH'K: APPR:	<b>REVISED</b> 261NO. J2004-2769 DRWN: H. SHIMABUKURO CH'K: K. TOJO APPR: H. Saito	<b>RELEASED</b> 260NO. J2004-1818 DRWN: H. SHIMABUKURO CH'K: K. TOJO APPR: H. Saito	MATERIAL 材料 注記参照 SEE NOTES	FINISH 仕上げ	WIRE RANGE 適用層線範囲	INS. RANGE 被覆外径
A								

GENERAL TOLERANCES: (UNLESS SPECIFIED) 一般公差	10 UNDER 未満	±0.2
10 OVER 以上	30 UNDER 未満	±0.25
30 OVER 以上		±0.3
ANGLE 角度		±3°

SCALE 縮尺 1:1	DESIGN UNITS 設計単位 <input checked="" type="checkbox"/> mm <input type="checkbox"/> INCH	DIMENSIONS: 寸法 <input type="checkbox"/> mm <input type="checkbox"/> INCH <input checked="" type="checkbox"/> mm ONLY	SHT 枚数 2	REV 回数 4
DRAWN BY & DATE H. SIMABUKURO '04/01/07	CHECKED BY & DATE T. TOJO '04/01/07	APPROVED BY & DATE H. Saito '04/01/07	TITLE: 0.5 FPC Conn. Assy ZIF. For SMT.Embstp pkg -LEAD FREE-	
CAD FILENAME SD-52559-028.S01	MATERIAL NO. 52559-**-72	DRAWING NO. SD-52559-028	SHEET NO. 2 OF 4	

MOLEX INCORPORATED		THIS DRAWING CONTAINS INFORMATION THAT IS PROPRIETARY TO MOLEX INCORPORATED AND SHOULD NOT BE USED WITHOUT WRITTEN PERMISSION.		SIZE B
--------------------	--	--	--	-----------

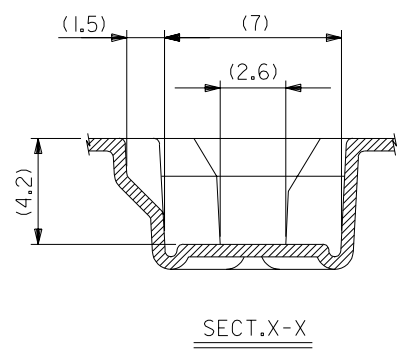
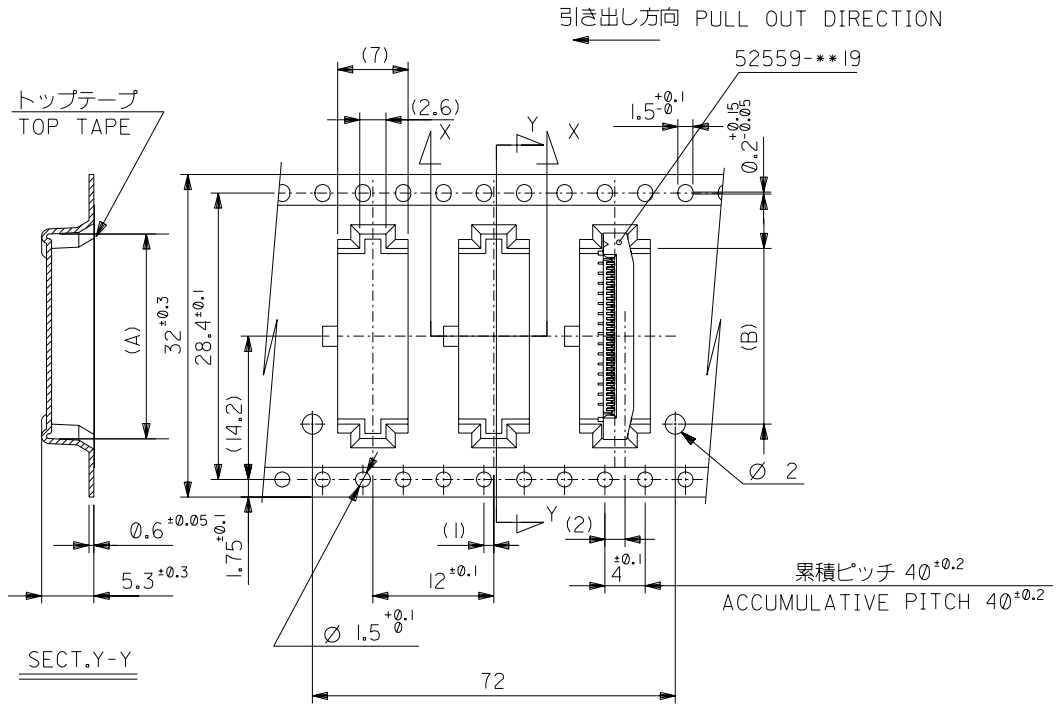

32mm幅キャリアテープ  
32mm WIDTH CARRIER TAPE

32	37.4	33.4	18.4	21.3	52559-3272	32
			17.4	20.3	52559-3072	30
			16.4	19.3	52559-2872	28
			15.9	18.8	52559-2772	27
			15.4	18.3	52559-2672	26
キャリアテープ幅 CARRIER TAPE WIDTH	D	C	(A)	MATERIAL NO.		CIRCUIT NO.

DO NOT SCALE DRAWING

63NO. DRAWN: CH'K: APPR: 63NO. DRAWN: CH'K: APPR: 62NO. DRAWN: CH'K: APPR:	REVISED 61NO. J2004-2769 DRAWN: H.SHIMABUKURO CH'K: K.TOJO APPR: H. Saito	RELEASED 60NO. J2004-1818 DRAWN: H.SHIMABUKURO CH'K: K.TOJO APPR: H. Saito	MATERIAL 材料 注記参照 SEE NOTES	GENERAL TOLERANCES: (UNLESS SPECIFIED) 一般公差	SCALE 1:1	DESIGN UNITS mm	DIMENSIONS: mm	SHT 3 OF 4	REV 0
				FINISH 仕上げ 10 UNDER 未満 30 UNDER 未満 10 OVER 以上 30 OVER 以上	WIRE RANGE 適用層線範囲 10 UNDER 未満 30 UNDER 未満 10 OVER 以上 30 OVER 以上	INS. RANGE 被覆外径 10 UNDER 未満 30 UNDER 未満 10 OVER 以上 30 OVER 以上	TITLE: 0.5 FPC Conn. Assy ZIF. For SMT, Embstp pkg -LEAD FREE-	MOLEX INCORPORATED	CAD FILENAME SD-52559-028.S03

DWG. NO. SD-52559-028

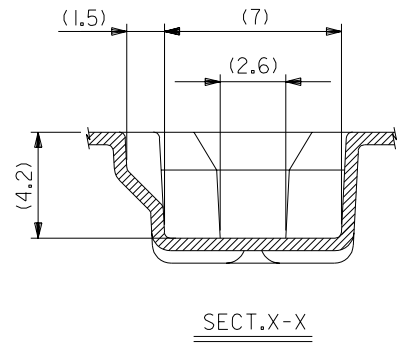
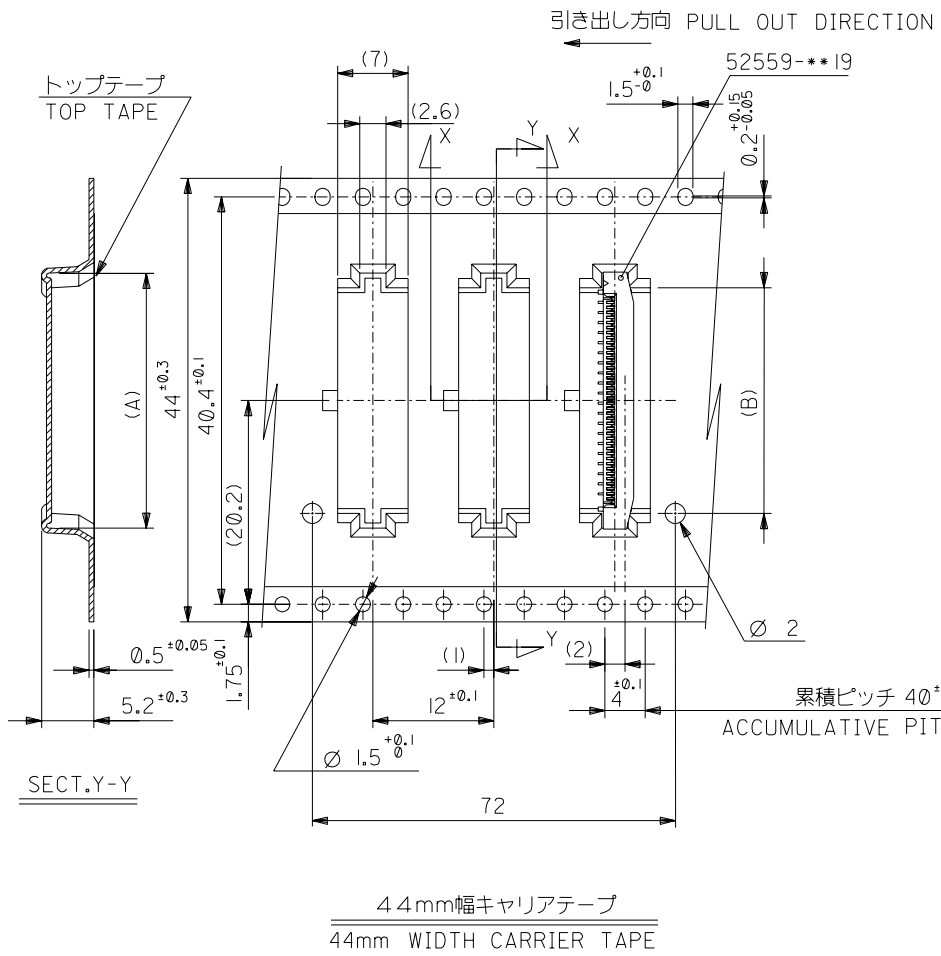

44	49.4	45.4	22.4	25.3	52559-4072	40
キャリアテープ幅 CARRIER TAPE WIDTH	D	C	(A)	(A)	52559-3672	36
					MATERIAL NO.	CIRCUIT NO.

DO NOT SCALE DRAWING

64NO. DRWN: CH'K: APPR: 63NO. DRWN: CH'K: APPR: 62NO. DRWN: CH'K: APPR:	REVISED 61NO. J2004-2769 DRWN: H. SHIMABUKURO CH'K: K. TOJO APPR: H. Saito RELEASED 60NO. J2004-1818 DRWN: H. SHIMABUKURO CH'K: K. TOJO APPR: H. Saito	MATERIAL 材料 注記参照 SEE NOTES FINISH 仕上げ WIRE RANGE 適用層線範囲 INS. RANGE 被覆外径
--	---	--

GENERAL TOLERANCES: (UNLESS SPECIFIED) 一般公差	SCALE	DESIGN UNITS	<input type="checkbox"/> 30° <input checked="" type="checkbox"/> 45° <input type="checkbox"/> 60° <input type="checkbox"/> 90° <input type="checkbox"/> 120° <input type="checkbox"/> 150° <input type="checkbox"/> 180° <input type="checkbox"/> 270° <input type="checkbox"/> 360°	DIMENSIONS: <input type="checkbox"/> mm <input type="checkbox"/> INCH <input checked="" type="checkbox"/> mm ONLY <input type="checkbox"/> INCH ONLY	SHT	REV
10 UNDER 未満	±0.2	mm	DRAWN BY & DATE H. SHIMABUKURO '04/01/07 CHECKED BY & DATE K. TOJO '04/01/07 APPROVED BY & DATE H. Saito '04/01/07	TITLE: 0.5 FPC Conn. Assy ZIF. For SMT.Embstp pkg -LEAD FREE-		
10 OVER 30 UNDER 未満	±0.25	mm				
30 OVER 以上	±0.3	mm				
ANGLE 角度	±3°	mm				

CAD FILENAME SD-52559-028.S04	MATERIAL NO. 52559-***72	DRAWING NO. SD-52559-028	SHEET NO. 4 OF 4
THIS DRAWING CONTAINS INFORMATION THAT IS PROPRIETARY TO MOLEX INCORPORATED AND SHOULD NOT BE USED WITHOUT WRITTEN PERMISSION.			SIZE B

DWG. NO. SD-52559-045

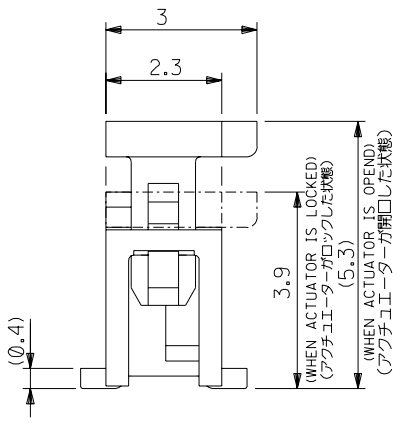
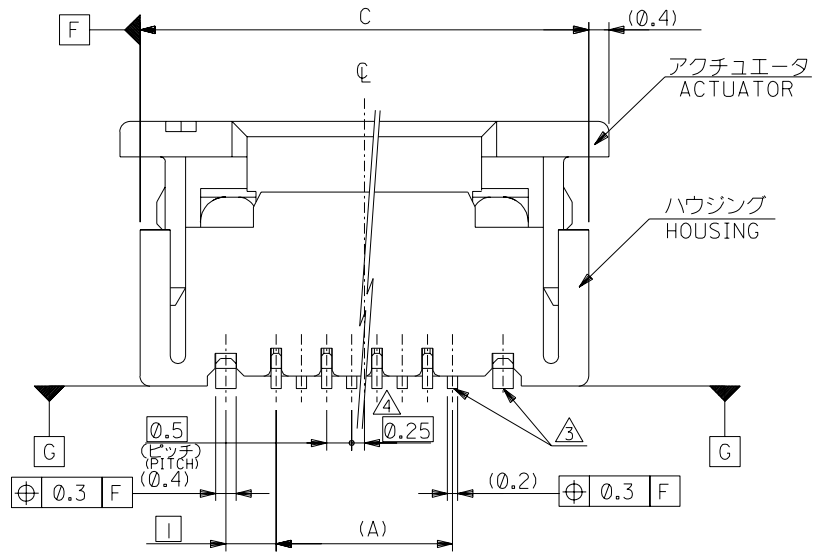
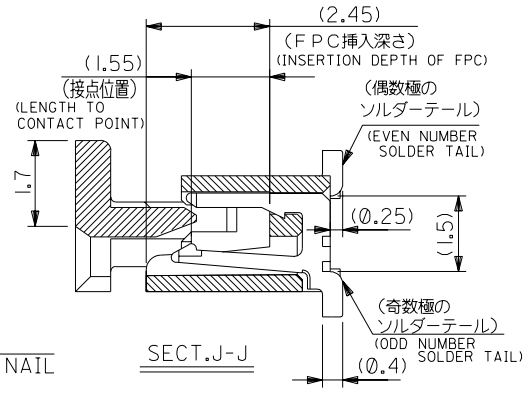
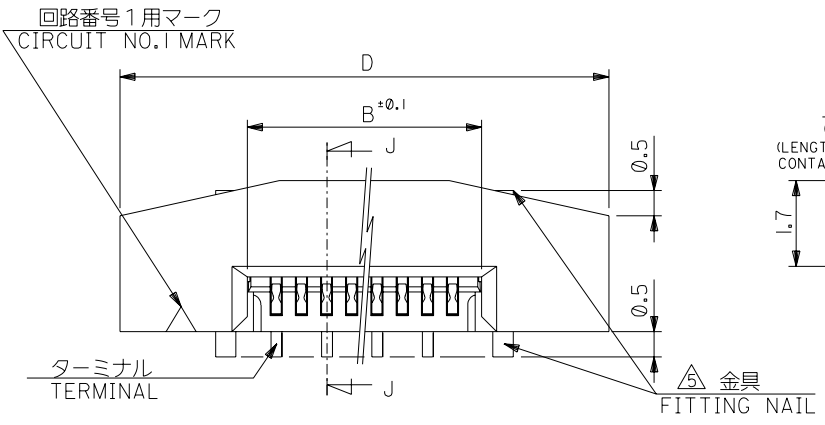

注記 NOTES

- 使用材料: MATERIAL  
 ハウジング :46NYLON UL94V-0  
 アクチュエータ :PPS UL94V-0  
 ターミナル :リン青銅 (t=0.2) PHOS-BRO  
 :錫ビスマスメッキ 1.0マイクロメートル以上 TIN-BISMUTH 1.0 MICROMETER MINIMUM  
 :ニッケル下地 1.0マイクロメートル以上 NICKEL(UNDER PLATING) 1.0 MICROMETER MINIMUM  
 金具 :リン青銅 (t=0.4) PHOS-BRO  
 FITTING NAIL :錫メッキ 1.0マイクロメートル以上 TIN 1.0 MICROMETER MINIMUM  
 :ニッケル下地 1.0マイクロメートル以上 NICKEL(UNDER PLATING) 1.0 MICROMETER MINIMUM
- エンボステープ梱包時は、アクチュエータがロックした状態とする。  
 IN THE PACKAGE,ACTUATOR OF PART NO.52559-\*\*19 SHOULD BE LOCKED.  
 △ソルダータール半田付け面のズレ量、及び金具半田付け面のズレ量は、基準面 G に対し上方向 0.05 MAX. , 下方向 0.15 MAX. とする。  
 MISALIGNMENT OF SOLDER TAILS AND FITTING NAILS FROM G UPPER DIRECTION:0.05 MAX. , LOWER DIRECTION:0.15 MAX.
- 偶数極に適用。  
 APPLY FOR EVEN CIRCUIT.
- パターンはくり止め用金具。  
 FITTING NAIL FOR PREVENTION OF PEELING OF P.C.B. PATTERN.
- R0.3は、FPCの導体部にかからないこと。  
 R0.3 MUST NOT BE OVERLAPPED TO PATTERN OF FPC.
- 本製品は 52559-\*\*17 の鉛フリー品である。  
 THIS PRODUCT IS LEAD FREE OF 52559-\*\*17

DO NOT SCALE DRAWING

64NO. DRWN: CH'K: APPR: 63NO. DRWN: CH'K: APPR: 62NO. DRWN: CH'K: APPR:	REVISED 61NO. J2004-3551 DRWN:H.KAWABATA 04/04/05 CH'K: K.TOJO 04/04/05 APPR: H. Sasaki 04/04/05	RELEASED 60NO. J2004-1818 DRWN:H.SHIMABUKURO 04/01/07 CH'K: K.TOJO 04/01/07 APPR: H. Sasaki 04/01/07
MATERIAL 材料 FINISH 仕上げ WIRE RANGE 適用 規格 範囲 INS. RANGE 被覆 外径	注記参照 SEE NOTES	DESCRIPTION

GENERAL TOLERANCES: (UNLESS SPECIFIED) 一般公差	SCALE 1:1 DESIGN UNITS 一般公差 <input checked="" type="checkbox"/> mm <input type="checkbox"/> INCH	20° 2ND ANGLE PROJECTION
10 UNDER 未満 10 OVER 以上 30 UNDER 未満 30 OVER 以上	±0.2 ±0.25 ±0.3	TITLE: 0.5 FPC Conn. Assy ZIF. -LEAD FREE-
DRAWN BY & DATE H.SHIMABUKURO 04/01/07 CHECKED BY & DATE K.TOJO 04/01/07 APPROVED BY & DATE H. Sasaki 04/01/07	CAD FILENAME SD-52559-045.S01	MATERIAL NO. SEE CHART DRAWING NO. SD-52559-045 SHEET NO. 1 OF 2

MODEL NO. 52559-**19 DIMENSIONS: <input type="checkbox"/> mm <input type="checkbox"/> INCH <input checked="" type="checkbox"/> mm ONLY	SHT 1 REV B OTHERWISE ON CAD ONLY	MOLEX INCORPORATED
THIS DRAWING CONTAINS INFORMATION THAT IS PROPRIETARY TO MOLEX INCORPORATED AND SHOULD NOT BE USED WITHOUT WRITTEN PERMISSION.		



DWG. NO. SD-52559-045

F

D

V

C

B

DO NOT SCALE DRAWING

8 7 6 5 4 3 2 1

F

E

D

C

B

FPCについて：  
 打抜き方向は導体側から補強板側を推奨致します。  
 補強フィルム材質はポリイミドを推奨致します。  
 接着剤は熱硬化接着剤を推奨致します。

ABOUT FPC :  
 RECOMMENDED PUNCHER DIRECTION : FROM CONDUCTOR SIDE TO STIFFENER BOARD SIDE.  
 RECOMMENDED MATERIAL :  
 STIFFENER FILM : POLYIMIDE  
 BONDING AGENT : THERMOSETTING BONDING AGENT

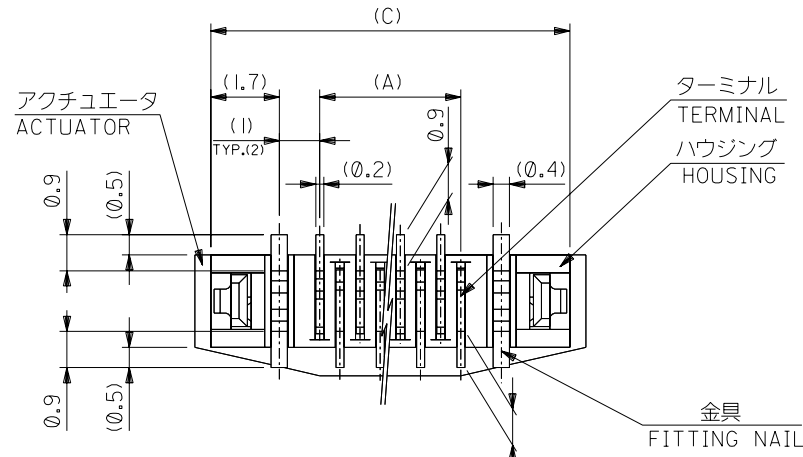

下面図  
BOTTOM VIEW

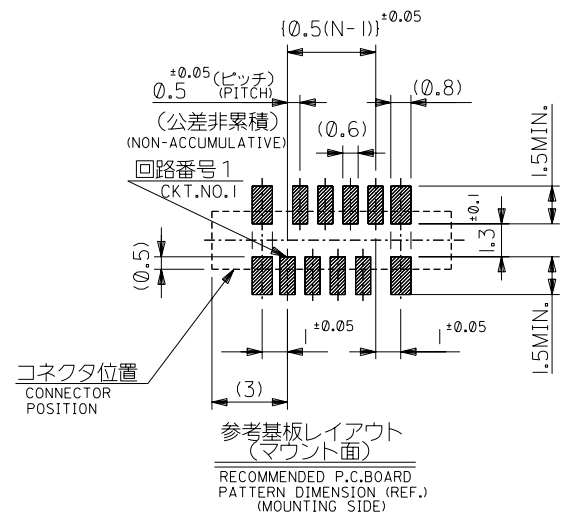
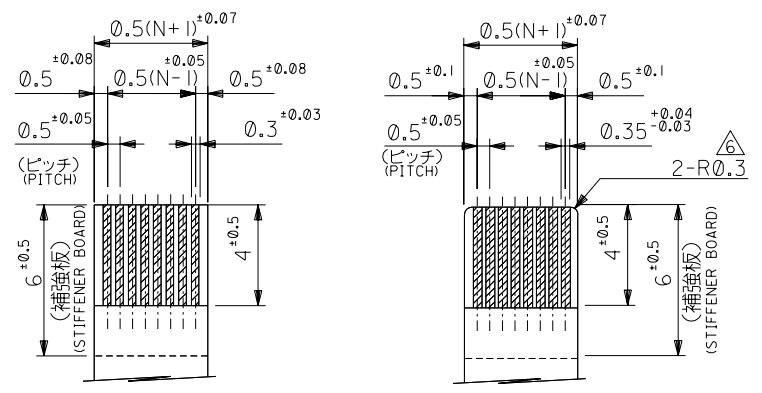

25.7	24.9	20.65	19.5	52559-4019	40
23.7	22.9	18.65	17.5	-3619	36
22.2	21.4	17.15	16.0	-3319	33
21.7	20.9	16.65	15.5	-3219	32
21.2	20.4	16.15	15.0	-3119	31
20.7	19.9	15.65	14.5	-3019	30
20.2	19.4	15.15	14.0	-2919	29
19.7	18.9	14.65	13.5	-2819	28
19.2	18.4	14.15	13.0	-2719	27
18.7	17.9	13.65	12.5	-2619	26
18.2	17.4	13.15	12.0	-2519	25
17.7	16.9	12.65	11.5	-2419	24
17.2	16.4	12.15	11.0	-2319	23
16.7	15.9	11.65	10.5	-2219	22
16.2	15.4	11.15	10.0	-2119	21
15.7	14.9	10.65	9.5	-2019	20
15.2	14.4	10.15	9.0	-1919	19
14.7	13.9	9.65	8.5	-1819	18
14.2	13.4	9.15	8.0	-1719	17
13.7	12.9	8.65	7.5	-1619	16
13.2	12.4	8.15	7.0	-1519	15
12.7	11.9	7.65	6.5	-1419	14
12.2	11.4	7.15	6.0	-1319	13
11.7	10.9	6.65	5.5	-1219	12
11.2	10.4	6.15	5.0	-1119	11
10.7	9.9	5.65	4.5	-1019	10
10.2	9.4	5.15	4.0	-0919	9
9.7	8.9	4.65	3.5	-0819	8
8.7	7.9	3.65	2.5	52559-0619	6
D	C	B	(A)	MATERIAL NO.	極致

図番NO. DRAWN: CH'K: APPR: 図番NO. DRAWN: CH'K: APPR: 図番NO. DRAWN: CH'K: APPR:	REVISED 図番NO. J2004-3551 DRAWN: H.KAWABATA '04/04/05 CH'K: K.TOJO '04/04/05 APPR: H. Saitoh '04/04/05 RELEASED 図番NO. J2004-1818 DRAWN: H.SHIMABUKURO '04/01/07 CH'K: K.TOJO '04/01/07 APPR: H. Saitoh '04/01/07	MATERIAL 材料 注記参照 SEE NOTES FINISH 仕上げ WIRE RANGE 適用 層線範囲 INS. RANGE 被覆 外径	GENERAL TOLERANCES: (UNLESS SPECIFIED) 一般公差 10 UNDER 未満 ±0.2 10 OVER 以上 30 UNDER 未満 ±0.25 30 OVER 以上 ±0.3 ANGLE 角度 ±3°	SCALE 縮尺 DESIGN UNITS 設計単位 図形投影角 DIMENSIONS: 寸法 mm INCH mm ONLY INCH TITLE: 0.5 FPC Conn. Assy ZIF. -LEAD FREE- MOLEX MOLEX INCORPORATED	MODEL NO. 52559-***19 DIMENSIONS: 寸法 mm INCH mm ONLY INCH TITLE: 0.5 FPC Conn. Assy ZIF. -LEAD FREE- MOLEX MOLEX INCORPORATED MATERIAL NO. SEE CHART DRAWING NO. SD-52559-045 SHEET NO. 2 OF 2
---	--	--	--	--	---

8 7 6 5 4 3 2 1

SD-52559-045:SA