

Distributed by:

**JAMECO**<sup>®</sup>  
ELECTRONICS

**www.Jameco.com ♦ 1-800-831-4242**

The content and copyrights of the attached  
material are the property of its owner.

Jameco Part Number 1301796



PRODUCT SPECIFICATION



LANGUAGE

JAPANESE  
ENGLISH

【1. 適用範囲 SCOPE】

本仕様書は、 \_\_\_\_\_ 殿 に納入する  
0.5mm ピッチ FPC用 コネクタ について規定する。

This specification covers the 0.5mm PITCH FPC CONNECTOR series.

【2. 製品名称及び型番 PRODUCT NAME AND PART NUMBER】

製品名称 Product Name		製品型番 Parts Number
ハウジング アッセンブリ Housing Assembly (STRAIGHT TYPE)	(無鉛) LEAD FREE	52746-**19
52746-**19 エンボス梱包品 Embossed Tape Package for 52746-**19	(無鉛) LEAD FREE	52746-**70

\*\* : 図面参照 Refer to the drawing.

【3. 定格 RATINGS】

項目 Item	規格 Standard	
最大許容電圧 Rated Voltage (MAXIMUM)	50 V	[AC(実効値 rms) / DC]
最大許容電流 Rated Current (MAXIMUM)	0.5 A	
使用温度範囲 Ambient Temperature Range.	-20°C ~ +85°C <sup>*1</sup>	

\*1 : 通電による温度上昇分も含む。  
Including terminal temperature rise.

REV.	A	B													
SHEET	1~9	1~10													
REVISE ON PC ONLY						TITLE: 0.5mm PITCH FPC CONN.									
<b>B</b>	変更 REVISED J2005-1135 '04/10/21 N.AIDA					-LEAD FREE- 製品仕様書									
	THIS DOCUMENT CONTAINS INFORMATION THAT IS PROPRIETARY TO MOLEX INC. AND SHOULD NOT BE USED WITHOUT WRITTEN PERMISSION														
REV.	DESCRIPTION					WRITTEN BY: E.SUZUKI	CHECKED BY: K.TOJO	APPROVED BY: M.SASAO	DATE: YR/MO/DAY 2004/02/03						
DESIGN CONTROL J						STATUS						FILE NAME PS52746016.doc	SHEET 1 OF 10		
DOCUMENT NUMBER <b>PS-52746-016</b>															



PRODUCT SPECIFICATION



LANGUAGE

JAPANESE  
ENGLISH

【4. 性能 PERFORMANCE】

4-1. 電気的性能 Electrical Performance

項目 Item	条件 Condition	規格 Standard
4-1-1 接触抵抗 Contact Resistance	適合FPCを嵌合させ、開放電圧 20mV以下、 短絡電流 10mA にて測定する。 (JIS C5402 5.4) Mate applicable FPC, measure by dry circuit, 20mV MAXIMUM, 10mA. (JIS C5402 5.4)	20 milliohm MAXIMUM
4-1-2 絶縁抵抗 Insulation Resistance	適合FPCを嵌合させ、隣接するターミナル間及びターミナル、アース間に、DC 500V を印加し測定する。 (JIS C5402 5.2/MIL-STD-202 試験法 302) Mate applicable FPC, apply 500V DC between adjacent terminal or ground. (JIS C5402 5.2/MIL-STD-202 Method 302)	50 Megohm MINIMUM
4-1-3 耐電圧 Dielectric Strength	適合FPCを嵌合させ、隣接するターミナル間及びターミナル、アース間に、AC 250V (実効値) を 1分間 印加する。 (JIS C5402 5.1/MIL-STD-202 試験法 301) Mate applicable FPC, apply 250V AC (rms) for 1 minute between adjacent terminal or ground. (JIS C5402 5.1/MIL-STD-202 Method 301)	異常なきこと No Breakdown

4-2. 機械的性能 Mechanical Performance

項目 Item	条件 Condition	規格 Standard
4-2-1 アクチュエータ 挿抜力 Actuator and Withdrawal Force	適合FPCを嵌合させ、アクチュエータを 毎分 25±3mm の速さで挿入、抜去を行う。 Mate applicable FPC and Insert and withdraw actuator at the speed rate of 25±3mm/minute.	第6項参照 Refer to paragraph 6
4-2-2 FPC保持力 FPC Retention Force	アクチュエータ挿入状態にて、毎分 25±3mm の速さで FPCを引き抜く。 Insert the actuator, pull the FPC at the speed rate of 25±3mm/minute.	第7項参照 Refer to paragraph 7

REVISE ON PC ONLY		TITLE:  0.5mm PITCH FPC CONN.  -LEAD FREE- 製品仕様書
<b>B</b>	SEE SHEET 1 OF 10	
REV.	DESCRIPTION	THIS DOCUMENT CONTAINS INFORMATION THAT IS PROPRIETARY TO MOLEX INC. AND SHOULD NOT BE USED WITHOUT WRITTEN PERMISSION

DOCUMENT NUMBER <b>PS-52746-016</b>	FILE NAME PS52746016.doc	SHEET 2 OF 10
--	-----------------------------	------------------



PRODUCT SPECIFICATION



LANGUAGE

JAPANESE  
ENGLISH

項目 Item	条件 Condition	規格 Standard
4-2-3 端子保持力 Terminal / Housing Retention Force	端子を 毎分 25±3mm の速さで引張る。 Apply axial pull out force at the speed rate of 25±3mm/minute on the terminal assembled in the housing.	3.0 N {0.30 kgf} MINIMUM
4-2-4 金具保持力 Fitting nail/ Housing Retention Force	金具を 毎分 25±3mm の速さで引張る。 Apply axial pull out force at the speed rate of 25±3mm/minute on the fitting nail assembled in the housing.	3.0 N {0.30 kgf} MINIMUM

4-3. その他 Environmental Performance and Others

項目 Item	条件 Condition	規格 Standard	
4-3-1 アクチュエータ 繰返し動作 Repeated Actuator Insertion / Withdrawal	無通電状態にて、1分間に 10回以下の速さで挿入、抜去を 20回 繰り返す。 Insert and withdraw actuator up to 20 cycles at the speed rate of less than 10 cycles/minute.	接触抵抗 Contact Resistance	40 milliohm MAXIMUM
4-3-2 温度上昇 Temperature Rise	適合FPCを嵌合させ、最大許容電流を通電し、コネクタの温度上昇分を測定する。 (UL 498) Carrying rated current load. (UL 498)	温度上昇 Temperature Rise	30 °C MAXIMUM
4-3-3 耐振動性 Vibration	DC 1mA 通電状態にて、嵌合軸を含む互いに垂直な3方向 に掃引割合 10~55~10Hz/分、全振幅 1.5mm の振動を 各2時間 加える。 (MIL-STD-202 試験法 201) Amplitude : 1.5mm P-P Sweep time : 10~55~10Hz in 1 minute Duration : 2 hours in each X, Y, Z axes (MIL-STD-202 Method 201)	外観 Appearance	異常なきこと No damage
		接触抵抗 Contact Resistance	40 milliohm MAXIMUM
		瞬断 Discontinuity	1.0 microsecond MAXIMUM

REVISE ON PC ONLY	
<b>B</b>	SEE SHEET 1 OF 10
REV.	DESCRIPTION

TITLE:  
0.5mm PITCH FPC CONN.  
-LEAD FREE- 製品仕様書

THIS DOCUMENT CONTAINS INFORMATION THAT IS PROPRIETARY TO MOLEX INC. AND SHOULD NOT BE USED WITHOUT WRITTEN PERMISSION

DOCUMENT NUMBER <b>PS-52746-016</b>	FILE NAME PS52746016.doc	SHEET 3 OF 10
--	-----------------------------	------------------



PRODUCT SPECIFICATION



LANGUAGE

JAPANESE  
ENGLISH

項目 Item		条件 Condition	規格 Standard	
4-3-4	耐衝撃性 Shock	DC 1mA 通電状態にて、嵌合軸を含む互いに垂直な6方向に 490m/s <sup>2</sup> {50G} の衝撃を各3回加える。 (JIS C0041/MIL-STD-202 試験法 213)  490m/s <sup>2</sup> {50G}, 3 strokes in each X,Y,Z axes. (JIS C0041/MIL-STD-202 Method 213)	外観 Appearance	異常なきこと No damage
			接触抵抗 Contact Resistance	40 milliohm MAXIMUM
			瞬断 Discontinuity	1.0 microsecond MAXIMUM
4-3-5	耐熱性 Heat Resistance	適合FPCを嵌合させ、85±2°C の雰囲気中に 96時間放置後取り出し、1~2時間室温に放置する。 (JIS C0021/MIL-STD-202 試験法 108)  85±2°C, 96 hours (JIS C0021/MIL-STD-202 Method 108)	外観 Appearance	異常なきこと No damage
			接触抵抗 Contact Resistance	40 milliohm MAXIMUM
4-3-6	耐寒性 Cold Resistance	適合FPCを嵌合させ、-40±2°C の雰囲気中に 96時間放置後取り出し、1~2時間室温に放置する。 (JIS C0020)  -40±2°C, 96 hours (JIS C0020)	外観 Appearance	異常なきこと No damage
			接触抵抗 Contact Resistance	40 milliohm MAXIMUM
4-3-7	耐湿性 Humidity	適合FPCを嵌合させ、60±2°C、相対湿度 90~95% の雰囲気中に 96時間放置後取り出し、1~2時間室温に放置する。 (JIS C0022/MIL-STD-202 試験法103)  Temperature : 60±2°C Relative Humidity : 90~95% Duration : 96 hours (JIS C0022/MIL-STD-202 Method 103)	外観 Appearance	異常なきこと No damage
			接触抵抗 Contact Resistance	40 milliohm MAXIMUM
			耐電圧 Dielectric Strength	4-1-3項 満足のこと Must meet 4-1-3
			絶縁抵抗 Insulation Resistance	20 Megohm MINIMUM
4-3-8	温度サイクル Temperature Cycling	適合FPCを嵌合させ、-55°Cに30分、+85°Cに30分、これを1サイクルとし、5サイクル繰り返す。但し、温度移行時間は5分以内とする。試験後、1~2時間室温に放置する。 (JIS C0025)  5 cycles of : a) -55°C 30 minutes b) +85°C 30 minutes (JIS C0025)	外観 Appearance	異常なきこと No damage
			接触抵抗 Contact Resistance	40 milliohm MAXIMUM

REVISE ON PC ONLY		TITLE:  0.5mm PITCH FPC CONN.  -LEAD FREE- 製品仕様書
<b>B</b>	SEE SHEET 1 OF 10	
REV.	DESCRIPTION	THIS DOCUMENT CONTAINS INFORMATION THAT IS PROPRIETARY TO MOLEX INC. AND SHOULD NOT BE USED WITHOUT WRITTEN PERMISSION

DOCUMENT NUMBER <b>PS-52746-016</b>	FILE NAME PS52746016.doc	SHEET 4 OF 10
--	-----------------------------	------------------



PRODUCT SPECIFICATION



LANGUAGE

JAPANESE  
ENGLISH

項 目 Item		条 件 Condition	規 格 Standard	
4-3-9	塩水噴霧 Salt Spray	適合FPCを嵌合させ、35±2℃にて5±1%重量比の塩水を48±4時間噴霧し、試験後、常温で水洗いした後、室温で乾燥させる。 (JIS C5028/MIL-STD-202 試験法101)  48±4 hours exposure to a salt spray from the 5±1% solution at 35±2℃. (JIS C5028/MIL-STD-202 Method 101)	外 観 Appearance	異常なきこと No damage
			接触抵抗 Contact Resistance	40 milliohm MAXIMUM
4-3-10	亜硫酸ガス SO <sub>2</sub> Gas	適合FPCを嵌合させ、40±2℃にて50±5ppmの亜硫酸ガス中に24時間放置する。  24 hours exposure to 50±5ppm. SO <sub>2</sub> gas at 40±2℃.	外 観 Appearance	異常なきこと No damage
			接触抵抗 Contact Resistance	40 milliohm MAXIMUM
4-3-11	耐アンモニア性 NH <sub>3</sub> Gas	適合FPCを嵌合させ、濃度28%のアンモニア水を入れた容器中に40分間放置する。 (1Lに対して25mlの割合)  40 minutes exposure to NH <sub>3</sub> gas evaporating from 28% Ammonia solution.	外 観 Appearance	異常なきこと No damage
			接触抵抗 Contact Resistance	40 milliohm MAXIMUM
4-3-12	半田付け性 Solderability	端子先端より0.3mm、金具先端より0.3mmの位置まで245±3℃の半田に3±0.5秒浸す。  Dip terminal and fitting nail (held at 245±3℃) up to 0.3mm from the tip for 3±0.5 seconds.	濡れ性 Solder Wetting	浸漬面積の90%以上 90% of immersed area must show no voids, pin holes
4-3-13	半田耐熱性 Resistance to Soldering Heat	(リフロー時) 第8項の条件を2回繰り返す。  (When reflowing) Repeat paragraph 8, condition two times.	外 観 Appearance	端子ガタ、割れ等 異常なきこと No damage
		(手半田時) 端子先端より0.3mm、金具先端まで0.3mmの位置まで、370~400℃の半田ゴテにて最大5秒加熱後。  Dip terminal and fitting nail (held at 370~400℃) up to 0.3mm from the tip for 5 seconds MAXIMUM.		

( ): 参考規格 Reference Standard  
{ }: 参考単位 Reference Unit

REVISE ON PC ONLY		TITLE:	
<b>B</b>	SEE SHEET 1 OF 10	0.5mm PITCH FPC CONN.	
	REV.	DESCRIPTION	-LEAD FREE- 製品仕様書
DOCUMENT NUMBER <b>PS-52746-016</b>		THIS DOCUMENT CONTAINS INFORMATION THAT IS PROPRIETARY TO MOLEX INC. AND SHOULD NOT BE USED WITHOUT WRITTEN PERMISSION	
		FILE NAME PS52746016.doc	SHEET 5 OF 10
EN-37-1(019)			



# PRODUCT SPECIFICATION



LANGUAGE

JAPANESE  
ENGLISH**【5. 外観形状、寸法及び材質 PRODUCT SHAPE, DIMENSIONS AND MATERIALS】**

図面参照 Refer to the drawing.

**【6. アクチュエータ挿抜力 ACTUATOR INSERTION AND WITHDRAWAL FORCE】**

極数 No. of CIRCUIT	単位 UNIT	挿入力 (最大値) INSERTION FORCE (MAXIMUM)			抜去力 (最大値) WITHDRAWAL FORCE (MAXIMUM)		
		初回 1st	6回目 6th	20回目 20th	初回 1st	6回目 6th	20回目 20th
4	N {kgf}	28.4 {2.9}	26.4 {2.7}	26.4 {2.7}	37.2 {3.8}	33.3 {3.4}	33.3 {3.4}
6	N {kgf}	30.3 {3.1}	28.4 {2.9}	28.4 {2.9}	39.2 {4.0}	35.2 {3.6}	35.2 {3.6}
7	N {kgf}	31.3 {3.2}	29.4 {3.0}	29.4 {3.0}	40.1 {4.1}	36.2 {3.7}	36.2 {3.7}
8	N {kgf}	32.3 {3.3}	30.3 {3.1}	30.3 {3.1}	41.1 {4.2}	37.2 {3.8}	37.2 {3.8}
9	N {kgf}	33.3 {3.4}	31.3 {3.2}	31.3 {3.2}	42.1 {4.3}	38.2 {3.9}	38.2 {3.9}
10	N {kgf}	34.3 {3.5}	32.3 {3.3}	32.3 {3.3}	43.1 {4.4}	39.2 {4.0}	39.2 {4.0}
11	N {kgf}	35.2 {3.6}	33.3 {3.4}	33.3 {3.4}	44.1 {4.5}	40.1 {4.1}	40.1 {4.1}
12	N {kgf}	36.2 {3.7}	34.3 {3.5}	34.3 {3.5}	45.0 {4.6}	41.1 {4.2}	41.1 {4.2}
13	N {kgf}	37.2 {3.8}	35.2 {3.6}	35.2 {3.6}	46.1 {4.7}	42.2 {4.3}	42.2 {4.3}
14	N {kgf}	38.2 {3.9}	36.2 {3.7}	36.2 {3.7}	47.0 {4.8}	43.1 {4.4}	43.1 {4.4}
15	N {kgf}	39.2 {4.0}	37.2 {3.8}	37.2 {3.8}	48.0 {4.9}	44.1 {4.5}	44.1 {4.5}
16	N {kgf}	40.1 {4.1}	38.2 {3.9}	38.2 {3.9}	49.0 {5.0}	45.0 {4.6}	45.0 {4.6}
17	N {kgf}	41.1 {4.2}	39.2 {4.0}	39.2 {4.0}	49.9 {5.1}	46.0 {4.7}	46.0 {4.7}
18	N {kgf}	42.1 {4.3}	40.1 {4.1}	40.1 {4.1}	50.9 {5.2}	47.0 {4.8}	47.0 {4.8}
19	N {kgf}	43.1 {4.4}	41.1 {4.2}	41.1 {4.2}	51.9 {5.3}	48.0 {4.9}	48.0 {4.9}
20	N {kgf}	44.1 {4.5}	42.1 {4.3}	42.1 {4.3}	52.9 {5.4}	49.0 {5.0}	49.0 {5.0}

REVISE ON PC ONLY

**B**

SEE SHEET 1 OF 10

TITLE:

0.5mm PITCH FPC CONN.

-LEAD FREE-

製品仕様書

THIS DOCUMENT CONTAINS INFORMATION THAT IS PROPRIETARY TO  
MOLEX INC. AND SHOULD NOT BE USED WITHOUT WRITTEN PERMISSION

REV.

DESCRIPTION

DOCUMENT NUMBER

**PS-52746-016**

FILE NAME

PS52746016.doc

SHEET

6 OF 10

EN-37-1(019)



PRODUCT SPECIFICATION



LANGUAGE

JAPANESE  
ENGLISH

極数 No. of CIRCUIT	単位 UNIT	挿入力 (最大値) INSERTION FORCE (MAXIMUM)			抜去力 (最大値) WITHDRAWAL FORCE (MAXIMUM)		
		初回 1st	6回目 6th	20回目 20th	初回 1st	6回目 6th	20回目 20th
21	N {kgf}	45.0 {4.6}	43.1 {4.4}	43.1 {4.4}	53.9 {5.5}	49.9 {5.1}	49.9 {5.1}
22	N {kgf}	46.0 {4.7}	44.1 {4.5}	44.1 {4.5}	54.8 {5.6}	50.9 {5.2}	50.9 {5.2}
23	N {kgf}	47.0 {4.8}	45.0 {4.6}	45.0 {4.6}	55.8 {5.7}	51.9 {5.3}	51.9 {5.3}
24	N {kgf}	48.0 {4.9}	46.0 {4.7}	46.0 {4.7}	56.8 {5.8}	52.9 {5.4}	52.9 {5.4}
25	N {kgf}	49.0 {5.0}	47.0 {4.8}	47.0 {4.8}	57.8 {5.9}	53.9 {5.5}	53.9 {5.5}
26	N {kgf}	49.9 {5.1}	48.0 {4.9}	48.0 {4.9}	58.8 {6.0}	54.8 {5.6}	54.8 {5.6}
27	N {kgf}	50.9 {5.2}	49.0 {5.0}	49.0 {5.0}	59.7 {6.1}	55.8 {5.7}	55.8 {5.7}
28	N {kgf}	51.9 {5.3}	49.9 {5.1}	49.9 {5.1}	60.7 {6.2}	56.8 {5.8}	56.8 {5.8}
29	N {kgf}	52.9 {5.4}	50.9 {5.2}	50.9 {5.2}	61.7 {6.3}	57.8 {5.9}	57.8 {5.9}
30	N {kgf}	53.9 {5.5}	51.9 {5.3}	51.9 {5.3}	62.7 {6.4}	58.8 {6.0}	58.8 {6.0}

REVISE ON PC ONLY		TITLE:	
<b>B</b>	SEE SHEET 1 OF 10	0.5mm PITCH FPC CONN.	
		-LEAD FREE- 製品仕様書	
REV.	DESCRIPTION	THIS DOCUMENT CONTAINS INFORMATION THAT IS PROPRIETARY TO MOLEX INC. AND SHOULD NOT BE USED WITHOUT WRITTEN PERMISSION	
DOCUMENT NUMBER <b>PS-52746-016</b>		FILE NAME PS52746016.doc	SHEET 7 OF 10
EN-37-1(019)			





# PRODUCT SPECIFICATION



LANGUAGE

JAPANESE  
ENGLISH

## 【7. FPC保持力 FPC RETENTION FORCE】

極数 No. of CIRCUIT	単位 UNIT	保持力 (最小値) RETENTION FORCE (MINIMUM)		極数 No. of CIRCUIT	単位 UNIT	保持力 (最小値) RETENTION FORCE (MINIMUM)	
		初回 1st	10回目 10th			初回 1st	10回目 10th
4	N {kgf}	1.5 {0.15}	1.4 {0.14}	18	N {kgf}	8.4 {0.85}	5.5 {0.56}
6	N {kgf}	2.5 {0.25}	2.0 {0.20}	19	N {kgf}	8.9 {0.90}	5.8 {0.59}
7	N {kgf}	3.0 {0.30}	2.3 {0.23}	20	N {kgf}	9.4 {0.95}	6.1 {0.62}
8	N {kgf}	3.5 {0.35}	2.6 {0.26}	21	N {kgf}	9.8 {1.00}	6.4 {0.65}
9	N {kgf}	4.0 {0.40}	2.9 {0.29}	22	N {kgf}	10.3 {1.05}	6.7 {0.68}
10	N {kgf}	4.5 {0.45}	3.2 {0.32}	23	N {kgf}	10.8 {1.10}	7.0 {0.71}
11	N {kgf}	4.9 {0.50}	3.5 {0.35}	24	N {kgf}	11.3 {1.15}	7.3 {0.74}
12	N {kgf}	5.4 {0.55}	3.8 {0.38}	25	N {kgf}	11.8 {1.20}	7.6 {0.77}
13	N {kgf}	5.9 {0.60}	4.1 {0.41}	26	N {kgf}	12.3 {1.25}	7.9 {0.80}
14	N {kgf}	6.4 {0.65}	4.4 {0.44}	27	N {kgf}	12.8 {1.30}	8.2 {0.83}
15	N {kgf}	6.9 {0.70}	4.6 {0.47}	28	N {kgf}	13.3 {1.35}	8.5 {0.86}
16	N {kgf}	7.4 {0.75}	4.9 {0.50}	29	N {kgf}	13.8 {1.40}	8.8 {0.89}
17	N {kgf}	7.9 {0.80}	5.2 {0.53}	30	N {kgf}	14.3 {1.45}	9.1 {0.92}

REVISE ON PC ONLY

**B**

SEE SHEET 1 OF 10

TITLE:

0.5mm PITCH FPC CONN.

-LEAD FREE-

製品仕様書

THIS DOCUMENT CONTAINS INFORMATION THAT IS PROPRIETARY TO  
MOLEX INC. AND SHOULD NOT BE USED WITHOUT WRITTEN PERMISSION

REV.

DESCRIPTION

DOCUMENT NUMBER

**PS-52746-016**

FILE NAME

PS52746016.doc

SHEET

8 OF 10

EN-37-1(019)



【8. 赤外線リフロー条件 INFRARED REFLOW CONDITION】

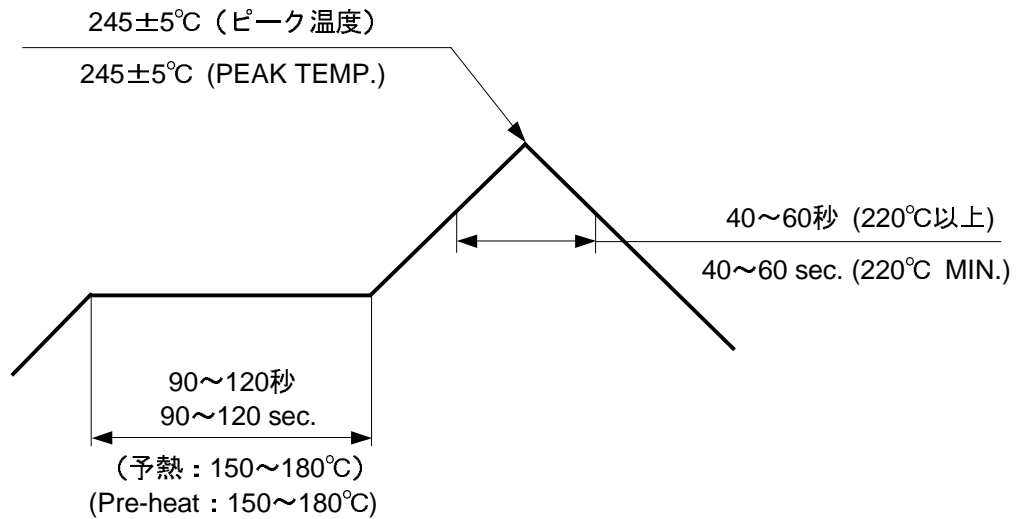

温度条件グラフ  
(温度は基板パターン面)

TEMPERATURE CONDITION GRAPH  
(TEMPERATURE ON THE SURFACE OF P.C.BOARD PATTERN)

注記 ; 本リフロー条件に関しては、リフロー装置及び基板などにより条件が異なりますので、事前にリフロー評価の確認をお願い致します。  
また吸湿などの前処理は行わないで下さい。

NOTE ; Please check the reflow soldering condition by your own devices beforehand.  
Because the condition changes by the soldering devices, P.C.Boards, and so on.  
No moisture treatment before reflow process.

REVISE ON PC ONLY		TITLE:	
<b>B</b>	SEE SHEET 1 OF 10	0.5mm PITCH FPC CONN.	
		-LEAD FREE-	製品仕様書
REV.	DESCRIPTION	THIS DOCUMENT CONTAINS INFORMATION THAT IS PROPRIETARY TO MOLEX INC. AND SHOULD NOT BE USED WITHOUT WRITTEN PERMISSION	
DOCUMENT NUMBER <b>PS-52746-016</b>		FILE NAME PS52746016.doc	SHEET 9 OF 10
EN-37-1(019)			



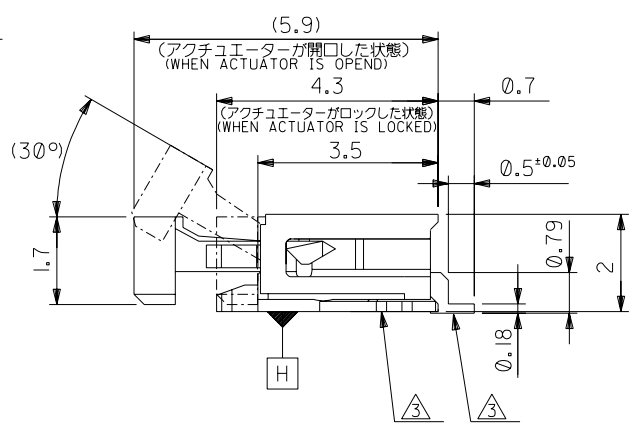
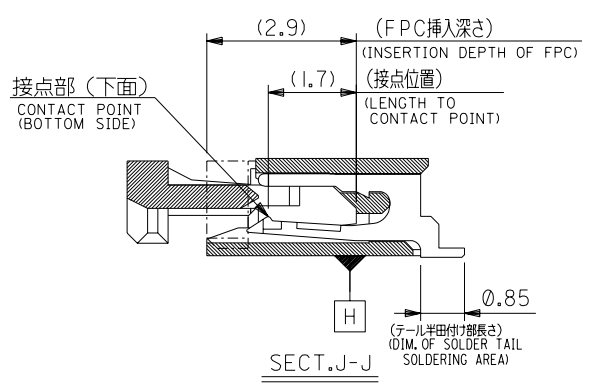
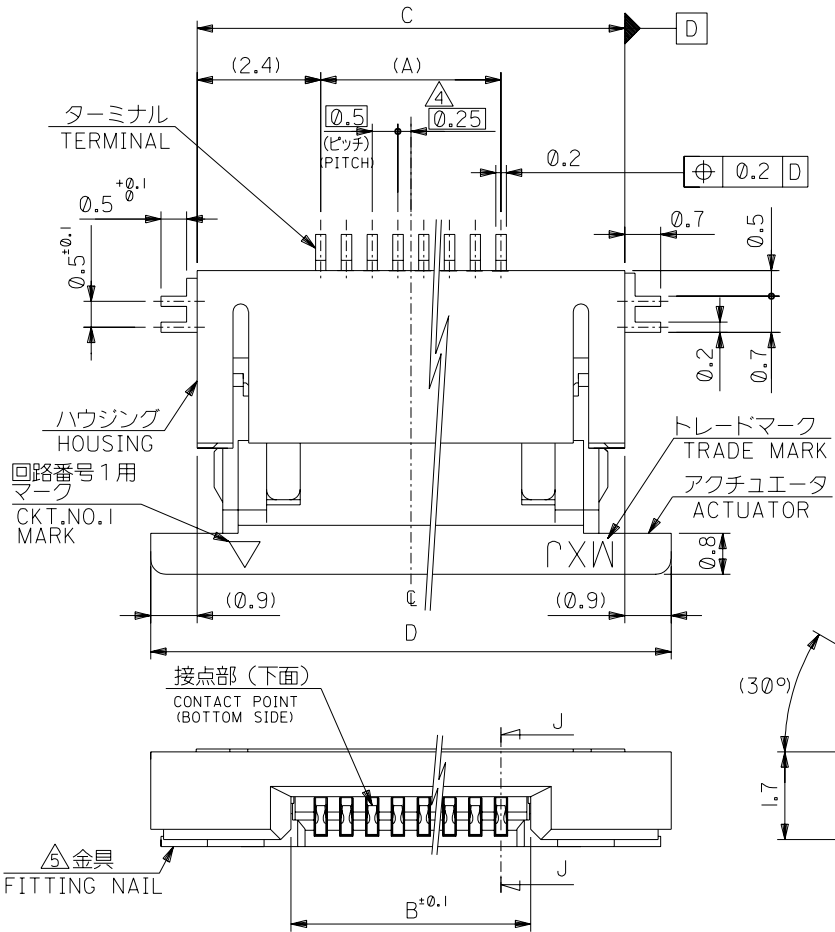

16.1	14.3	10.65	9.5	52746-2017	20
15.6	13.8	10.15	9.0	-1917	19
15.1	13.3	9.65	8.5	-1817	18
14.6	12.8	9.15	8.0	-1717	17
14.1	12.3	8.65	7.5	-1617	16
13.6	11.8	8.15	7.0	-1517	15
13.1	11.3	7.65	6.5	-1417	14
12.6	10.8	7.15	6.0	-1317	13
12.1	10.3	6.65	5.5	-1217	12
11.6	9.8	6.15	5.0	-1117	11
11.1	9.3	5.65	4.5	-1017	10
10.6	8.8	5.15	4.0	-0917	9
10.1	8.3	4.65	3.5	-0817	8
9.6	7.8	4.15	3.0	-0717	7
9.1	7.3	3.65	2.5	-0617	6
8.1	6.3	2.65	1.5	52746-0417	4
D	C	B	(A)	MATERIAL NO.	極数 CIRCUIT

注記 NOTES

- 使用材料 MATERIAL  
 ハウジング : 46ナイロン, UL94V-0  
 HOUSING : 46NYLON  
 アクチュエータ : PPS, UL94V-0  
 ACTUATOR  
 ターミナル : リン青銅, 半田メッキ (t=0.2)  
 TERMINAL : PHOS-BRO, TIN-LEAD PLATED  
 金具 : リン青銅, 半田メッキ (t=0.2)  
 FITTING NAIL : PHOS-BRO, TIN-LEAD PLATED
  - エンボステープ梱包時は、アクチュエータがロックした状態とする。  
 IN THE PACKAGE, ACTUATOR OF PART NO.52746-\*\*-17 SHOULD BE LOCKED.
- △ソルダータール半田付け面のスレ量、及び金具半田付け面のスレ量は、基準面 [H] に対し上方向 0.1MAX. 下方向 0.15MAX. とする。  
 MISALIGNMENT OF SOLDER TAILS AND FITTING NAILS FROM [H]  
 UPPER DIRECTION: 0.1 MAX. , LOWER DIRECTION: 0.15MAX.
- △偶数極に適用。  
 APPLY FOR EVEN CIRCUIT.
- △パターンはくり止め用金具  
 FITTING NAIL FOR PREVENTION OF PEELING OF P.C.B. PATTERN.

角度 ANGLE	±3°
30° 以上 OVER	+0.3
10° 以上 30° 未満 OVER	+0.25
10° 未満 UNDER	+0.2
一般公差 GENERAL TOLERANCES	

記号 LTR	変更内容 REVISION RECORD	日付 DATE	DR. CHK.
①	新規/作成 RELEASED (J40230)	'94/3/24	S.A. S.K.
②	変更 REVISD (JC60146)	'95/9/6	T.N. H.H.
③	変更 REVISD (JC80041)	'97/7/15	H.I. M.F.
④	変更 REVISD (UC2000-0795)	'00/6/30	N.Y. M.S.
⑤	変更 REVISD (J2004-4506)	'04/5/31	M.N. S.K.

材料 MATERIAL	注記参照 SEE NOTES
仕上げ FINISH	注記参照 SEE NOTES
適用電線範囲 WIRE RANGE	—//—
被覆外径 INS. RANGE	—//—
DRAWN BY '94/3/24 S.AIHARA	CHK'D BY '00/6/30 S.KUNISHI
APP'D BY '00/6/30 M.FUKUSHIMA	尺度 SCALE —//—

molex MOLEX-JAPAN CO.,LTD.  
 日本モレックス株式会社

REVISE ONLY ON CAD SYSTEM  
 TITLE 名称

0.5 FPC CONN. Z.I.F. FOR SMT.R/A(BOTTOM CONTACT)

DWG. NO. (SHEET 1 OF 2) REV E  
 SD-52746-\*\*-17

8 7 6 5 4 3 2 1

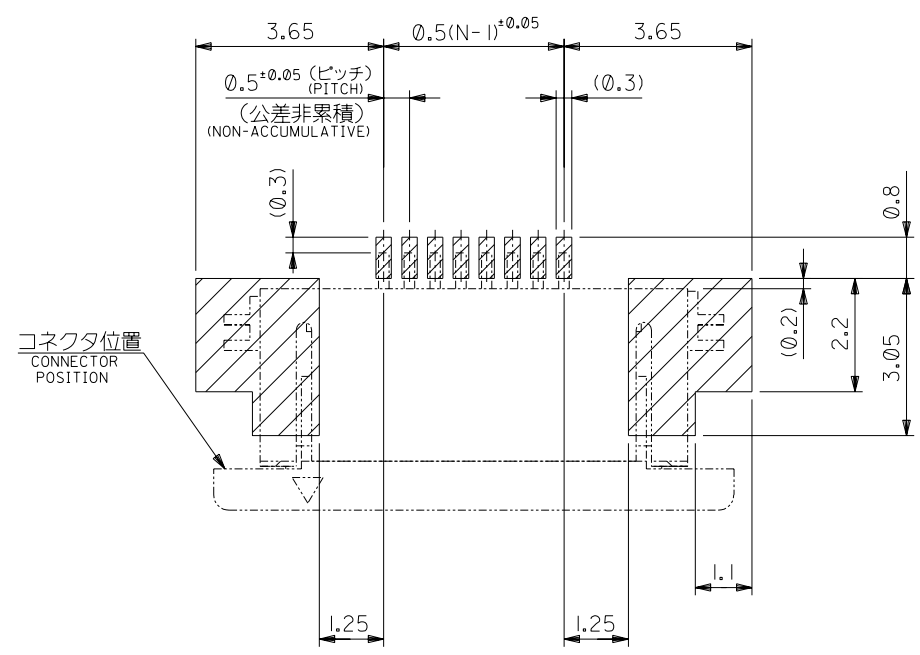

参考基板レイアウト  
RECOMMENDED P.C. BOARD  
PATTERN DIMENSION (REF.)  
(マウント面)

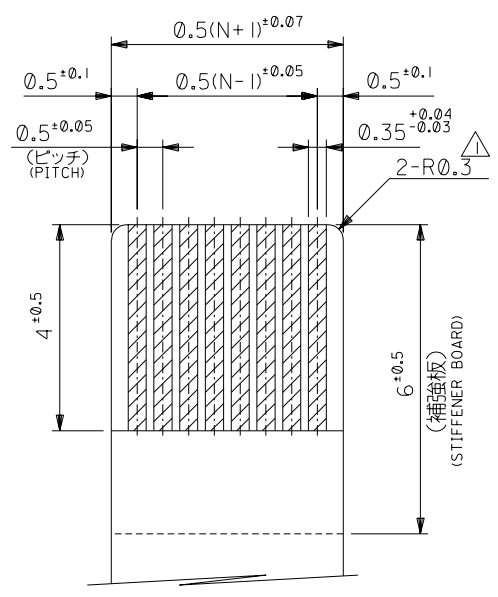

適合FPC推奨寸法  
APPLICABLE FPC  
RECOMMENDED DIMENSION  
(仕上がり厚さ: 0.3±0.03)  
(THICKNESS: 0.3±0.03)

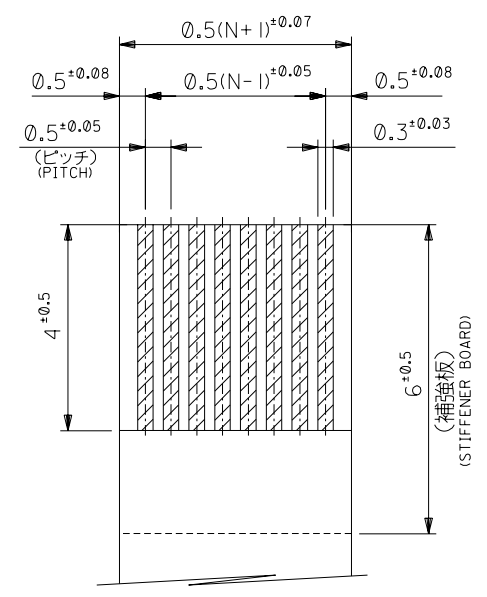

適合FPC推奨寸法  
APPLICABLE FPC  
RECOMMENDED DIMENSION  
(仕上がり厚さ: 0.3±0.03)  
(THICKNESS: 0.3±0.03)

注記 NOTES

△ R0.3は、FPCの導体部にかからないこと。  
R0.3 MUST NOT BE OVERLAPPED TO PATTERN OF FPC.

		材料 MATERIAL		MATERIAL —//—		molex MOLEX-JAPAN CO.,LTD. 日本モレックス株式会社	
E		変更 REVISD (J2004-4506)	M.N	04/5/31	仕上げ FINISH 注記参照 SEE NOTES		REVISE ONLY ON CAD SYSTEM
D		変更 REVISD (JC2000-0795)	N.Y.S	00/6/30	適用電線範囲 WIRE RANGE		TITLE 名称
C		変更 REVISD (JC80041)	T.N.M	97/7/15	被覆外径 INS. RANGE		0.5 FPC CONN. Z.I.F. FOR SMT.R/A(BOTTOM CONTACT)
B		変更 REVISD (JC60146)	T.N.H	95/9/6	DRAWN BY '94/3/24 S.AIHARA		CHK'D BY '00/6/30 S.KUNISHI
A		変更 REVISD (J40949)	Y.M.H	94/11/17	DRAWN BY '94/3/24 S.AIHARA		CHK'D BY '00/6/30 S.KUNISHI
0		新規作成 RELEASED (J40230)	S.A	'94/3/24	APP'D BY '00/6/30 M.FUKUSHIMA		尺度 SCALE —//—
一般公差 GENERAL TOLERANCES		記号 LTR	変更内容 REVISION RECORD	DR. CHK.	日付 DATE	尺度 SCALE	—//—

8 7 6 5 4 3 2 1





DWG. NO.  
SD-52746-\*\*\*70

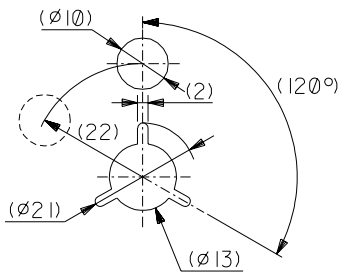
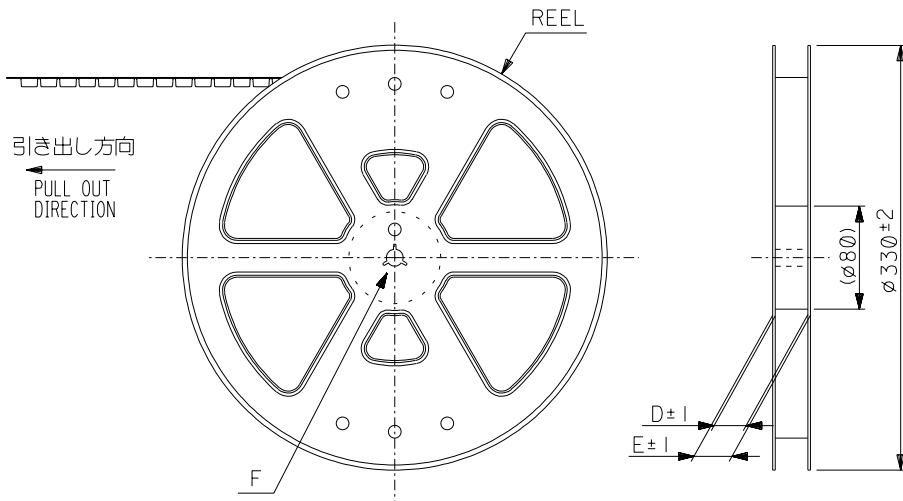

DETAIL F

5. 材料 キャリアテープ: ポリプロピレン (PP)  
 トップテープ: PET, PE, PEF  
 リール: ポリスチレン (PS) <リサイクル材を含む>

MATERIAL CARRIER TAPE: POLYPROPYLENE  
 TOP TAPE: PET, PE, PEF  
 REEL: POLYSTYRENE (PS)  
 <RECYCLE MATERIAL CONTAINED>

6. 本製品は 52746-\*\*\*90 の鉛フリー品です  
 THIS PRODUCT IS LEAD FREE OF 52746-\*\*\*90

注記 NOTES

1. 製品番号 52746-\*\*\*19 の梱包状態はアクチュエータがロックした状態とする。  
 詳細寸法については図面 SD-52746-\*\*\*19 を参照下さい。  
 IN THE PACKAGE, ACTUATOR OF PART NO. 52746-\*\*\*19 SHOULD BE LOCKED  
 RE DETAILED DIMENSIONS, SEE SD-52746-\*\*\*19

2. 梱包数量: 1000個/リール  
 NUMBER OF CONNECTORS: 1000PCS/REEL

3. リードテープ長さ LEAD TAPE LENGTH

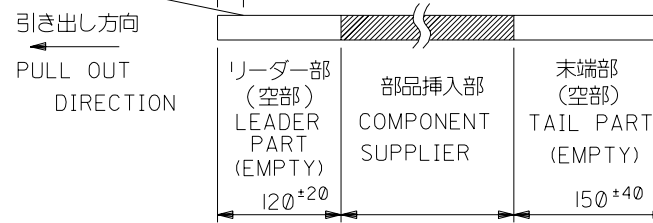
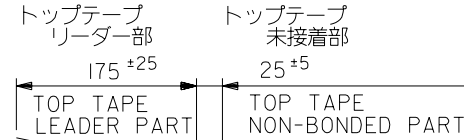

4. トップテープの剥離強度: (剥離方向は下図参照)  
 0.1N ~ 1.3N (10gf ~ 130gf) 尚、本規格値は、出荷時に適用。  
 (但し、輸送時に剥離が発生しない事。)

PEELING OFF FORCE OF TOP TAPE

0.1N ~ 1.3N (10gf ~ 130gf) (PEELING DIRECTION AS SHOWN IN FOLLOWING FIG.)  
 THIS REQUIREMENT SHOULD BE APPLIED AT SHIPMENT  
 PEEL OFF SHOULD NOT BE ALLOWED,  
 DURING TRANSPORTATION

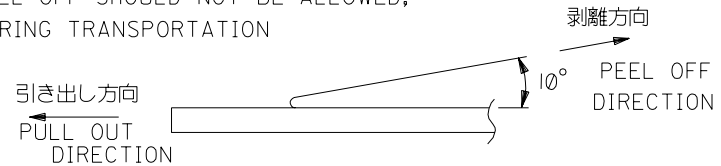

角度 ANGLE		±30°				材料 MATERIAL	注記参照 SEE NOTES	molex MOLEX-JAPAN CO.,LTD. 日本モレックス株式会社
30°以上 OVER	±0.5					仕上げ FINISH	—	REVISE ONLY ON CAD SYSTEM
10°以上 30°未滿 UNDER	±0.25	A	変更 REVISION (J2004-2697)	Y.S.	04/2/23	適用電線範囲 WIRE RANGE	—	TITLE 名称
未滿 10° UNDER	±0.2	0	新規作成 (J2004-1513)	Y.U.	03/12/12	被覆外径 INS. RANGE	—	0.5 FPC Conn ZIF SMT RA Bottom Contact Embstp Pkg -LEAD FREE-
一般公差 GENERAL TOLERANCES	記号 LTR	変更内容 REVISION RECORD	DR. CHK.	日付 DATE	APP'D BY M.SASAO	尺度 SCALE	—	DWG.NO. (SHEET 1 OF 3) REV SD-52746-***70 A

SD-52746-\*\*\*70.S01



DWG. NO.  
SD-52746-\*\*-70

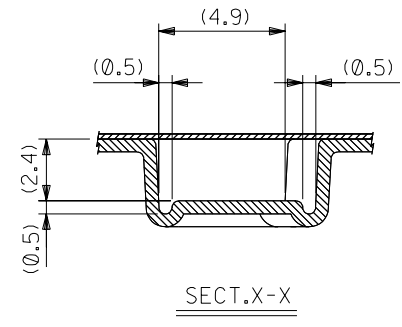
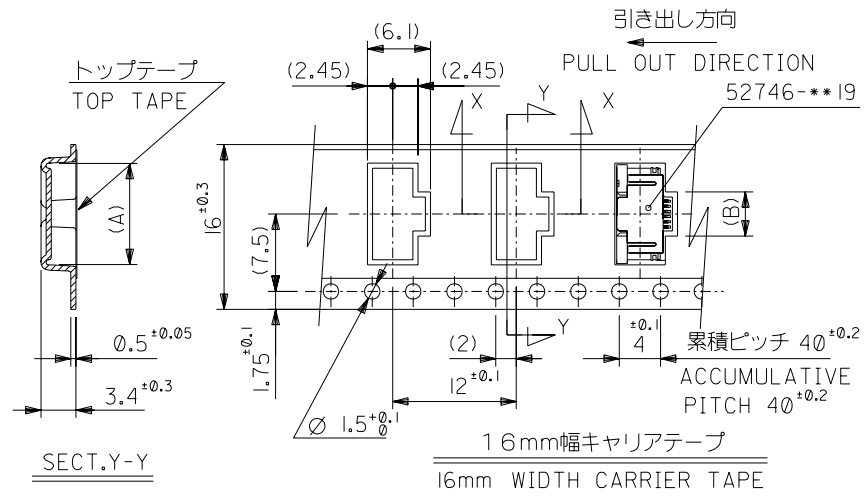

16mm幅キャリアテープ  
16mm WIDTH CARRIER TAPE

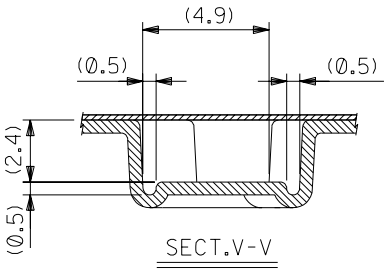
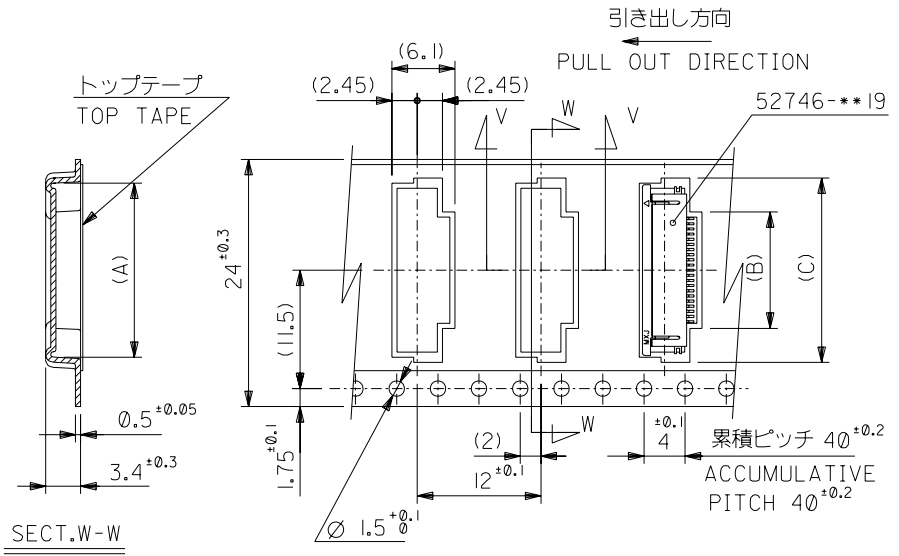

24mm幅キャリアテープ  
24mm WIDTH CARRIER TAPE

24	29.4	25.4	18.4	11.8	17.4	52746-2270	22
			17.9	11.3	16.9	-2170	21
			17.4	10.8	16.4	-2070	20
			16.9	10.3	15.9	-1970	19
			16.4	9.8	15.4	-1870	18
			15.9	9.3	14.9	-1770	17
			15.4	8.8	14.4	-1670	16
			14.9	8.3	13.9	-1570	15
			14.4	7.8	13.4	-1470	14
			13.9	7.3	12.9	-1370	13
			13.4	6.8	12.4	-1270	12
			12.9	6.3	11.9	-1170	11
			12.4	5.8	11.4	-1070	10
			11.9	5.3	10.9	-0970	9
11.4	4.8	10.4	-0870	8			
10.9	4.3	9.9	-0770	7			
10.4	3.8	9.4	-0670	6			
16	21.4	17.4	2.8	8.4	52746-0470	4	
キャリアテープ幅 CARRIER TAPE WIDTH	E	D	(C)	(B)	(A)	MATERIAL NO.	極数 CIRCUITS

角度 ANGLE	±30				
30以上 OVER	+0.5				
10以上 30未満 UNDER	+0.25	A	変更 REVIS (J2004-2697)	Y.S.	04/2/23
未滿 10 UNDER	+0.2	0	新規作成 (J2004-1513)	M.S.	03/12/12
一般公差 GENERAL TOLERANCES		記号 LTR	変更内容 REVISION RECORD	DR. CHK.	日付 DATE

材料 MATERIAL	
SHEET 1 OF 3 参照 REFER TO SHEET 1 OF 3	
仕上げ FINISH	—
適用電線範囲 WIRE RANGE	—
被覆外径 INS. RANGE	—
DRAWN BY '03/12/12 T.JENO	CHK'D BY '03/12/12 M.SASAO
APP'D BY '03/12/12 M.SASAO	尺度 SCALE —

**molex** MOLEX-JAPAN CO.,LTD.  
日本モレックス株式会社

REVISE ONLY ON CAD SYSTEM

TITLE 名称  
0.5 FPC Conn ZIF SMT RA  
Bottom Contact  
Embstp Pkg -LEAD FREE-

DWG.NO.(SHEET 2 OF 3) REV  
SD-52746-\*\*-70 A

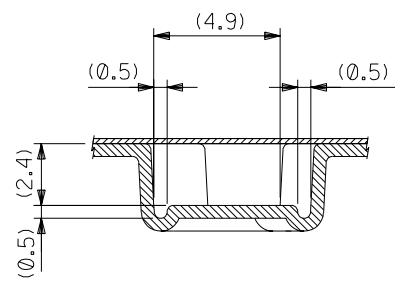
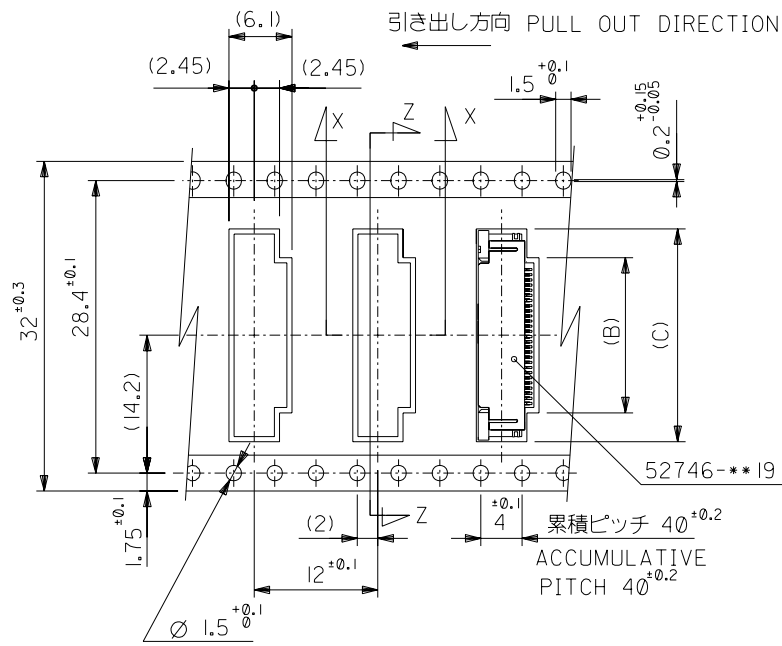
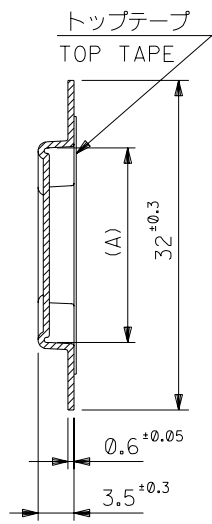

32mm幅キャリアテープ  
32mm WIDTH CARRIER TAPE

32	37.4	33.4	22.4	15.8	21.4	52746-3070	30
			21.9	15.3	20.9	-2970	29
			21.4	14.8	20.4	-2870	28
			20.9	14.3	19.9	-2770	27
			20.4	13.8	19.4	-2670	26
			19.9	13.3	18.9	-2570	25
			19.4	12.8	18.4	-2470	24
			18.9	12.3	17.9	52746-2370	23
キャリアテープ幅 CARRIER TAPE WIDTH	E	D	(C)	(B)	(A)	MATERIAL NO.	極数 CIRCUITS

角度 ANGLE		±30°				材料 MATERIAL	SHEET 1 OF 3 参照 REFER TO SHEET 1 OF 3		molex MOLEX-JAPAN CO.,LTD. 日本モレックス株式会社	
30°以上 OVER		+0.5				仕上げ FINISH	—			REVISE ONLY ON CAD SYSTEM
10°以上 OVER 30° UNDER		+0.25	A	変更 REVISD (J2004-2697)	Y.S.M.	適用電線範囲 WIRE RANGE	—		TITLE 名称	
未満 UNDER		+0.2	0	新規/作成 RELEASED (J2004-1513)	Y.U.M.	被覆外径 INS. RANGE	—		0.5 FPC Conn ZIF SMT RA Bottom Contact Embstp Pkg -LEAD FREE-	
一般公差 GENERAL TOLERANCES			記号 LTR	変更内容 REVISION RECORD	DR. CHK.	DATE	日付 DATE	APP'D BY '03/12/12 M.SASAO	尺度 SCALE	—
								DRAWN BY '03/12/12 T.UENO	CHK'D BY '03/12/12 M.SASAO	DWG.NO. (SHEET 3 OF 3) REV A

DWG. NO. SD-52746-\*\*-90

DIMENSIONS IN METRIC DO NOT SCALE DRAWING

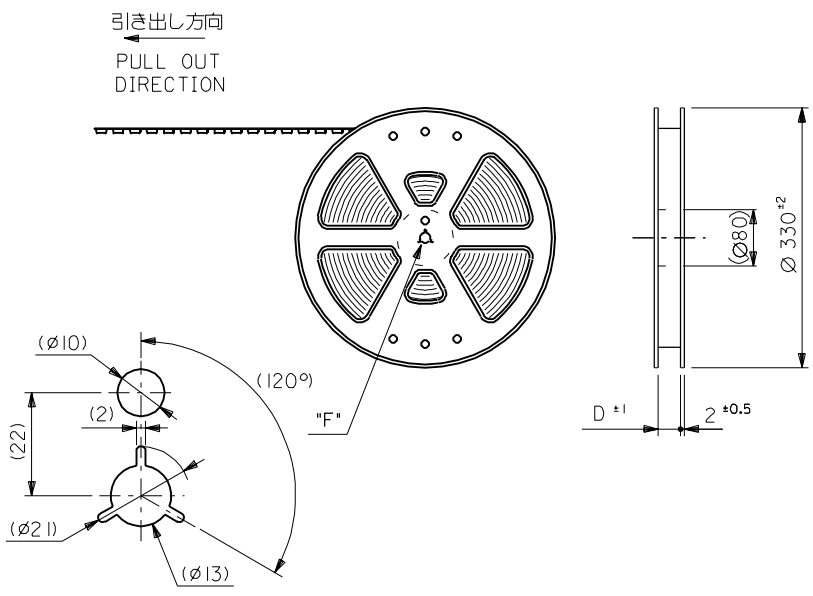

DETAIL "F"

5. 材料  
 キャリアテープ: ポリプロピレン (PP)  
 トップテープ: PET, PE, PEF  
 リール: ポリスチレン (PS) <リサイクル材を含む>  
 MATERIAL CARRIER TAPE: POLYPROPYLENE  
 TOP TAPE: PET, PE, PEF  
 REEL: POLYSTYRENE (PS)  
 <RECYCLE MATERIAL CONTAINED>

注記 NOTES

1. 製品番号 52746-\*\*-17 の梱包状態はアクチュエータがロックした状態とする。  
 詳細寸法については図面 SD-52746-\*\*-17 を参照下さい。  
 IN THE PACKAGE, ACTUATOR OF PART NO. 52746-\*\*-17 SHOULD BE LOCKED  
 RE DETAILED DIMENSIONS, SEE SD-52746-\*\*-17

2. 梱包数量: 1000個/リール  
 NUMBER OF CONNECTORS: 1000PCS/REEL

3. リードテープ長さ LEAD TAPE LENGTH

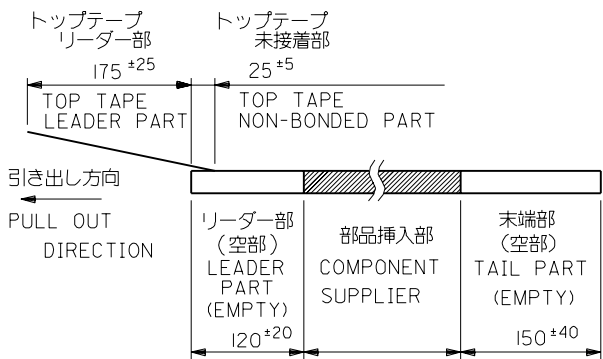

4. トップテープの剥離強度: (剥離方向は下図参照)

0.1N~0.7N (10.2gf~71.4gf) 尚、本規格値は、出荷時に適用。  
 (但し、輸送時に剥離が発生しない事。)

PEELING OFF FORCE OF TOP TAPE

0.1N~0.7N (10.2gf~71.4gf) (PEELING DIRECTION AS SHOWN IN FOLLOWING FIG.)  
 THIS REQUIREMENT SHOULD BE APPLIED AT SHIPMENT

PEEL OFF SHOULD NOT BE ALLOWED,  
 DURING TRANSPORTATION

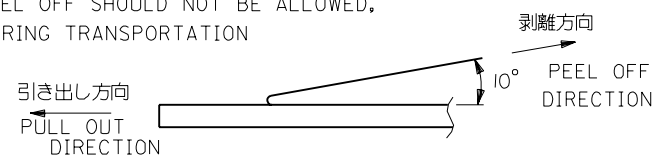

角度 ANGLE	30° 以上	30° 未満	10° 未満	10° 未満	一般公差 GENERAL TOLERANCES	変更 REVISION RECORD	記号 LTR	変更内容	DR. CHR.	日付 DATE	材料 MATERIAL	注記参照 SEE NOTES	MOLEX JAPAN CO., LTD. 日本モレックス株式会社
30° 以上 OVER	+0.3	30° 未満 UNDER	+0.25	10° 未満 UNDER	+0.2	B 変更 REVISION (JC2001-0425)	変	変更 (J40949)	変	94/12/20	仕上げ FINISH	—	REVISE ONLY ON CAD SYSTEM
適用電線範囲 WIRE RANGE	—	適用電線範囲 WIRE RANGE	—	適用電線範囲 WIRE RANGE	—	A 変更 REVISION (J40949)	変	新規作成 (J40230)	変	94/11/17	適用電線範囲 WIRE RANGE	—	TITLE 名称
被覆外径 INS. RANGE	—	被覆外径 INS. RANGE	—	被覆外径 INS. RANGE	—	O 新規作成 (J40230)	変	—	変	94/3/24	被覆外径 INS. RANGE	—	0.5 FPC Conn ZIF SMT RA Bottom Contact Embstp Pkg
DRAWN BY	94/3/24	CHK'D BY	94/12/20	DRAWN BY	94/12/20	—	—	—	—	—	—	—	DWG. NO. (SHEET 1 OF 3)
APP'D BY	94/12/20	—	—	APP'D BY	94/12/20	—	—	—	—	—	—	—	SD-52746-**-90
—	—	—	—	—	—	—	—	—	—	—	—	—	REV B

THIS DRAWING CONTAINS INFORMATION THAT IS PROPRIETARY TO MOLEX(JAPAN) AND SHOULD NOT BE USED WITHOUT WRITTEN PERMISSION  
 本図面は日本モレックス(株)の所有する情報を含むもので 当社の許可なく複製を禁止する。  
 EN-OIC(032)MXJ-32

DWG. NO.  
SD-52746-\*\*-90

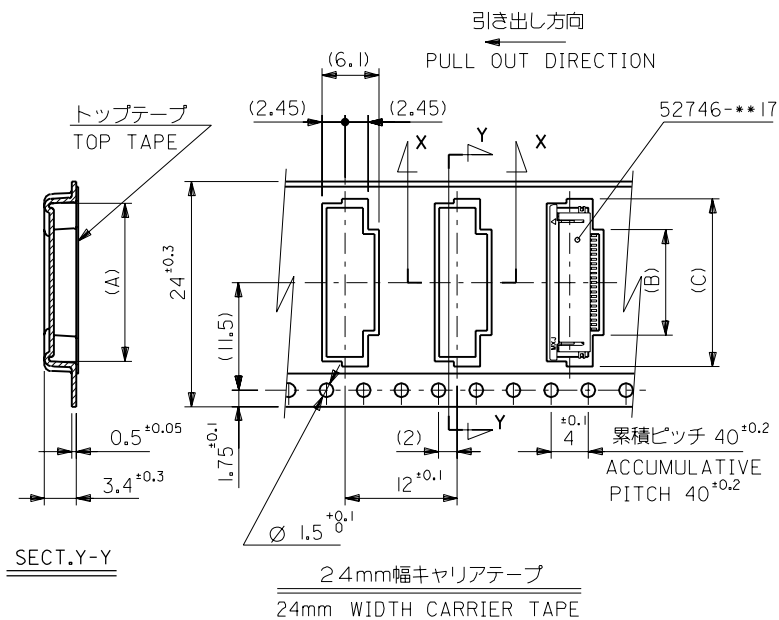

SECT. Y-Y

24mm幅キャリアテープ  
24mm WIDTH CARRIER TAPE

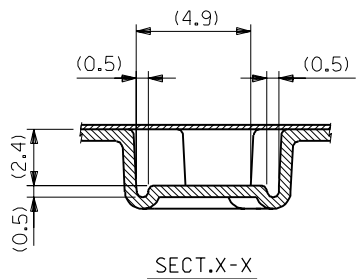

SECT. X-X

角度 ANGLE	±3°
30°以上	+0.3
10°以上 30°未満	+0.25
10°未満	+0.2
一般公差 GENERAL TOLERANCES	

変更 REVISED	UC2001-0425	Y.K.	00/12/20
変更 REVISED	(J40949)	T.M.	94/11/17
新規作成 RELEASED	(J40230)	S.S.	94/3/24
記号 LTR	変更内容 REVISION RECORD	DR. CHR.	日付 DATE

材料  
MATERIAL  
SHEET 1 OF 3 参照  
REFER TO SHEET 1 OF 3

仕上げ  
FINISH

適用電線範囲  
WIRE RANGE

被覆外径  
INS. RANGE

DRAWN BY '94/3/24  
S.AIHARA

CHK'D BY '00/12/20  
S.KUNISHI

APP'D BY '00/12/20  
M.FUKUSHIMA

尺度  
SCALE

**molex** MOLEX-JAPAN CO.,LTD.  
日本モレックス株式会社

REVISION ON CAD SYSTEM

TITLE 名称  
0.5 FPC Conn ZIF SMT RA  
Bottom Contact  
Embstp Pkg

DWG. NO. (SHEET 2 OF 3) REV  
SD-52746-\*\*-90 B

24	25.5	17.4	10.8	16.4	52746-2090	20
		16.9	10.3	15.9	-1990	19
		16.4	9.8	15.4	-1890	18
		15.9	9.3	14.9	-1790	17
		15.4	8.8	14.4	-1690	16
		14.9	8.3	13.9	-1590	15
		14.4	7.8	13.4	-1490	14
		13.9	7.3	12.9	-1390	13
		13.4	6.8	12.4	-1290	12
		12.9	6.3	11.9	-1190	11
		12.4	5.8	11.4	-1090	10
		11.9	5.3	10.9	-0990	9
		11.4	4.8	10.4	-0890	8
10.9	4.3	9.9	-0790	7		
10.4	3.8	9.4	52746-0690	6		
キャリアテープ幅 CARRIER TAPE WIDTH		D	(C)	(B)	(A)	ENG. NO.
						極数 CIRCUIT

THIS DRAWING CONTAINS INFORMATION THAT IS PROPRIETARY TO MOLEX(JAPAN) AND SHOULD NOT BE USED WITHOUT WRITTEN PERMISSION  
本図面は日本モレックス(株)の所有する情報を含むもので 当社の許可なく複製を禁止する。  
EN-OIC(032)MXJ-32

DIMENSIONS IN METRIC DO NOT SCALE DRAWING

5274690G.S81

DWG. NO.  
SD-52746-\*\*-90

E

D

C  
B  
A  
DIMENSIONS IN METRIC DO NOT SCALE DRAWING

F

E

D

C

B

A

8 7 6 5 4 3 2 1

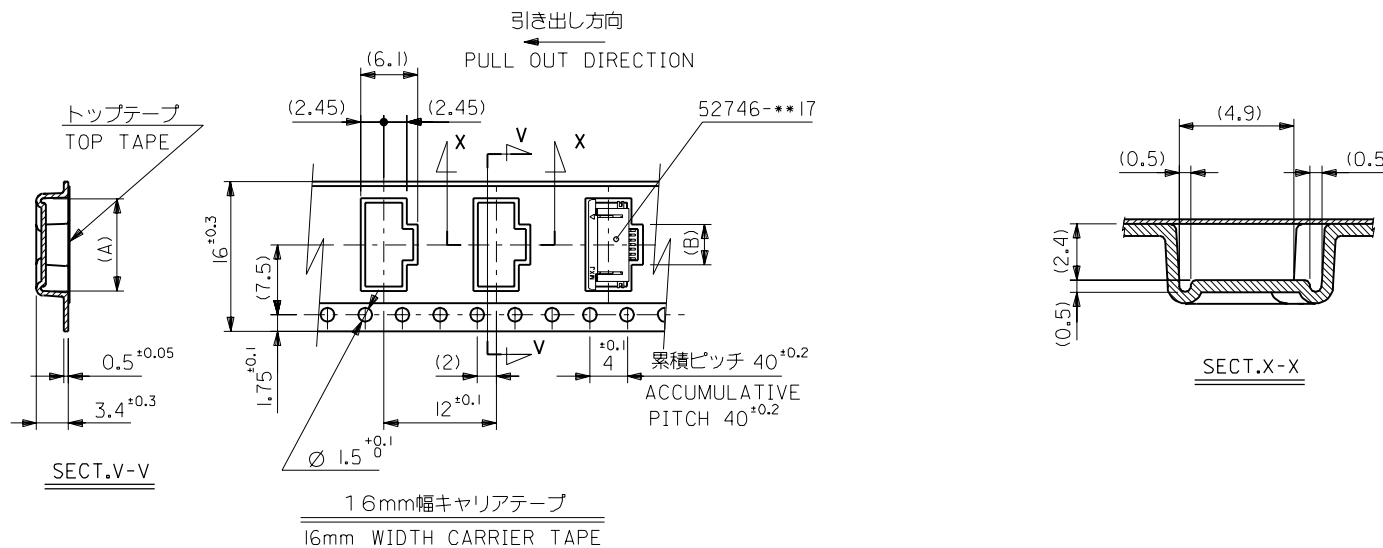

16	17.5	2.8	8.4	52746-0490	4
キャリアテープ幅 CARRIER TAPE WIDTH	D	(B)	(A)	ENG. NO.	極数 CIRCUIT

材料 MATERIAL	SHEET 1 OF 3 参照 REFER TO SHEET 1 OF 3		molex MOLEX-JAPAN CO.,LTD. 日本モレックス株式会社	
仕上げ FINISH	//		REVISE ONLY ON CAD SYSTEM	
適用電線範囲 WIRE RANGE	//		TITLE 名称	
被覆外径 INS. RANGE	//		0.5 FPC Conn ZIF SMT RA Bottom Contact Embstp Pkg	
DRAWN BY '94/3/24 S.AIHARA	CHK'D BY '00/12/20 S.KUNISHI	DWG. NO. (SHEET 3 OF 3) REV		
APP'D BY '00/12/20 M.FUKUSHIMA	尺度 SCALE	//		SD-52746-**-90 B
角度 ANGLE	±3°	変更 REVISED (JC2001-0425)	日付 DATE '00/12/20	
30°以上 OVER	+0.3	A 変更 REVISED (J40949)	日付 DATE '94/11/17	
10°以上 30°未満 UNDER	+0.25	O 新規作成 RELEASED (J40230)	日付 DATE '94/3/24	
10°未満 UNDER	+0.2	記号 LTR	変更内容 REVISION RECORD	
一般公差 GENERAL TOLERANCES		DR. CHR.	日付 DATE	

THIS DRAWING CONTAINS INFORMATION THAT IS PROPRIETARY TO MOLEX(JAPAN) AND SHOULD NOT BE USED WITHOUT WRITTEN PERMISSION  
本図面は日本モレックス(株)の所有する情報を含むもので 会社の許可なく複製を禁止する。  
EN-01C(032)MXJ-32

8 7 6 5 4 3 2 1