

HEATSINK SINK AND CLIP ARE OPTIONAL
SEE CHART FOR HEATSINK OPTIONS
CUSTOM HEATSINKS ARE AVAILABLE

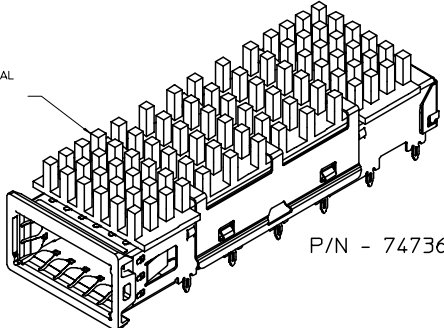

P/N - 747360212

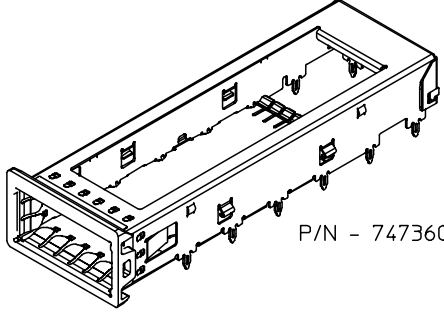

P/N - 747360210

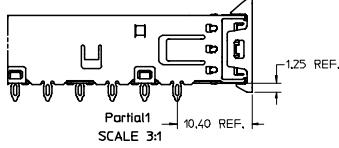
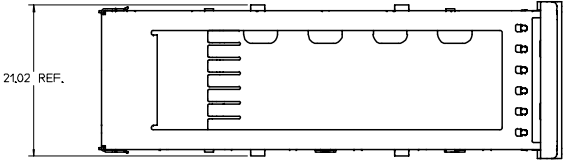

Partial
SCALE 3:1

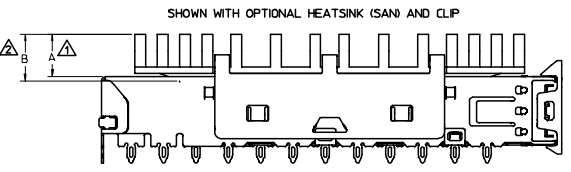
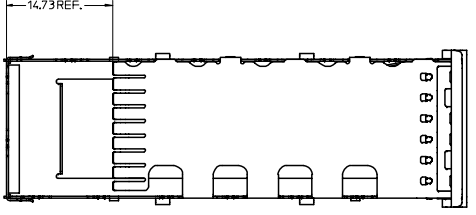
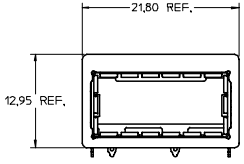
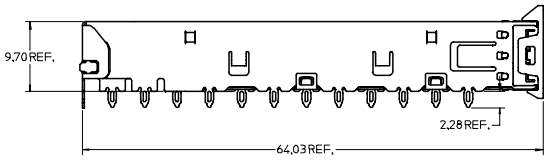

SHOWN WITH OPTIONAL HEATSINK (SAN) AND CLIP

- MAXIMUM HEIGHT OF HEATSINK WITH MODULE INSERTED
- OVERALL HEIGHT OF HEATSINK
- 3. OTHER HEATSINK DESIGNS ARE AVAILABLE INCLUDING CUSTOM DESIGNS

PART NUMBER FOR XFP CAGE ASSEMBLY & PARTS (W/OUT ELASTOMER EMI GASKET)					
P/N	DIM A	DIM B	DESCRIPTION	POWER LEVEL	THERMAL RESISTANCE @200 LFM
747360210	N/A	N/A	XFP CAGE WITH NO HEATSINK OR CLIP	N/A	N/A
747360211	4.0	4.2	XFP CAGE WITH PCI HEATSINK	UP TO 1.5W	<18.0 C/W
747360212	6.3	6.5	XFP CAGE WITH SAN HEATSINK (SHOWN)	UP TO 2.5W	<11.5 C/W
747360213	13.3	13.5	XFP CAGE WITH TALL HEATSINK	UP TO 3.5W	<8.0 C/W
747360230	N/A	N/A	HEATSINK CLIP ONLY	N/A	N/A
747360240	N/A	N/A	PCI HEATSINK ONLY	UP TO 1.5W	<18.0 C/W
747360241	N/A	N/A <td SAN HEATSINK ONLY	UP TO 2.5W	<11.5 C/W	
747360242	N/A	N/A	TALL HEATSINK ONLY	UP TO 3.5W	<8.0 C/W

EC NO: USY2005-0054 DRW:K.LLOYD 2004/12/06 CHK:D.BRUSSELL 2004/12/06 APPR:K.LLOYD 2004/12/07 REV A	QUALITY SYMBOLS	GENERAL TOLERANCES (UNLESS SPECIFIED)	SCALE 3:1	DESIGN UNITS METRIC	THIRD ANGLE PROJECTION	REVISE ON CAD ONLY	
	0.1 0.2	mm	INCH	DIMENSION STYLE MM ONLY		TITLE XFP CAGE ASSEMBLY WITHOUT ELASTOMER EMI GASKET DRAWN BY K.LLOYD DATE 2004/12/02 CHECKED BY BRUSSELL DATE 2004/12/02 APPROVED BY BRUSSELL DATE 2004/12/02	Molex MOLEX INCORPORATED MATERIAL NO. SEE CHART DOCUMENT NO. SD-74736-210 SHEET NO. 1 OF 2
		ANGULAR ± 1°		DRAFT WHERE APPLICABLE MUST REMAIN WITHIN DIMENSIONS			
	THIS DRAWING CONTAINS INFORMATION THAT IS PROPRIETARY TO MOLEX INCORPORATED AND SHOULD NOT BE USED WITHOUT WRITTEN PERMISSION						

20 19 18 17 16 15 14 13 12 11 74736 9 8 7 6 5 4 3 2 1

L
K
J
I
H
G
F
E
D
C
B
A

L
K
J
I
H
G
F
E
D
C
B
A

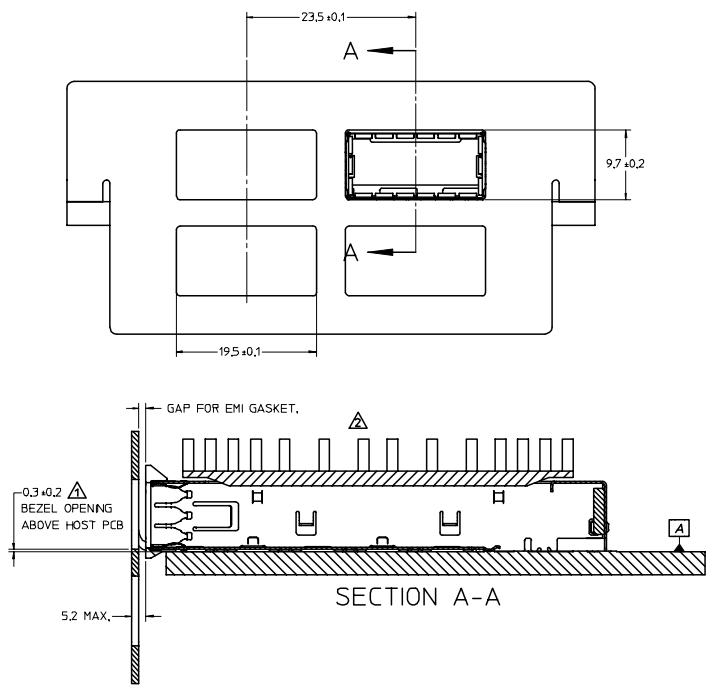
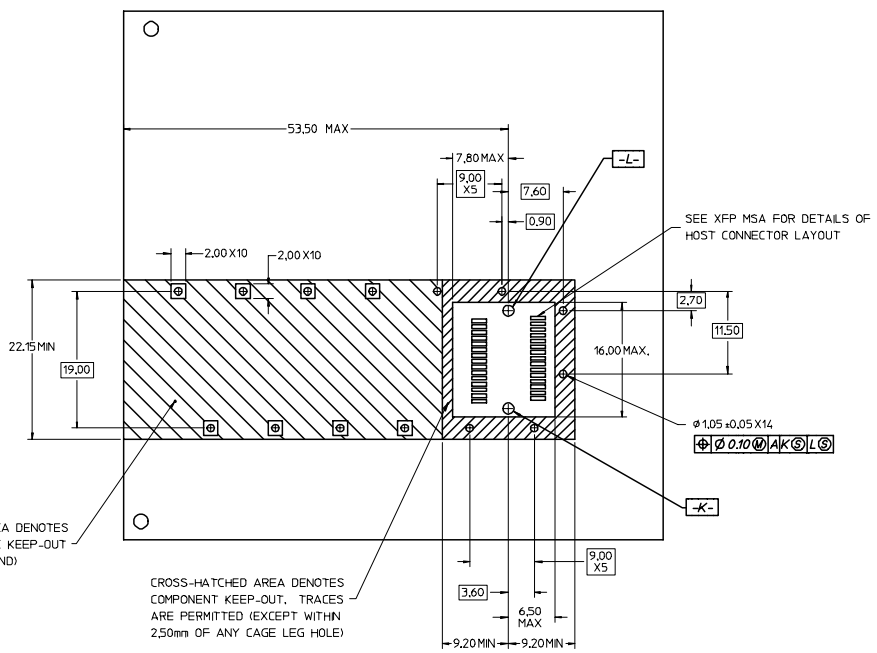

CROSS-HATCHED AREA DENOTES COMPONENT AND TRACE KEEP-OUT (EXCEPT CHASSIS GROUND)

CROSS-HATCHED AREA DENOTES COMPONENT KEEP-OUT. TRACES ARE PERMITTED (EXCEPT WITHIN 2.50mm OF ANY CAGE LEG HOLE)

FOR PCI APPLICATIONS RECOMMENDED DIMENSION IS 0.4 ±0.1
 FLAT ROCK TOOLING CAN BE USED TO PRESS CAGE IN WITH OR WITHOUT HEATSINK
 BOTTOM OF PCB SHOULD BE PROPERLY SUPPORTED
 INSERTION FORCE MAX: 100LBS (WITH ANY PCB PLATING)

EC NO: USY2005-0054 DRWN: KLOYD 2004/12/06 CHKD: BRUSSELL 2004/12/06 APPR: KLOYD 2004/12/07 REV A	QUALITY SYMBOLS	GENERAL TOLERANCES (UNLESS SPECIFIED)	SCALE 3:1	DESIGN UNITS METRIC	THIRD ANGLE PROJECTION	REVISE ON CAD ONLY
	▽-0	mm INCH 4 PLACES ±--- ±--- 3 PLACES ±--- ±--- 2 PLACES ±0.10 ±--- 1 PLACE ±--- ±---	DIMENSION STYLE MM ONLY DRAWN BY DATE KLOYD 2004/12/02 CHECKED BY DATE BRUSSELL 2004/12/02 APPROVED BY DATE BRUSSELL 2004/12/02	TITLE	XFP CAGE ASSEMBLY WITHOUT ELASTOMER EMI GASKET	
	∇-0	ANGULAR ± 1°	DRAFT WHERE APPLICABLE MUST REMAIN WITHIN DIMENSIONS	MATERIAL NO.	DOCUMENT NO.	SHEET NO.
			THIS DRAWING CONTAINS INFORMATION THAT IS PROPRIETARY TO MOLEX INCORPORATED AND SHOULD NOT BE USED WITHOUT WRITTEN PERMISSION		SEE CHART	SD-74736-210

19 18 17 16 15 14 13 12 11 10 9 8 7 6 5 4 3 2 1

20 | 19 | 18 | 17 | 16 | 15 | 14 | 13 | 12 | 11 | 74736 | 9 | 8 | 7 | 6 | 5 | 4 | 3 | 2 | 1

L
K
J
I
H
G
F
E
D
C
B
A

L
K
J
I
H
G
F
E
D
C
B
A

HEATSINK SINK AND CLP ARE OPTIONAL
SEE CHART FOR HEATSINK OPTIONS
CUSTOM HEATSINKS ARE AVAILABLE

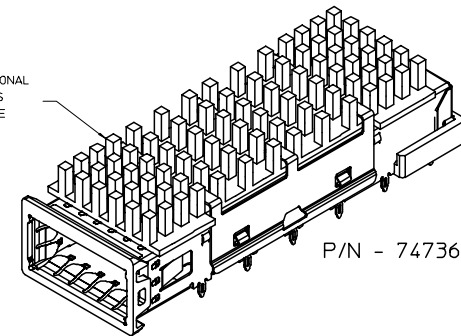

P/N - 747360222

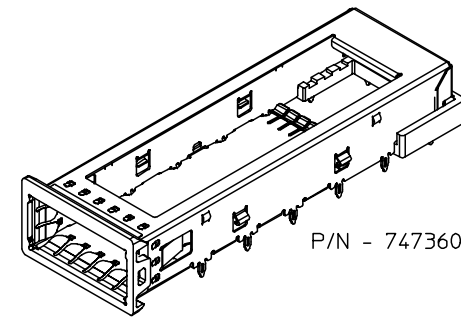

P/N - 747360220

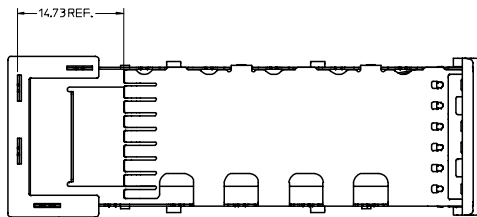
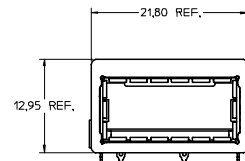
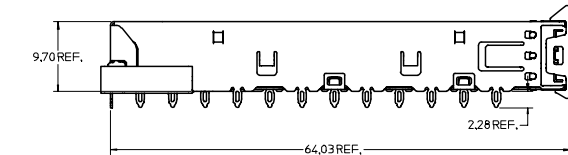
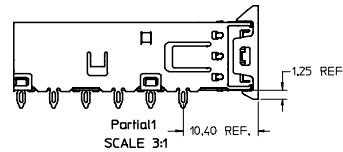
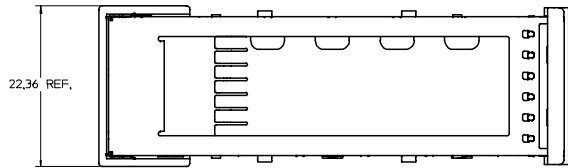

COMPLIANT EMI GASKET

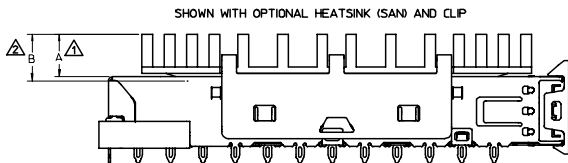

SHOWN WITH OPTIONAL HEATSINK (SAN) AND CLIP

- ▲ MAXIMUM HEIGHT OF HEATSINK WITH MODULE INSERTED
- ▲ OVERALL HEIGHT OF HEATSINK
- 3. OTHER HEATSINK DESIGNS ARE AVAILABLE INCLUDING CUSTOM DESIGNS

PART NUMBER FOR XFP CAGE ASSEMBLY & PARTS

P/N	DIM A	DIM B	DESCRIPTION	POWER LEVEL	THERMAL RESISTANCE @200 LFM
747360220	N/A	N/A	XFP CAGE WITH NO HEATSINK OR CLIP	N/A	N/A
747360221	4.0	4.2	XFP CAGE WITH PCI HEATSINK	UP TO 1.5W	<18.0 C/W
747360222	6.3	6.5	XFP CAGE WITH SAN HEATSINK (SHOWN)	UP TO 2.5W	<11.5 C/W
747360223	13.3	13.5	XFP CAGE WITH TALL HEATSINK	UP TO 3.5W	<8.0 C/W
747360230	N/A	N/A	HEATSINK CLIP ONLY	N/A	N/A
747360240	N/A	N/A	PCI HEATSINK ONLY	UP TO 1.5W	<18.0 C/W
747360241	N/A	N/A	SAN HEATSINK ONLY	UP TO 2.5W	<11.5 C/W
747360242	N/A	N/A	TALL HEATSINK ONLY	UP TO 3.5W	<8.0 C/W

EC NO: USY2005-0054 DRWN: KKLLOYD 2004/12/06 CHKD: BRUSSELL 2004/12/06 APPR: KKLLOYD 2004/12/07 REV:	QUALITY SYMBOLS	GENERAL TOLERANCES (UNLESS SPECIFIED)	SCALE 3:1	DESIGN UNITS METRIC	THIRD ANGLE PROJECTION	REVISE ON CAD ONLY
	-0.1 -0.2	mm	INCH	DIMENSION STYLE MM ONLY		TITLE XFP CAGE ASSEMBLY DRAWN BY KKLLOYD DATE 2004/05/14 CHECKED BY BRUSSELL DATE 2004/08/05 APPROVED BY BRUSSELL DATE 2004/08/05
		4 PLACES ±---	±---	MATERIAL NO. SEE CHART		
		3 PLACES ±---	±---	DOCUMENT NO. SD-74736-220		SHEET NO. 1 OF 2
	2 PLACES ±0.10	±---	MUST REMAIN WITHIN DIMENSIONS		THIS DRAWING CONTAINS INFORMATION THAT IS PROPRIETARY TO MOLEX INCORPORATED AND SHOULD NOT BE USED WITHOUT WRITTEN PERMISSION	

19 | 18 | 17 | 16 | 15 | 14 | 13 | 12 | 11 | 10 | 9 | 8 | 7 | 6 | 5 | 4 | 3 | 2 | 1

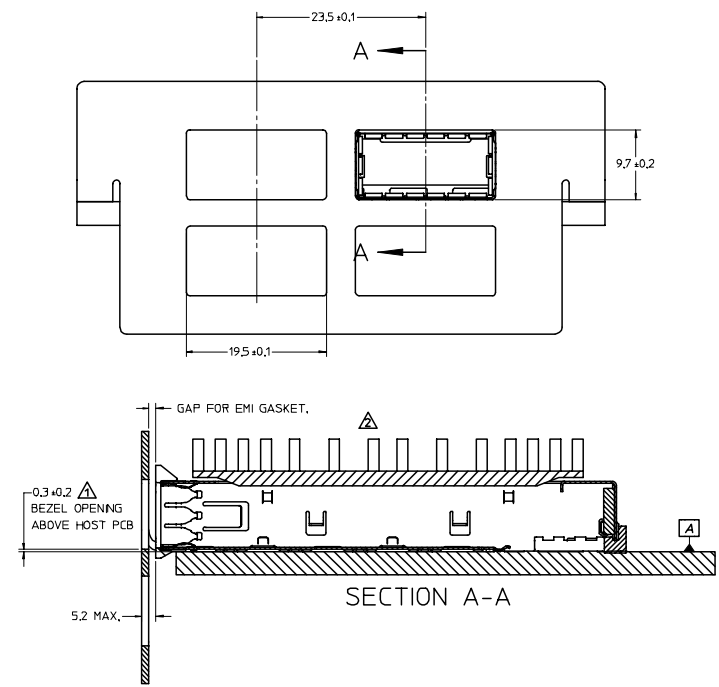
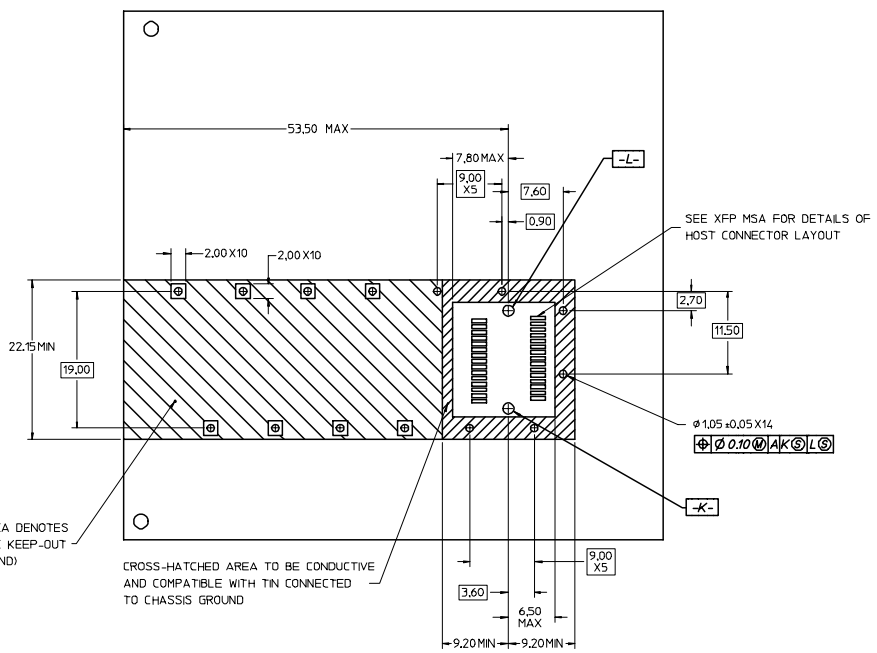

▲ FOR PCI APPLICATIONS RECOMMENDED DIMENSION IS 0.4 ±0.1
 ▲ FLAT ROCK TOOLING CAN BE USED TO PRESS CAGE IN WITH OR WITHOUT HEATSINK
 BOTTOM OF PCB SHOULD BE PROPERLY SUPPORTED
 INSERTION FORCE MAX: 100LBS (WITH ANY PCB PLATING)

EC NO: USY2005-0054 DRWN: KLOYD 2004/12/06 CHKD: BRUSSELL 2004/12/06 APPR: KLOYD 2004/12/07 REV DESCRIPTION	QUALITY SYMBOLS	GENERAL TOLERANCES (UNLESS SPECIFIED)	SCALE 3:1	DESIGN UNITS METRIC	THIRD ANGLE PROJECTION	REVISE ON CAD ONLY
	▽ -0	4 PLACES ± --- ± --- 3 PLACES ± --- ± --- 2 PLACES ± 0.10 ± --- 1 PLACE ± --- ± ---	mm INCH	DIMENSION STYLE MM ONLY	TITLE XFP CAGE ASSEMBLY	
	∇ -0	ANGULAR ± 1 °	DRAWN BY KLOYD	DATE 2004/05/14	MATERIAL NO. DOCUMENT NO. SHEET NO.	
		DRAFT WHERE APPLICABLE MUST REMAIN WITHIN DIMENSIONS	CHECKED BY BRUSSELL	DATE 2004/08/05	MATERIAL NO. SD-74736-220	
		APPROVED BY BRUSSELL		DATE 2004/08/05	MATERIAL NO. SD-74736-220	
THIS DRAWING CONTAINS INFORMATION THAT IS PROPRIETARY TO MOLEX INCORPORATED AND SHOULD NOT BE USED WITHOUT WRITTEN PERMISSION						